

SCHNEEBERGER

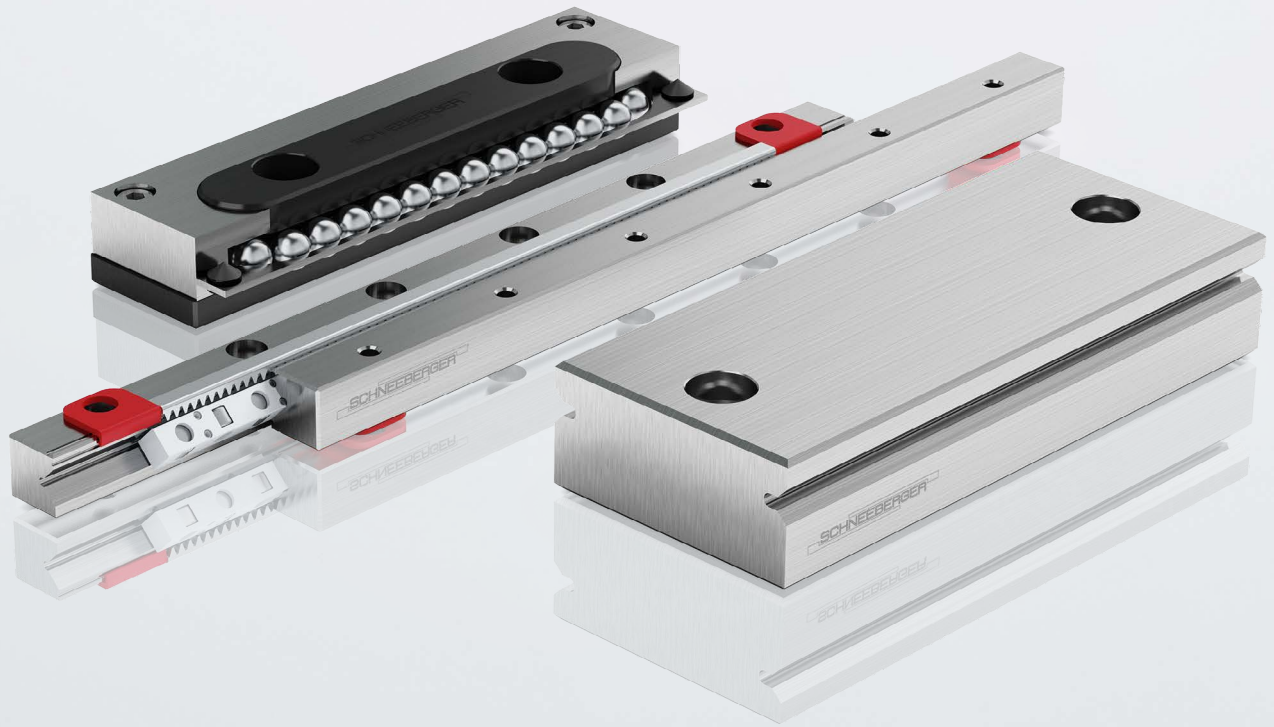

LINEAR BEARINGS

and Recirculating Units

Product catalog

| | | |
|----------|---|-----------|
| 1 | Foreword | 3 |
| 2 | Useful guidelines | 4 |
| 2.1 | 2D- and 3D-drawings | 4 |
| 2.2 | Regulations governing substances and limit values | 4 |
| 2.3 | Index and type designations | 5 |
| 2.4 | Description of the units | 9 |
| 3 | Overview of product | 10 |
| 3.1 | An overview of linear guideways | 11 |
| 3.2 | An overview of recirculating units | 13 |
| 3.3 | Earlier generations of the product | 14 |
| 3.4 | Slideways | 15 |
| 3.5 | Application-specific solutions | 15 |
| 4 | Applications | 17 |
| 5 | Product specifications | 21 |
| 5.1 | Type R and RD | 21 |
| 5.2 | Type RN | 31 |
| 5.3 | Type RNG | 37 |
| 5.4 | Type N/O | 45 |
| 5.5 | Type M/V | 53 |
| 6 | Recirculating unit | 61 |
| 6.1 | Type SK and SKD | 62 |
| 6.2 | Type SKC | 65 |
| 6.3 | Type SR | 68 |
| 6.4 | Type NRT (with NRV) | 71 |
| 7 | Options for linear guideways | 75 |
| 7.1 | Quality classes (SQ and SSQ) | 75 |
| 7.2 | Guideways made of corrosion-resistant steel (RF) | 75 |
| 7.3 | Run-ins rounded (EG) | 76 |
| 7.4 | Multi-part linear guideways (ZG) | 76 |
| 7.5 | Height-matched guideways (HA and EHA) | 77 |
| 7.6 | DURALLOY® coating (DU) | 77 |
| 7.7 | DryRunner coating (DR and DRC1) | 78 |
| 7.8 | Cage control FORMULA-S (KS) | 79 |
| 7.9 | Cage control for N/O and M/V guideways (KZST) | 80 |
| 7.10 | Fixing Hole Variants (V, G, or D) | 80 |

| | | |
|-----------|--|------------|
| 8 | Recirculating unit options | 85 |
| 8.1 | Matched recirculating units (GP) | 85 |
| 8.2 | Centralised lubricating system (ZS) for recirculating units NRT | 86 |
| 9 | Linear guideways standard parameters | 87 |
| 9.1 | Tolerance of the supporting surface to the track | 87 |
| 9.2 | Length tolerances and distances between fixing holes | 88 |
| 9.3 | Operating temperatures | 88 |
| 9.4 | Speeds and accelerations | 88 |
| 9.5 | Friction, running accuracy and smoothness | 88 |
| 10 | Recirculating unit standard parameters | 89 |
| 10.1 | Operating temperatures | 89 |
| 10.2 | Speeds and accelerations | 89 |
| 10.3 | Friction, running accuracy and smoothness | 89 |
| 11 | Design | 90 |
| 11.1 | Linear guideways | 90 |
| 11.2 | Recirculating units | 94 |
| 12 | Load carrying capacity and service life | 95 |
| 12.1 | Basic principles | 95 |
| 12.2 | Short strokes | 96 |
| 12.3 | Calculating the service life L in accordance with the DIN ISO standard | 97 |
| 12.4 | Example calculations | 102 |
| 12.5 | Elastic deformation and rigidity of linear bearings | 111 |
| 12.6 | Elastic deformation and rigidity of recirculating units | 113 |
| 13 | Construction and installation guidelines | 117 |
| 13.1 | The connecting structure and its influence on service life | 117 |
| 13.2 | Configuration of the connecting structure | 117 |
| 13.3 | Installation methods | 120 |
| 13.4 | Fastening | 124 |
| 13.5 | Torque settings for fastening screws | 125 |
| 13.6 | Preload | 126 |
| 13.7 | Sealing and covers | 132 |
| 13.8 | Lubrication | 133 |
| 13.9 | Transport, handling and storage | 135 |
| 13.10 | Installation guidelines | 135 |
| 14 | Order descriptions | 139 |

In 1923 SCHNEEBERGER laid the foundation of what is today global linear motion technology. SCHNEEBERGER standards then made it possible to build linear guideways, which in terms of loading capacity, reliability and cost-effectiveness set new standards and soon defined what is today the definitive industry standard.

The same principles that were the foundation for our success, informing our way of thinking and acting apply today as previously: the spirit of innovation, a no-compromise approach to quality and the ambition to deliver to our customers products that are technically and economically superior again and again. Both then and today the name SCHNEEBERGER throughout the world is synonymous with modern linear guide technology. Our core competencies, development, production and application know-how make us a well respected business partner. Together with our committed, customer-oriented and unique employees, we are global leaders.

We have developed a broad and deep expert knowledge from many successful projects in a variety of industries. Together with customers we evaluate the best products from the standard range or define project-specific solutions. Thanks to many years of experience and consistent focus on linear motion technology, we have been able to continuously develop our products and solutions and so provide our customers with technical advantages.

State-of-the-art production technologies and highly specialised employees are responsible for the highest possible quality standards. Our production is subject to stringent specifications and tests.

Our high-precision products are suitable for use in a variety of fields of application:

- Biotechnology
- Semiconductor industry
- Laboratory automation
- Medical technology
- Pick and place machines
- Measuring technology
- Micro-automation
- Nanotechnology
- Surface finishing
- Optics industry
- Processing machines for the micro-sector

Our linear guideways and recirculating units are available in many designs, sizes and standard lengths and depending on the specific application can be equipped with balls, rollers or needles.

The use of SCHNEEBERGER linear guideways and recirculating units makes it possible to build cost-effective linear guideway systems. The strengths of our products:

- High level of smoothness and consistent accuracy
- No stick-slip effect
- Rapid travelling speeds
- Minimal wear
- High level of reliability
- High rigidity
- High load carrying capacity
- Used in vacuum and clean room

Our skilled and committed employees will be pleased to advise you at any time on how to develop your applications.

2 Useful guidelines

2.1 2D- and 3D-drawings

Drawings and models are available on the Cadenas Part Server free of charge in all formats.

The required download area with additional product information can be found on the web site www.schneeberger.com.

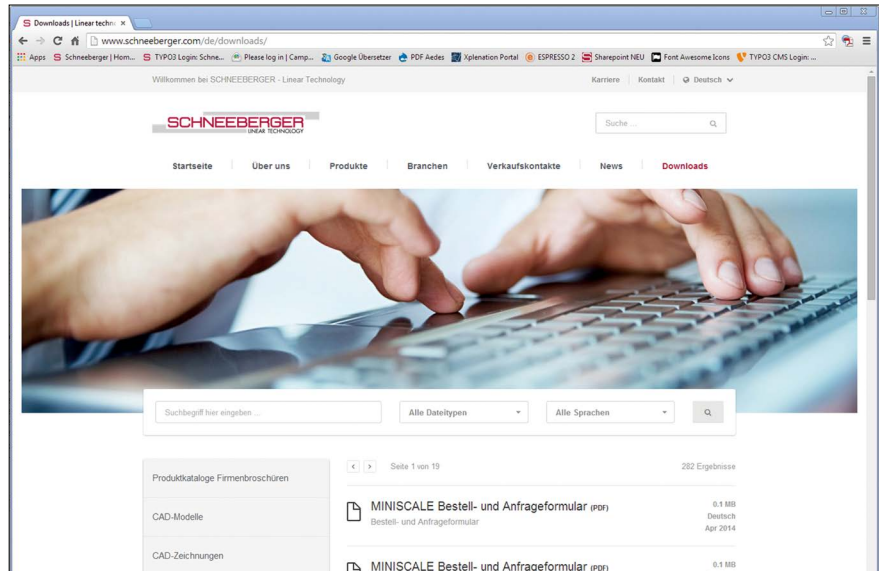

Our website www.schneeberger.com

2.2 Regulations governing substances and limit values

The products presented in this catalogue do not include any forbidden substances based on the RoHs guidelines and do not release chemical substances in accordance with the REACH guidelines.

2 Useful guidelines

2.3 Index and type designations

| A | Chapter |
|------------------------------------|-----------------------|
| A rail | 3.3 |
| AA-RF | 5.1 |
| AC | 5.1 |
| Accelerations | 5 / 6 / 9.5 / 10.2 |
| Accuracy and accuracy classes | 7.1 / 9.2 |
| AK | 5.1 |
| Angular error | 13.2 |
| Application-specific solutions | 3.5 |
| Assembly guidelines | 13.9 |
| B | |
| B rail | 3.3 |
| C | |
| C rail | 3.3 |
| Cage | 5 |
| Cage length | 11.1 |
| Cage control | 5.2 / 5.3 / 7.8 / 7.9 |
| Centralised lubricating system | 8.2 / 13.7 |
| Chemical substances | 2.2 |
| Coating | 7.6 / 7.7 |
| Connecting structure | 13.1 / 13.2 |
| Cover | 13.6 |
| Correction factor | 12.3 |
| Corrosion-resistant steel | 7.2 |
| Customer-specific design | 3.5 |
| D | |
| Design | 11 |
| Design guidelines | 13 |
| D hole | 7.10 |
| D rail | 3.3 |
| Double V-shaped guide | 5.1 |
| DR | 7.7 |
| Drawings (2D and 3D) | 2.1 |
| DRC1 | 7.7 |
| Dry Runner | 7.7 |
| DU | 7.6 |
| DURALLOY® | 7.6 |
| Dynamically equivalent load | 12.3 |
| E | |
| EAM | 5.5 |
| Earlier generations of the product | 3.3 |
| EAV | 5.5 |
| EE | 5.1 |
| Effective load carrying capacity | 12.3 |
| EG | 7.3 |
| EHA | 7.5 |
| Elastic deformation | 12.5 |

| E | Chapter |
|----------------------------------|-----------------------|
| EM | 5.5 |
| Emergency running characteristic | 7.6 |
| Enclosed configuration | 13.3 |
| End pieces | 5 |
| End screws | 5 |
| E rail | 3.3 |
| EV | 5.5 |
| Event probability | 12.3 |
| Example calculations | 12.4 |
| Examples of use | 4 |
| F | |
| Fastening | 13.4 |
| Fastening screws with thin shaft | 5.1 / 5.2 / 5.3 / 5.4 |
| Fixing holes | 5 / 6 / 7.10 / 9.3 |
| FORMULA-S | 5.2 / 5.3 / 7.8 |
| Friction | 9.6 / 10.3 |
| G | |
| GA | 5.1 / 5.2 |
| GAN | 5.2 |
| GB | 5.1 |
| GBN | 5.3 |
| GC | 5.1 |
| GC-A | 5.1 |
| GCN | 5.3 |
| GCN-A | 5.3 |
| GD | 5.1 / 5.2 / 5.4 |
| GDN | 5.3 |
| GFN | 5.4 |
| GFO | 5.4 |
| GH | 5.4 |
| GH-A | 5.4 |
| G hole | 7.10 |
| GP | 8.1 |
| GW | 5.4 |
| GW-A | 5.4 |
| H / I / J | |
| HA | 7.5 |
| Handling | 13.8 |
| Hardness | 5 / 6 |
| Hardness factor | 12.3 |
| Height-matched linear guideways | 7.5 |
| Height offset | 13.2 |
| Hole types | 5 / 6 / 7.10 |
| Stroke | 11.1 |
| HW | 5.4 / 5.5 |
| Installation methods | 13.3 |
| Installation guidelines | 13 |
| J/K | 3.3 |

| K | Chapter |
|----------------------------------|--------------------|
| KBN | 5.2 / 5.3 |
| KBS | 5.2 / 5.3 |
| KS | 5.2 / 5.3 / 7.8 |
| KZST | 5.4 / 5.5 / 7.9 |
| L | |
| Linear guideways ground together | 7.4 |
| L/M | 3.3 |
| Load carrying capacity | 12 |
| Loading capacity | 5 / 6 / 12 |
| Locating surface | 7.1 / 13.1 / 13.2 |
| Lubrication | 12.2 / 13.7 |
| Lubricating stroke | 12.2 |
| M | |
| Matched recirculating units | 8.1 |
| Materials | 5 / 6 |
| Minimal lubrication | 7.7 |
| Multi-part linear guideways | 7.4 |
| Moment loads | 5 / 6 |
| M/V | 3.1 / 5.5 |
| N | |
| N/O | 3.1 / 5.4 |
| Normal quality | 7.1 |
| NQ | 7.1 |
| NRT | 3.2 / 6.4 |
| NRV | 3.2 / 6.4 |
| Number of rolling elements | 11.1 |
| O | |
| Open configuration | 13.3 |
| Operating temperatures | 5 / 6 / 9.4 / 10.1 |
| Options | 7 / 8 |
| Order descriptions | 14 |
| Oscillating motion | 12.2 |
| Overrunning cage | 5 / 11.1 |
| Overview of products | 3 |
| P / Q | |
| Parallelism tolerances | 7.1 |
| Part Server | 2.1 |
| Preload | 13.5 |
| Preload wedge | 6.4 |
| Product specifications | 5 / 6 |
| Product overview | 3 |
| Quality classes | 7.1 |
| R | |
| Ra value | 13.2 |
| RD | 3.1 / 5.1 |
| REACH | 2.2 |
| Recirculating unit | 3.2 / 6 / 11.2 |
| RF | 7.2 |
| Rigidity | 12.5 |

| R | Chapter |
|--|---|
| R linear guideway | 3.1 / 5.1 |
| RN | 3.1 / 5.2 |
| RNG | 3.1 / 5.3 |
| RoHS | 2.2 |
| Run-ins rounded | 7.3 |
| S | |
| Seal | 13.6 |
| Sealing rings | 13.7 |
| Service life | 12.1 / 12.2 / 12.3 / 13.1 |
| Short stroke | 12.2 |
| SHW | 5.4 / 5.5 |
| SK | 3.2 / 6.1 |
| SKC | 3.2 / 6.2 |
| SKD | 3.2 / 6.1 |
| Sliding guideway | 3.4 |
| Spacings between fixing holes | 9.3 |
| Speeds | 5 / 6 / 9.5 / 10.2 |
| Special versions | 7 / 8 |
| SQ | 7.1 |
| SR | 3.2 / 6.3 |
| SSQ | 7.1 |
| Standard parameter | 9 / 10 |
| Storage | 13.8 |
| Subsequent lubrication | 13.7 |
| Supporting surface | 7.1 / 9.2 / 13.2 |
| Surface quality | 13.2 |
| T | |
| Temperatures | 5 / 6 / 9.4 / 10.1 |
| Temperature factor | 12.3 |
| Tolerance of the supporting surface to the track | 9.2 |
| Torque settings for adjusting screws | 13.5 |
| Torque settings for fastening screws | 13.5 |
| Transport | 13.8 |
| U / V / W / X / Z | |
| Units | 2.4 |
| Vacuum suitability | 5.1 / 5.2 / 5.3 / 6.2 / 7.6 / 7.7 / 7.8 |
| V hole | 7.10 |
| Web site | 2.1 |
| Wipers | 5.1 / 5.3 / 5.4 / 5.5 / 6.1 / 6.2 / 6.4 |
| W/Z | 3.3 |
| ZG | 7.4 |
| ZS | 8.2 |

2 Useful guidelines

2.4 Description of the units

| Name | Description | Unit |
|--------------------------------------|---|--------|
| a | Event probability | Factor |
| C ₀ | Static loading capacity | N |
| C | Dynamic loading capacity for a 100'000 m travel distance C corresponds to C100 for SCHNEEBERGER products | N |
| C ₁₀₀ | Dynamic loading capacity for a 100'000 m travel distance | N |
| C ₅₀ | Dynamic loading capacity for a 50'000 m travel distance | N |
| C _{eff} | Effective load carrying capacity per rolling element | N |
| D _w | Diameter of the rolling element | mm |
| F | Operating load, load of the linear guideway | N |
| F _{1... F₂...} | Individual loads | N |
| f _h | Hardness factor | Factor |
| f _t | Temperature factor | Factor |
| H | Stroke | mm |
| K | Cage length | mm |
| K _t | Load-bearing (cage) length | mm |
| L | Length | mm |
| L | Nominal service life | m |
| L _{1 ... L₂ ...} | Partial travel distance | mm |
| M | Moment load longitudinally and laterally | Nm |
| M _{ds} | Tightening torque | Ncm |
| M _L | Permissible moment load longitudinally and laterally | Nm |
| M _Q | Permissible moment load transversely | Nm |
| P | Dynamically equivalent load | N |
| P _L | Dynamically equivalent load longitudinally | N |
| P _Q | Dynamically equivalent load transversely | N |
| P _{vs} | Infeed force | N |
| Q | Medium linear guideway distance | mm |
| R _A | Number of rolling elements | Item |
| R _T | Number of load-bearing rolling elements | Item |
| R _{Tmin} | Correction factor | Factor |
| t | Cage division | mm |
| t ₂ | Length of the middle section | mm |
| w | Distance Cage start to the middle of the first rolling element | mm |
| δ _S | Deformation of the connecting structure | µm |
| δ _A | Deformation of the rolling element including the guide rail | µm |

3 Overview of product



Linear guideway type R



Linear guideway type RD



Linear guideway type RN



Linear guideway type RNG



Linear guideway type N/O



Linear guideway type M/V



Recirculating unit type SK



Recirculating unit type SKD



Recirculating unit type SKC



Recirculating unit type SR



Recirculating unit type NRT

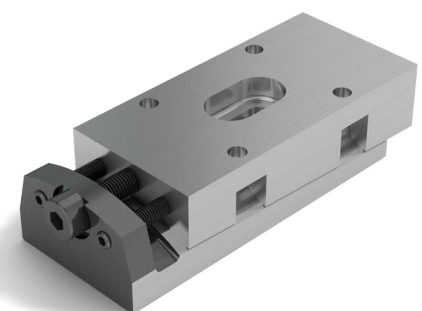

Preload wedge NRV

3 Overview of product

3.1 An overview of linear guideways

The SCHNEEBERGER range of linear guideways offers you perfect solutions for your specific applications.



| R | RD | RN | RNG | N/O | M/V |
|----|----|----|-----|-----|-----|
| 51 | 51 | 52 | 53 | 54 | 55 |

For features and dimension table, see chapter

Assessment of the advantages

Parameter: displacement force & high level of smoothness

| | | | | | | |
|-----------|------|------|-----|-----|-----|-----|
| - balls | ++++ | ++++ | n/a | n/a | n/a | n/a |
| - rollers | +++ | +++ | +++ | +++ | n/a | n/a |
| - needles | n/a | n/a | n/a | n/a | ++ | ++ |

Parameter: High loading capacity

| | | | | | | |
|-----------|-----|-----|-----|-----|------|------|
| - balls | + | + | n/a | n/a | n/a | n/a |
| - rollers | ++ | ++ | +++ | +++ | n/a | n/a |
| - needles | n/a | n/a | n/a | n/a | ++++ | ++++ |

Legend:

- ++++ best choice
- +++
- ++
- + good choice
- n/a not available

Performance parameters

| | | | | | | |
|--|-----------------|-----------------|-----------------|-----------------|-----------------|-----------------|
| Maximum acceleration in m/s ² | 50 | 50 | 50 | 50 | 50 | 50 |
| Maximum acceleration with cage control in m/s ² | n/a | n/a | 300 | 300 | 200 | 200 |
| Maximum speed in m/s | 1 | 1 | 1 | 1 | 1 | 1 |
| Maximum speed with cage control in m/s | n/a | n/a | 1 | 1 | 1 | 1 |
| Quality classes | see chapter 9.1 | see chapter 9.1 | see chapter 9.1 | see chapter 9.1 | see chapter 9.1 | see chapter 9.1 |
| Operating temperature in degrees Celsius | -40° C - +80° C | -40° C - +80° C | -40° C - +80° C | -40° C - +80° C | -40° C - +80° C | -40° C - +80° C |

Material (standard)

| | | | | | | |
|---|---------|---------|---------|---------|---------|---------|
| Rail made of tool steel, hardness in HRC | 58 - 62 | 58 - 62 | 58 - 62 | 58 - 62 | 58 - 62 | 58 - 62 |
| Rolling element made of tool steel, hardness in HRC | 58 - 64 | 58 - 64 | 58 - 64 | 58 - 64 | 58 - 64 | 58 - 64 |

Material (corrosion-resistant)

| | | | | | | |
|---|---------|---------|---------|---------|---------|---------|
| Rail made of tool steel, hardness in HRC | min. 54 | min. 54 | min. 54 | min. 54 | min. 54 | min. 54 |
| Rolling element made of tool steel, hardness in HRC | min. 56 | min. 56 | min. 56 | min. 56 | min. 56 | min. 56 |

n/a not available

3 Overview of product

The following special versions do not apply in respect of every rail cross-section or every rail length. For details and technical information, see chapter 7.

| Special versions | Order code (5) |  | | | | | |
|--|----------------|--|-----|-----|-----|-----|-----|
| | | R | RD | RN | RNG | N/O | M/V |
| Precision in special quality (1) | SQ | ✓ | ✓ | ✓ | ✓ | ✓ | ✓ |
| Precision in super special quality (1) | SSQ | ✓ | ✓ | ✓ | ✓ | ✓ | ✓ |
| Linear guideways made of corrosion-resistant steel (2) | RF | ✓ | ✓ | ✓ | ✓ | ✓ | ✓ |
| Run-ins rounded | EG | ✓ | ✓ | ✓ | ✓ | ✓ | ✓ |
| Prepared for roller cage type EE | EE | ✓ | ✓ | n/a | n/a | n/a | n/a |
| Multi-part linear guideways | ZG | ✓ | ✓ | ✓ | ✓ | ✓ | ✓ |
| Pair of height-matched guideways | HA EHA | ✓ | ✓ | ✓ | ✓ | ✓ | ✓ |
| DURALLOY® coating (3) | DU | ✓ | ✓ | ✓ | ✓ | ✓ | ✓ |
| DryRunner coating (4) | DR | n/a | n/a | ✓ | ✓ | n/a | n/a |
| Cage control FORMULA-S | KS | n/a | n/a | ✓ | ✓ | n/a | n/a |
| Cage control | KZST | n/a | n/a | n/a | n/a | ✓ | ✓ |
| Various versions of fixing holes | V, G, D | ✓ | ✓ | ✓ | ✓ | ✓ | ✓ |

(1) There are limitations relating to:
 - corrosion-resistant steel
 - coatings
 - maximum rail length

(2) There are limitations relating to:
 - Maximum rail length (in normal quality as well as in options SQ and SSQ)
 - Hardness of the steel. This is reduced to a min. 54 HRC, which affects the service life of the linear guideway

(3) - The special versions ZG and SSQ are not possible
 - Special quality (SQ) only on request

(4) - DryRunner® supports operating without a lubricant. Due to increased cage creep we recommend the additional use of the option «cage control FORMULA-S»
 - Options ZG and SSQ cannot be supplied. Option SQ on request
 - There are limitations concerning maximum rail length
 - This option is not available for the sizes RN/RNG 9 and RN/RNG 12

(5) - Order reference, see p.139

n/a not available

3 Overview of product

3.2 An overview of recirculating units

The SCHNEEBERGER range of recirculating units offers you perfect solutions for your specific applications



| | SK | SKD | SKC | SR | NRT |
|---|-----|-----|-----|-----|-----|
| For features and dimension table, see chapter 6 | 6.1 | 6.1 | 6.2 | 6.3 | 6.4 |

Assessment of the advantages

Parameter: Low displacement force & high level of smoothness

| | | | | | |
|-----------|-----|------|------|-----|-----|
| - balls | +++ | ++++ | ++++ | n/a | n/a |
| - rollers | n/a | n/a | n/a | ++ | ++ |

Parameter: High loading capacity

| | | | | | |
|-----------|-----|-----|-----|-----|------|
| - balls | ++ | ++ | + | | n/a |
| - rollers | n/a | n/a | n/a | +++ | ++++ |

Legend:

- ++++ best choice
- +++
- ++
- + good choice
- n/a not available

Performance parameters

| | | | | | |
|--|-----------------|-----------------|--------------------|-----------------|-----------------|
| Max. acceleration in m/s ² | 50 | 50 | 50 | 50 | 50 |
| Max. speed in m/s | 2 | 2 | 2 | 2 | 1 |
| Operating temperature in degrees Celsius | -40° C - +80° C | -40° C - +80° C | -150° C to +200° C | -40° C - +80° C | -40° C - +80° C |

Material (standard)

| | | | | | |
|---|--|--|--------------------|--|---------|
| Supporting structure of tool steel, hardness in HRC | 58 - 62 | 58 - 62 | 58 - 62 coated | 58 - 62 | 58 - 62 |
| Rolling element made of tool steel, hardness in HRC | 58 - 64 | 58 - 64 (Damping elements made of plastic) | n/a | 58 - 64 | 58 - 64 |
| Rolling element made of ceramic (Balls made of Teflon® are situated between the ceramic balls) | n/a | n/a | ✓ | n/a | n/a |
| Redirection unit | Size 1, 2, 9 and 12 made of anodized aluminium Sizes 3 and 6 depending on the length made of plastic or aluminium | Depending on the length made of plastic or aluminium | tool steel, coated | Depending on the length made of plastic or aluminium | Plastic |

Special versions

Detailed technical information on the options listed below can be found in chapter 8

| | Order code | SK | SKD | SKC | SR | NRT |
|--|------------|-----|-----|-----|-----|-----|
| Matched (height-matched) | GP | ✓ | ✓ | ✓ | ✓ | ✓ |
| Connection for centralised lubrication | ZS | n/a | n/a | n/a | n/a | ✓ |

n/a not available

3 Overview of product

3.3 Earlier generations of the product

Examples of earlier generations of the product, which we are also pleased to manufacture for you today:

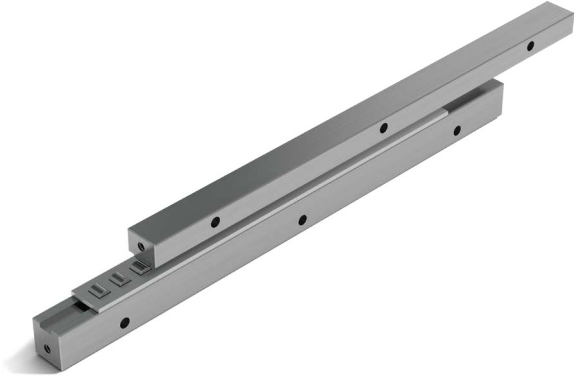

Linear guideway type W/Z



Linear guideway type L/M or J/K



Linear guideway type A



Linear guideway type B



Linear guideway type C



Linear guideway type D



Linear guideway type E

3 Overview of product

3.4 Slideways

In some applications slideways/slide bearings are more suitable than roller-contact bearings. For such applications SCHNEEBERGER produces steel strips, which are produced with a slideway lining selected by the customer (e.g. Turcite B, Glycodur or Ampco) and then re-ground.

The slideways can be supplied in standardised dimensions for the roller-contact bearing or on a customer-specific basis too.

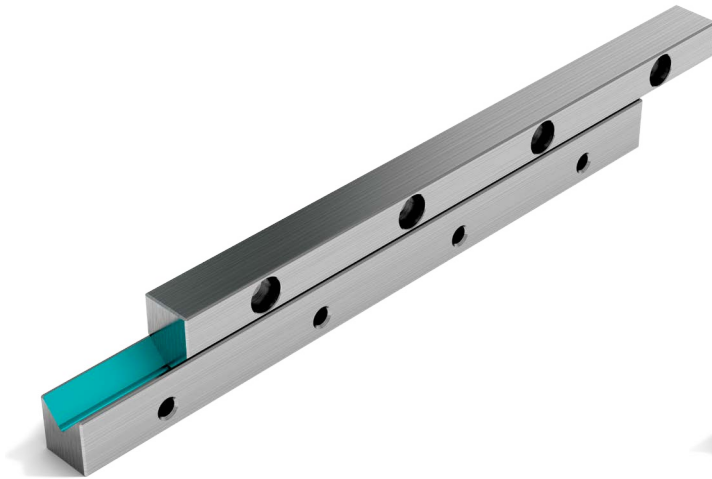

Slideways

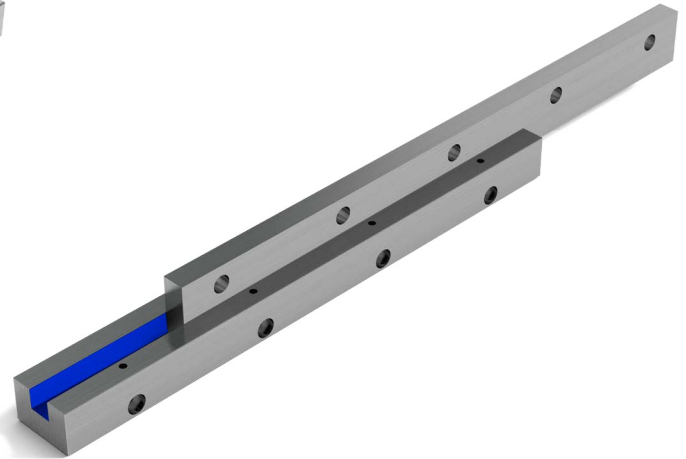

Flat strips

3.5 Application-specific solutions



Our linear guideways can be universally deployed, but can also be configured on a customer-specific basis ex works. Amongst other things, SCHNEEBERGER offers the following services:

- modified standard
- customer-specific design
- special greasing (cleanroom, vacuum, extraordinary temperature ranges, etc.)
- special packaging

4 Applications

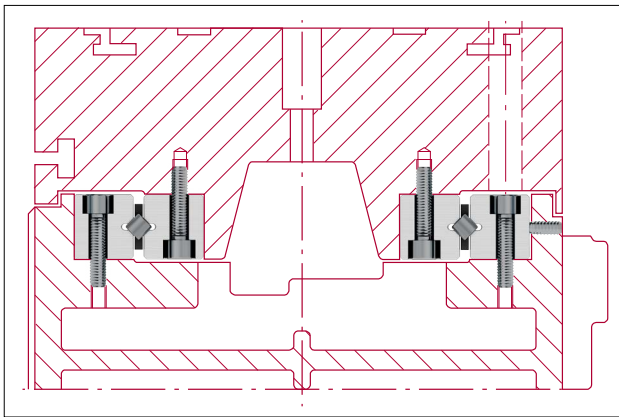

Linear guideway for a tool grinding machine table

Precision-grinding on tool grinding machines requires a stick-slip-free and frictionless guideway to allow longitudinal movement of the table.

Possible SCHNEEBERGER products:

- 4 linear guideways type R 9-800
- 2 roller cages AC 9 x 33 rollers
- 8 end pieces GA 9, GB 9

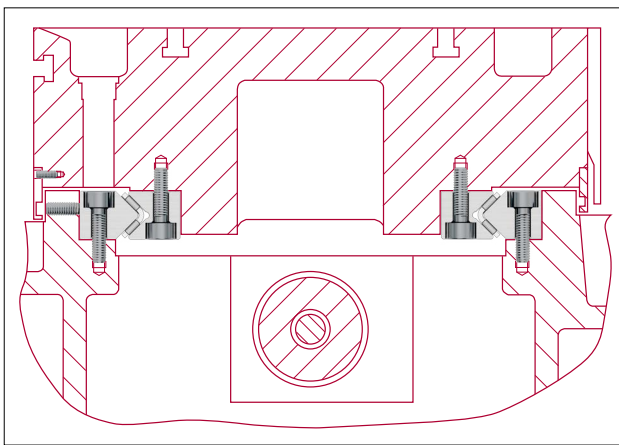

Table bearing for an internal cylindrical grinding machine

Internal cylindrical grinding robots require absolutely zero-backlash table guiding in order to meet the stringent requirements of today's grinding technology.

The grinding table displayed is mounted with type N/O linear guideways whose V-shaped needle cages are connected to an oil impulse lubrication system. This creates the conditions needed to control high table speeds with minimal force applied.

Possible SCHNEEBERGER products:

- 2 linear guideways type O 2535-1'000
- 2 linear guideways type N 2535-1'000
- 2 needle cages HW 20 x 725
- 4 end pieces GH 2535 without wipers

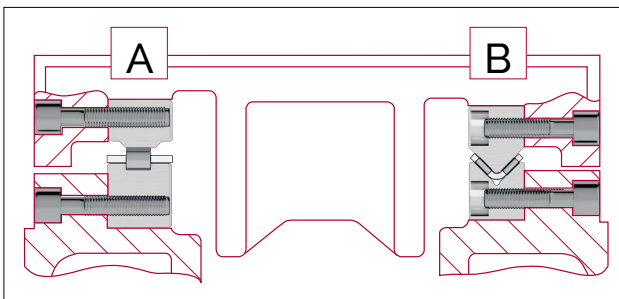

Open configuration (floating bearings) for heavy surface grinding machine

Surface-mounted roller guides then come into play particularly when large and heavy workpieces are being machined. The weights of table and workpiece and the grinding pressure have a vertical action on the roller guides.

Possible SCHNEEBERGER products:

- A**
 - 1 linear guideway spec. 45 x 35 x 600-EG (1)
 - 1 linear guideway spec. 45 x 42.5 x 1'000
 - 1 roller cage H 25 x 810 mm
 - 2 end pieces special
- B**
 - 1 linear guideway type N 3555-600-EG (1)
 - 1 linear guideway type O 3555-1'000
 - 1 needle cage SHW 30 x 810 mm
 - 2 end pieces GW 3555

Cost-effectiveness, simple assembly and a high level of running accuracy characterise this configuration. Expansion of the table resulting from the effect of heat without limitations is also prevented thanks to characterize expansion options.

Its construction is simple and cost-effective. The N/O linear guideway assumes the task of being the lateral linear guideway for the table. As the surface guideway is adjusted level with the N/O, the linear guideway systems can be interchanged - depending on whether the grinding spindle is mounted to the right or left.

⁽¹⁾ see chapter 7

4 Applications

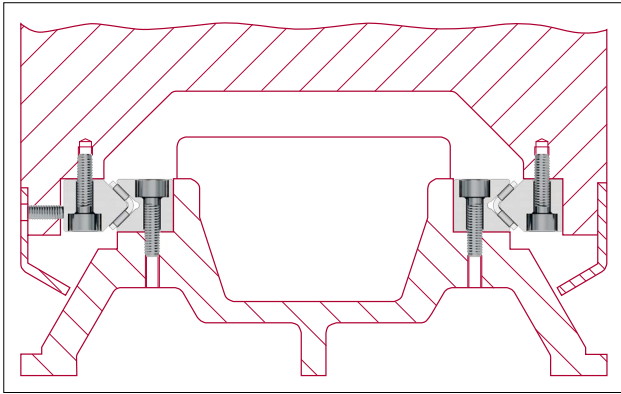

Possible SCHNEEBERGER products:

- 2 linear guideways N 3045-900
- 2 linear guideways O 3045-900
- 2 needle cages SHW 25 x730 mm
- 8 end pieces GF 3045

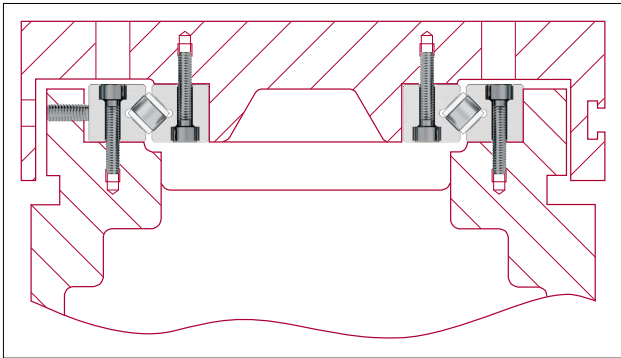

Possible SCHNEEBERGER products:

- 2 linear guideways RNG 9-700
- 2 linear guideways RNG 9-450-EG ⁽¹⁾
- 2 roller cages KBN 9 x 43 rollers
- 4 end pieces GCN 9

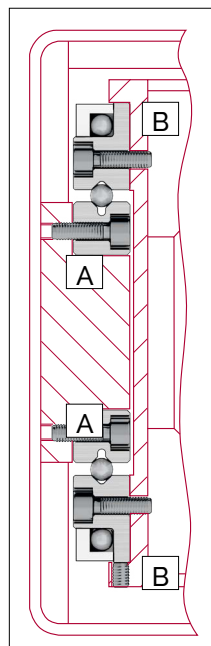

Closed V guideway for surface grinding machines

Economic perspectives also determine the structural design of the tables guideways for surface grinding machines. The V-shaped arrangement of the roller guideways creates a closed linear guideway that can be loaded for forces and moments from all directions.

The few components ensure rapid and simple assembly. The stroke and table length ratios are optimal for the use of roller guideways. The basic surfaces of the roof-shaped linear guideways can be machined with extreme efficiency and precision because they are on the same plane. These surfaces also form the basis for achieving high levels of running accuracy.

V guideway for heavy tool grinding machines

Tool grinding machines place very high demands on the roller guideway system of the machine table. High level of running accuracy, minimal friction, stick-slip effect and protected arrangement of the roller guideways are the most important requirements.

The RNG roller guideways used here are ideally suited to this task thanks to their high load carrying capacity. The table construction allows drive mechanisms to be accommodated; the upper part of the table can also be installed with great ease. The preload of the linear guideway system can also be easily set subsequently.

Infeed device

The infeed device working in vacuum places high demands on the linear guideway system. A U-shaped support forms the supporting element and also acts as the take-up for the linear guideways. The whole system is made of a non-corrosive material and works vertically with a stroke of 2'700 mm.

Linear guideways, which are assembled in the U-shaped basic component, and 4 type SK rolling elements form the actual guide system. Two of the four rolling elements can be adjusted externally and so support optimal preload setting. All individual components of the rolling elements are made out of stainless steel or aluminium.

Possible SCHNEEBERGER products:

- A** 4 linear guideways R 9-1400-RF ⁽¹⁾-ZG ⁽¹⁾
- B** 4 recirculating units SK 9-150-RF ⁽¹⁾

⁽¹⁾ see chapter 7

4 Applications



Patient tables

Highly developed, automatic patient tables are used, amongst other things, in computer tomography (CT), magnetic resonance tomography (MRT) or radiotherapy.

All kinematic processes place the highest demands on the linear guideway systems in terms of running accuracy, smoothness, maintenance-free operation, rigidity, ease of installation and radiation resistance.

Possible SCHNEEBERGER products:

R 9 linear guideways



Microtome

Microtomes are cutting devices used to create wafer-thin sections. They are used for microscopic preparations (for example, biological tissue) or analysis of plastics.

Biological material is normally hardened before being cut by means of fixing and then made sliceable by means of «embedding», i.e. inclusion with a fluid substance such as paraffin or synthetic resin. The thickness of the slices is significantly smaller than the diameter of a human hair and is typically around 1 to 100 μm .

Due to these extraordinary requirements, the most stringent demands in terms of smoothness and precision are placed on the linear guideway systems.

Possible SCHNEEBERGER products:

RNG 4 linear guideways

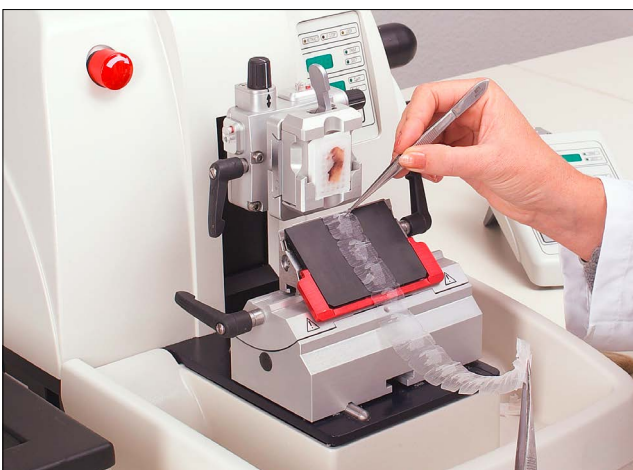

4 Applications



Wire bonder

Wire bonding is the preferred method for making bonds between an integrated circuit (IC) and a printed circuit board. Wire bonding generally represents the most cost-effective and flexible bonding technology with which the thinnest wires are used for bonding electrical connections.

Aluminium, copper or gold wire from 15 µm in diameter is usually used for this technology. The requirements in respect of the linear guideway system for a wire bonder are correspondingly stringent.

- The highest precision and rigidity
- The highest speeds
- The highest level of smoothness
- The highest level of reliability.

Possible SCHNEEBERGER products:

SCHNEEBERGER supplies prestigious manufacturers of wire bonders with customer-specific linear guideway systems.

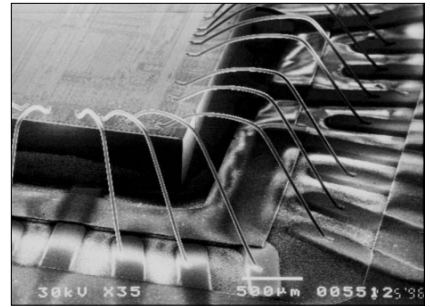

Aluminium wires with a diameter of 25 µm bond the electrodes of microchip with the conductor tracks of a carrier substrate.

Large-scale machining center

To ensure that it is possible to manufacture with high precision under the most stringent loads, rigid and precise linear guideway systems are critical.

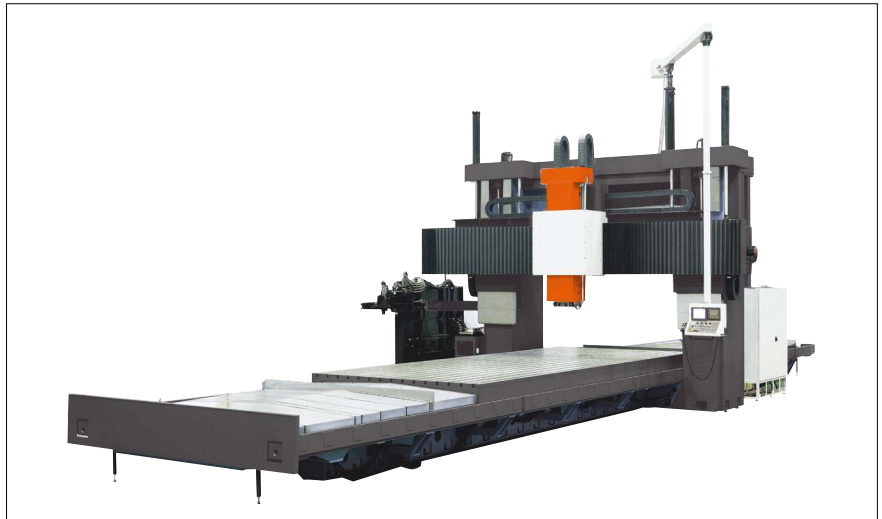

Possible SCHNEEBERGER products:

- [A] MONORAIL MR 65
- [B] recirculating unit NRT with preload wedge NRV

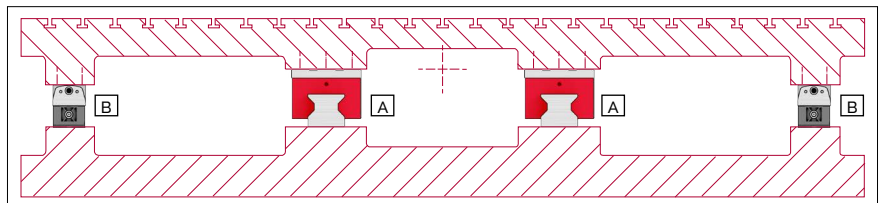

5 Product specifications

5.1 Type R and RD



Type R with balls

Typ R with rollers

Type RD

With its type R, SCHNEEBERGER has developed the first standardized cross roller guide, which has defined the global industry standard.

The RD double V-shaped guide supplements the R linear guideway and supports space-saving and cost-effective solutions.

Type R benchmark data

Track and surface quality

- Finely ground supporting and/or locating surfaces and tracks (90° V-profile)

Materials (standard)

- Rails from through hardened tool steel 1.2842, hardness 58 – 62 HRC
The sizes R/RD 1 and 2 are made out of tool steel 1.3505
- For non-corrosive guideways tool steel 1.4034 and 1.4112 is used
- Rolling element made of through hardened roller bearing steel, hardness 58 – 64 HRC

Rolling element

- Ball or roller

Speed

- 1 m/s

Acceleration

- 50 m/s²

Accuracy

- R and RD linear guideways are available in three quality classes (see chapter 9)

Operating temperatures

- -40° C to +80° C

The R and RD design can be combined with the following products:

- recirculating unit type SK, SKC and SR

5 Linear guideways

Dimensions and load capacities type R

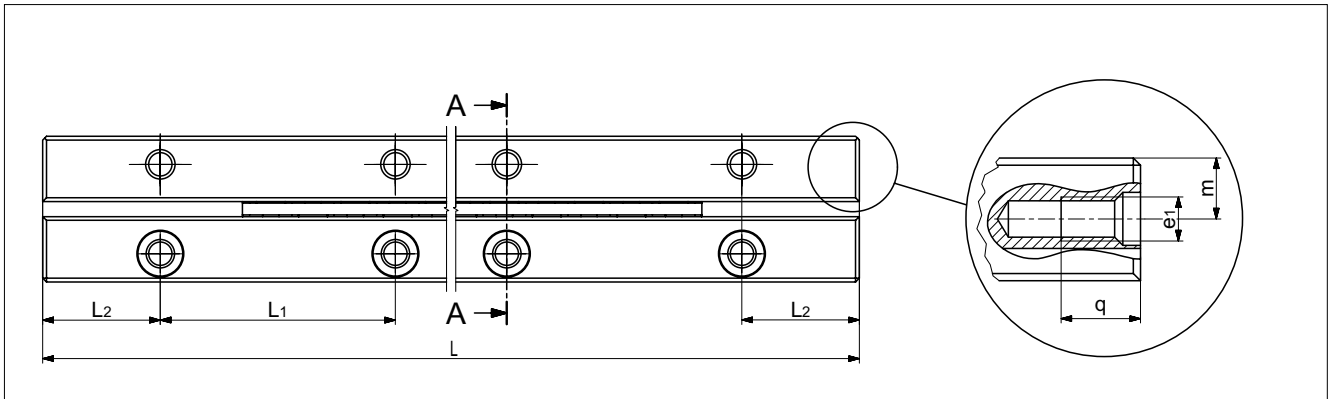

| Type | Size | L in mm ⁽¹⁾ | Weight in g | A | B/B ₂ ⁽²⁾ | Dw | J | L ₁ | L ₂ | N | d | e | e ₁ | f | g | m | q | Options (see chapter 7) | Accessories ⁽³⁾ |
|------|------|------------------------|-------------|-----|---------------------------------|----|-----|----------------|----------------|-----|-----|----|----------------|------|-----|-----|-----|---|---|
| | | | | mm | | | | | | | | | | | | | | | |
| R | 1 | 20 | 3 | 8.5 | 4 | 15 | 3.9 | 10 | 5 | 18 | 3 | M2 | M16 | 165 | 2.6 | 19 | 2.5 | SQ SSQ RF EG ZG HA DU | Cage: - AA-RF 1 - AC 1 - AK 1 End screw: - GA 1 End piece: - GB 1 |
| | | 30 | 4 | | | | | | | | | | | | | | | | |
| | | 40 | 5 | | | | | | | | | | | | | | | | |
| | | 50 | 6 | | | | | | | | | | | | | | | | |
| | | 60 | 7 | | | | | | | | | | | | | | | | |
| | | 70 | 8 | | | | | | | | | | | | | | | | |
| | | 80 | 9 | | | | | | | | | | | | | | | | |
| | | 100 | 12 | | | | | | | | | | | | | | | | |
| 120 | 14 | | | | | | | | | | | | | | | | | | |
| R | 2 | 30 | 8 | 12 | 6 | 2 | 5.5 | 15 | 7.5 | 2.5 | 4.4 | M3 | M2.5 | 2.55 | 4 | 2.7 | 3.5 | SQ SSQ RF EG ZG HA DU | Cage: - AA-RF 2 - AC 2 - AK 2 End screw: - GA 2 End piece: - GB 2 Fastening screw: - GD 3 |
| | | 45 | 11 | | | | | | | | | | | | | | | | |
| | | 60 | 14 | | | | | | | | | | | | | | | | |
| | | 75 | 17 | | | | | | | | | | | | | | | | |
| | | 90 | 20 | | | | | | | | | | | | | | | | |
| | | 105 | 23 | | | | | | | | | | | | | | | | |
| | | 120 | 26 | | | | | | | | | | | | | | | | |
| | | 150 | 34 | | | | | | | | | | | | | | | | |
| 180 | 40 | | | | | | | | | | | | | | | | | | |
| R | 3 | 50 | 23 | 18 | 8 | 3 | 8.3 | 25 | 125 | 3.5 | 6 | M4 | M3 | 3.3 | 4.8 | 4.1 | 7 | SQ SSQ RF EG ZG HA DU | Cage: - AA-RF 3 - AC 3 - AK 3 End screw: - GA 3 End pieces: - GB 3 - GC 3 - GC-A 3 Fastening screw: - GD 3 - GD 4 |
| | | 75 | 34 | | | | | | | | | | | | | | | | |
| | | 100 | 45 | | | | | | | | | | | | | | | | |
| | | 125 | 56 | | | | | | | | | | | | | | | | |
| | | 150 | 67 | | | | | | | | | | | | | | | | |
| | | 175 | 78 | | | | | | | | | | | | | | | | |
| | | 200 | 89 | | | | | | | | | | | | | | | | |
| | | 225 | 100 | | | | | | | | | | | | | | | | |
| | | 250 | 111 | | | | | | | | | | | | | | | | |
| | | 275 | 122 | | | | | | | | | | | | | | | | |
| | | 300 | 133 | | | | | | | | | | | | | | | | |
| | | 350 | 156 | | | | | | | | | | | | | | | | |
| 400 | 178 | | | | | | | | | | | | | | | | | | |
| 500 | 222 | | | | | | | | | | | | | | | | | | |
| 600 | 267 | | | | | | | | | | | | | | | | | | |

⁽¹⁾ The lengths listed are standard; other lengths are of course available. The maximum lengths are listed on page 26.

⁽²⁾ B designates the width of a guideway. B₂ designates the width over both guideways.

⁽³⁾ Select accessories as follows: Cage type: page 27 and 28, end pieces: pages 29 and, end and fixing screws: page 30

5 Linear guideways

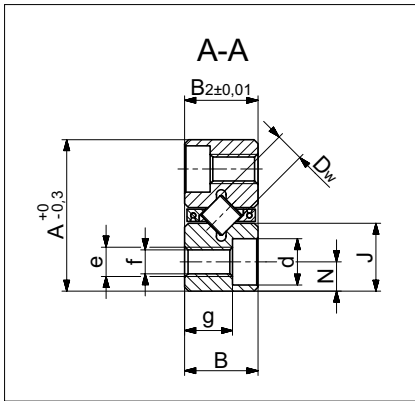

| Type | Size | L in mm ⁽¹⁾ | Weight in g | A | B/B ₂ ⁽²⁾ | Dw | J | L ₁ | L ₂ | N | d | e | e ₁ | f | g | m | q | Options (see chapter 7) | Accessories ⁽³⁾ |
|-------|-------|------------------------|-------------|----|---------------------------------|----|------|----------------|----------------|----|------|-----|----------------|-----|------|------|----|---|--|
| | | | | mm | | | | | | | | | | | | | | | |
| R | 6 | 100 | 145 | 31 | 15 | 6 | 13.9 | 50 | 25 | 6 | 9.5 | M6 | M5 | 5.2 | 9.8 | 6.9 | 9 | SQ SSQ RF EG ZG HA DU | Cage: - AA-RF 6 - AC 6 - AK 6 End screw: - GA 6 End pieces - GB 6 - GC 6 - GC-A 6 Fastening screw: - GD 6 - GD 9 |
| | | 150 | 220 | | | | | | | | | | | | | | | | |
| | | 200 | 295 | | | | | | | | | | | | | | | | |
| | | 250 | 370 | | | | | | | | | | | | | | | | |
| | | 300 | 445 | | | | | | | | | | | | | | | | |
| | | 350 | 520 | | | | | | | | | | | | | | | | |
| | | 400 | 595 | | | | | | | | | | | | | | | | |
| | | 450 | 670 | | | | | | | | | | | | | | | | |
| | | 500 | 745 | | | | | | | | | | | | | | | | |
| | | 600 | 895 | | | | | | | | | | | | | | | | |
| | | 700 | 1'045 | | | | | | | | | | | | | | | | |
| 800 | 1'195 | | | | | | | | | | | | | | | | | | |
| 1'000 | 1'500 | | | | | | | | | | | | | | | | | | |
| R | 9 | 200 | 630 | 44 | 22 | 9 | 19.7 | 100 | 50 | 9 | 10.5 | M8 | M6 | 6.8 | 15.8 | 9.8 | 9 | SQ SSQ RF EG EE ZG HA DU | Cage: - AC 9 - AK 9 - EE 9 End screw: - GA 9 End pieces - GB 9 - GC 9 - GC-A 9 Fastening screw: - GD 9 - GD 12 |
| | | 300 | 945 | | | | | | | | | | | | | | | | |
| | | 400 | 1'260 | | | | | | | | | | | | | | | | |
| | | 500 | 1'575 | | | | | | | | | | | | | | | | |
| | | 600 | 1'890 | | | | | | | | | | | | | | | | |
| | | 700 | 2'205 | | | | | | | | | | | | | | | | |
| | | 800 | 2'520 | | | | | | | | | | | | | | | | |
| | | 900 | 2'835 | | | | | | | | | | | | | | | | |
| | | 1'000 | 3'150 | | | | | | | | | | | | | | | | |
| | | 1'100 | 3'465 | | | | | | | | | | | | | | | | |
| | | 1'200 | 3'780 | | | | | | | | | | | | | | | | |
| 1'400 | 4'410 | | | | | | | | | | | | | | | | | | |
| R | 12 | 200 | 1'040 | 58 | 28 | 12 | 25.9 | 100 | 50 | 12 | 13.5 | M10 | M8 | 8.5 | 19.8 | 12.9 | 12 | SQ SSQ RF EG ZG HA DU | Cage: - AC 12 - AK 12 End screw: - GA 12 End pieces: - GB 12 - GC 12 - GC-A 12 Fastening screw: - GD 12 - GD 15 |
| | | 300 | 1'560 | | | | | | | | | | | | | | | | |
| | | 400 | 2'090 | | | | | | | | | | | | | | | | |
| | | 500 | 2'615 | | | | | | | | | | | | | | | | |
| | | 600 | 3'140 | | | | | | | | | | | | | | | | |
| | | 700 | 3'665 | | | | | | | | | | | | | | | | |
| | | 800 | 4'190 | | | | | | | | | | | | | | | | |
| | | 900 | 4'715 | | | | | | | | | | | | | | | | |
| | | 1'000 | 5'240 | | | | | | | | | | | | | | | | |
| | | 1'100 | 5'765 | | | | | | | | | | | | | | | | |
| | | 1'200 | 6'290 | | | | | | | | | | | | | | | | |

⁽¹⁾ The lengths listed are standard; other lengths are of course available. The maximum lengths are listed on page 26.

⁽²⁾ B designates the width of a guideway. B₂ designates the width over both guideways.

⁽³⁾ Select accessories as follows: Cage type: page 27 and 28, end pieces: pages 29 and, end and fixing screws: page 30

5 Linear guideways

Dimensions and load capacities of type RD

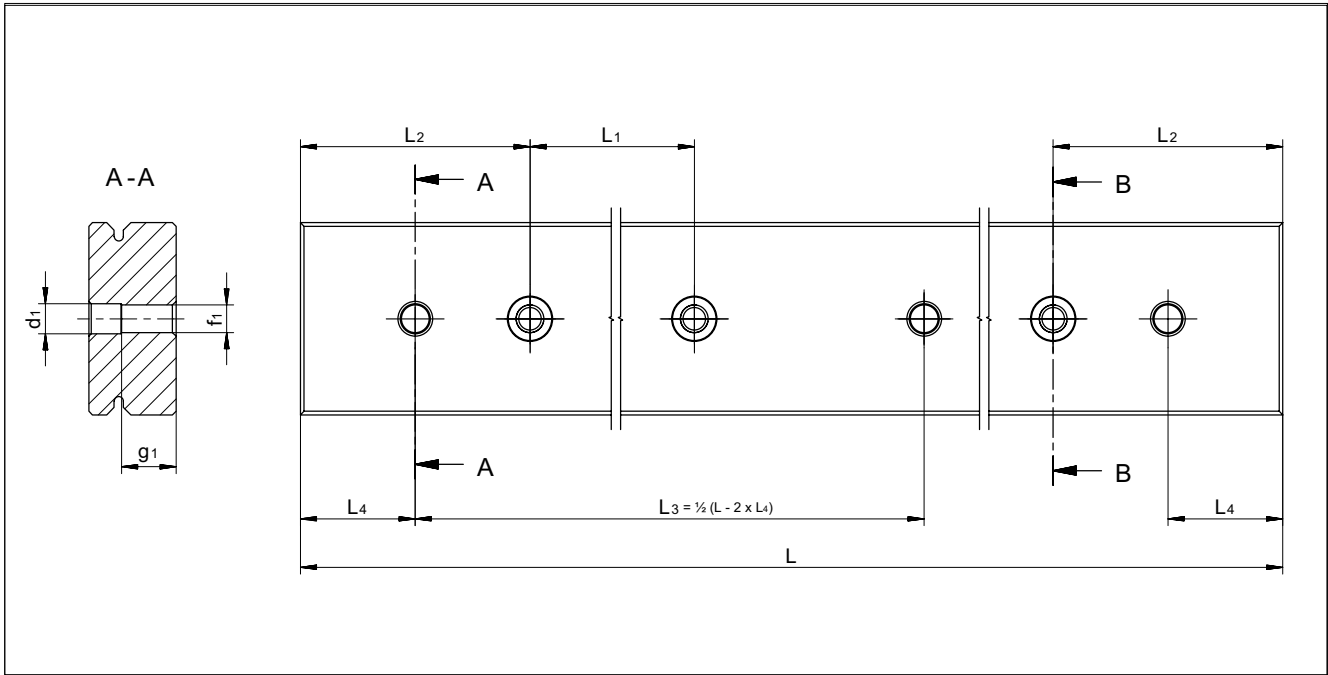

| Type | Size | L in mm ⁽¹⁾ | Weight in g | A | B | B ₁ | B ₂ | Dw | J | L ₁ | L ₂ | Q | d | e | f | g | k | Options (see chapter 7) | Accessories ⁽³⁾ | |
|------|------|------------------------|-------------|----|---|----------------|----------------|----|------|----------------|----------------|------|-----|----|------|-----|---|-----------------------------------|--|--|
| | | | | mm | | | | | | | | | | | | | | | | |
| RD | 1 | 100 | 50 | | | | | | | | | | | | | | | SQ SSQ RF EG ZG DU | Cage: - AA-RF 1 - AC 1 - AK 1 Fastening screw: - GD 3 | |
| | | 150 | 70 | 22 | 4 | 5.5 | 6 | 15 | 12.8 | 25 | 12.5 | 13.5 | 4.4 | M3 | 2.55 | 3.5 | 2 | | | |
| | | 200 | 100 | | | | | | | | | | | | | | | | | |
| RD | 2 | 200 | 220 | | | | | | | | | | | | | | | SQ SSQ RF EG ZG DU | Cage: - AA-RF 2 - AC 2 - AK 2 Fastening screw: - GD 3 - GD 4 | |
| | | 300 | 320 | 30 | 6 | 8.5 | 9 | 2 | 17 | 50 | 25 | 18 | 6 | M4 | 3.35 | 5.4 | 3 | | | |
| | | 400 | 430 | | | | | | | | | | | | | | | | | |
| RD | 3 | 300 | 690 | | | | | | | | | | | | | | | SQ SSQ RF EG ZG DU | Cage: - AA-RF 3 - AC 3 - AK 3 Fastening screw: - GD 4 - GD 6 | |
| | | 400 | 920 | | | | | | | | | | | | | | | | | |
| | | 500 | 1150 | 46 | 8 | 11.5 | 12 | 3 | 26.6 | 50 | 25 | 28 | 7.5 | M5 | 4.2 | 7.3 | 4 | | | |
| | | 600 | 1380 | | | | | | | | | | | | | | | | | |
| | | 800 | 1840 | | | | | | | | | | | | | | | | | |

⁽¹⁾ The lengths listed are standard; other lengths are of course available. The maximum lengths are listed on page 26.

⁽²⁾ Positioning hole option available upon customer request (per NZ customer drawing)

⁽³⁾ Select accessories as follows: Cage type: page 27 and 28, end pieces: pages 29 and, end and fixing screws: page 30

5 Linear guideways

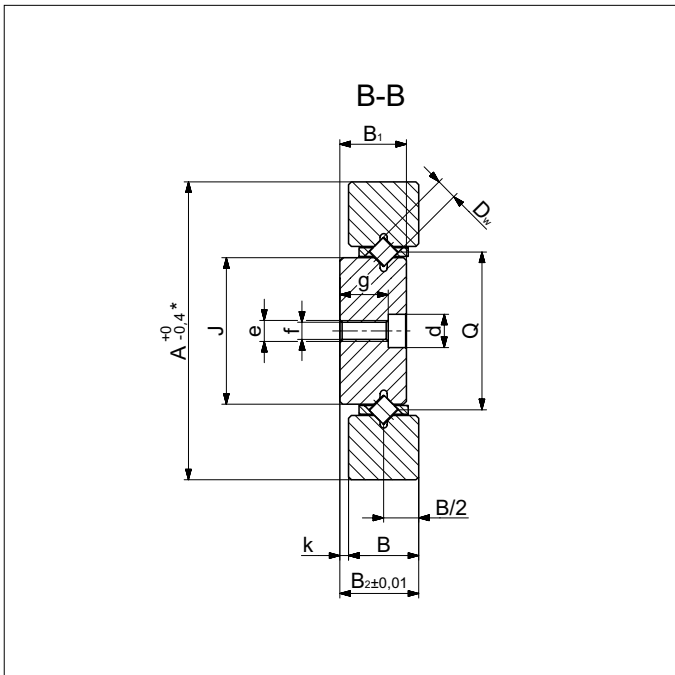

*applies to the mix of type R linear guideways of the same sizes

| Type | Size | L in mm | Weighting | A | B | B ₁ | B ₂ | Dw | J | L ₁ | L ₂ | Q | d | e | f | g | k | Options (see chapter 7) | Accessories ⁽³⁾ |
|------|------|------------|------------|-----|----|----------------|----------------|----|------|----------------|----------------|----|------|-----|-----|------|---|---|--|
| | | | | mm | | | | | | | | | | | | | | | |
| RD | 6 | On request | On request | 76 | 15 | 19 | 20 | 6 | 41.8 | 100 | 50 | 45 | 9.5 | M6 | 5.2 | 13.8 | 5 | SQ SSQ RF EG ZG DU | Cage: - AA-RF 6 - AC 6 - AK 6 Fastening screw: - GD 6 - GD 9 |
| RD | 9 | Max. 3000 | On request | 116 | 22 | 27 | 28 | 9 | 67.4 | 100 | 50 | 72 | 10.5 | M8 | 6.8 | 20.8 | 6 | SQ SSQ RF EG EE ZG DU | Cage: - AC 9 - AK 9 - EE 9 Fastening screw: - GD 9 |
| RD | 12 | Max. 3000 | On request | 135 | 28 | 34 | 35 | 12 | 70.8 | 100 | 50 | 77 | 13.5 | M10 | 8.5 | 25.8 | 7 | SQ SSQ RF EG ZG DU | Cage: - AC 12 - AK 12 Fastening screw: - GD 12 - GD 15 |

⁽²⁾ Positioning hole option available upon customer request (per NZ customer drawing)

⁽³⁾ Select accessories as follows: Cage type: page 27 and 28, end pieces: pages 29 and, end and fixing screws: page 30

5 Linear guideways

Maximum lengths for type R

| Type / Size | Quality class | Max. lengths in standard material (in mm) | Max lengths in non-corrosive material (in mm) |
|-------------|---------------|---|---|
| R 1 | NQ | 200 | 150 |
| | SQ | | |
| | SSQ | 120 | 120 |
| R 2 | NQ | 300 | 300 |
| | SQ | 300 | 300 |
| | SSQ | 180 | 180 |
| R 3 | NQ | 800 | 600 |
| | SQ | | |
| | SSQ | 600 | |
| R 6 | NQ | 1500 | 1400 |
| | SQ | | 1200 |
| | SSQ | 1200 | 900 |
| R 9 | NQ | 3000 | 3000 |
| | SQ | | |
| | SSQ | | |
| R 12 | NQ | 3000 | 3000 |
| | SQ | | |
| | SSQ | | |

Maximum lengths for type RD

| Type / Size | Quality class | Max. lengths in standard material (in mm) | Max lengths in non-corrosive material (in mm) |
|-------------|---------------|---|---|
| RD 1 | NQ | 300 | 300 |
| | SQ | | |
| | SSQ | | |
| RD 2 | NQ | 500 | 500 |
| | SQ | | |
| | SSQ | | |
| RD 3 | NQ | 1200 | 600 |
| | SQ | | |
| | SSQ | | |
| RD 6 | NQ | 1500 | 900 |
| | SQ | | |
| | SSQ | 1200 | |
| RD 9 | NQ | 3000 | 3000 |
| | SQ | | |
| | SSQ | | |
| RD 12 | NQ | 3000 | 3000 |
| | SQ | | |
| | SSQ | | |

Rail chamfer

The detail of the rail chamfer is shown in the chart below. Please note that the part number and company logo are marked opposite to the datum and supporting surfaces.

| Type / Size | Rail chamfer of reference edges in mm |
|-------------|---------------------------------------|
| R 1 | 0.3 x 45° |
| R 2 | 0.3 x 45° |
| R 3 | 0.6 x 45° |
| R 6 | 0.8 x 45° |
| R 9 | 0.8 x 45° |
| R 12 | 1.0 x 45° |

5 Linear guideways

Accessories for type R and RD

Roller cage type AC

Compatible with:

Linear guideway type R and RD,
 Sizes 1 to 12

Design:

Rollers fixed in place

Installation method:

For normal application and certain
 overrunning cage applications

Material:

Sizes 1, 2 POM

Size 3 PA GF 30%

As from size 6 PA GF 30%, plastic/steel
 wire composite construction.

The wire is made out of stainless steel.

Option:

Corrosion-resistant rollers

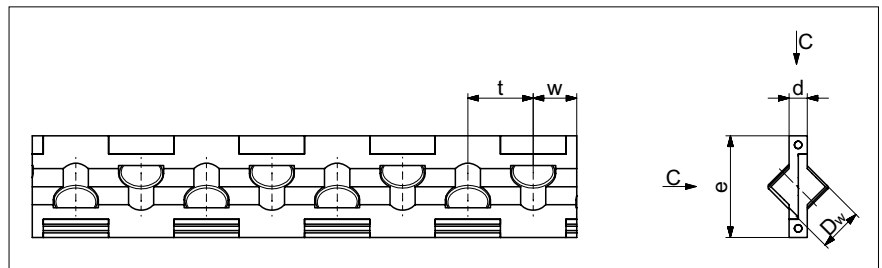

| Type | Size | Dw | d | e | t | w | C ₁₀₀ per roller in N | C ₅₀ per roller in N | max. length in mm |
|------|------|----|------|----|----|-------------|----------------------------------|---------------------------------|-------------------|
| AC | 1 | 15 | 0.45 | 35 | 3 | approx. 15 | 50 | 6150 | 80 |
| | 2 | 2 | 0.75 | 5 | 4 | approx. 2 | 85 | 10455 | 170 |
| | 3 | 3 | 1 | 7 | 5 | approx. 2.5 | 130 | 15990 | 1200 |
| | 6 | 6 | 2.5 | 14 | 9 | approx. 6 | 530 | 65190 | 1500 |
| | 9 | 9 | 3.5 | 20 | 14 | approx. 9 | 1300 | 159900 | 1500 |
| | 12 | 12 | 4.5 | 25 | 18 | approx. 11 | 2500 | 307500 | 1500 |

Roller cage type AA-RF

Compatible with:

Linear guideway type R and RD,
 Sizes 1, 2, 3 and 6

Design:

Rollers fixed in place

Installation method:

Not suitable as an overrunning cage

Material:

Cage and rollers made of corrosion-resistant steel and thus also suitable for use in vacuum

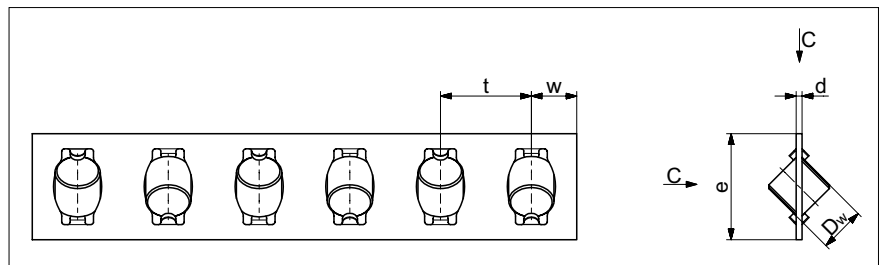

| Type | Size | Dw | d | e | t | w | C ⁽¹⁾ ₁₀₀ per roller in N | C ⁽¹⁾ ₅₀ per roller in N | max. length in mm |
|-------|------|----|------|-----|----|-------------|---|--|-------------------|
| AA-RF | 1 | 15 | 0.2 | 38 | 3 | approx. 15 | 44 | 5412 | 90 |
| | 2 | 2 | 0.25 | 5.9 | 4 | approx. 2 | 75 | 9225 | 150 |
| | 3 | 3 | 0.3 | 7.5 | 5 | approx. 2.5 | 115 | 14145 | 350 |
| | 6 | 6 | 0.8 | 14 | 12 | approx. 6 | 465 | 57195 | 1200 |

⁽¹⁾ The loading capacity C already includes the hardness factor f_H as set out in chapter 12.3

5 Linear guideways

Ball cage type AK

Compatible with:

Linear guideway type R and RD,
 Sizes 1 to 12

Design:

Balls retained

Installation method:

For normal application and certain
 overrunning cage applications

Material:

Sizes 1, 2 and 3 POM

As from size 65 PA GF 30%, plastic/
 steel wire composite construction. The
 wire is made out of stainless steel.

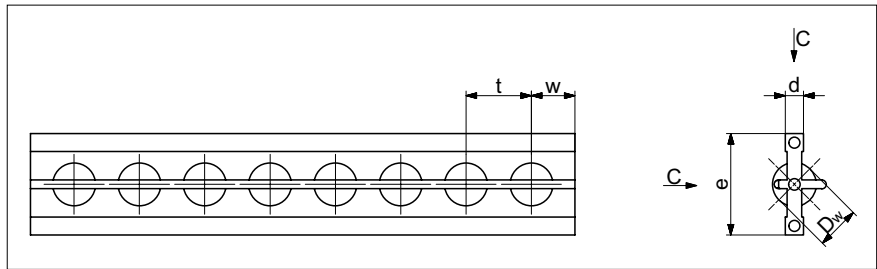

| Type | Size | Dw | d | e | t | w | C ₁₀₀ per balls in N | C ₅₀ per balls in N | max. length in mm |
|------|------|----|------|-----|-----|-------------|---------------------------------|--------------------------------|-------------------|
| AK | 1 | 15 | 0.45 | 3.5 | 2.2 | approx. 15 | 9 | 1107 | 80 |
| | 2 | 2 | 0.75 | 5 | 4 | approx. 2 | 15 | 18.45 | 100 |
| | 3 | 3 | 1 | 7 | 4.2 | approx. 2.5 | 25 | 30.75 | 180 |
| | 6 | 6 | 2.5 | 14 | 9 | approx. 6 | 65 | 79.95 | 1'500 |
| | 9 | 9 | 3.5 | 20 | 14 | approx. 9 | 150 | 184.50 | 1'500 |
| | 12 | 12 | 4.5 | 25 | 18 | approx. 11 | 260 | 319.80 | 1'500 |

Roller cage type EE

Compatible with:

Linear guideway type R and RD,
 Sizes 6

Design:

- The clearances of the guide rails are matched with the EE roller cage, which consequently works as a contaminant wiper. Displacement resistance is increased by the wiper function.
- Rollers fixed in place
- Only used with linear guideways with add-on designation EE
- Select end pieces of type GB or GC

Installation method:

Not suitable as an overrunning cage and for freely surface-mounted guideways

Material:

PE

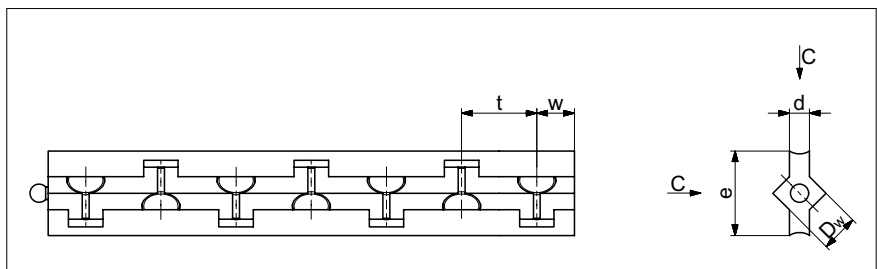

| Type | Size | Dw | d | e | t | w | C per roller in N | max. length in mm |
|------|------|----|-----|------|----|-----------|-------------------|-------------------|
| EE | 6 | 6 | 3.2 | 13.5 | 12 | approx. 6 | 530 | 1'500 |

5 Linear guideways

End screws type GA 1 to GA 12

Compatible with:
Linear guideway R 1 to R 12

Installation method:
For horizontal installation
Not suitable for cage reset

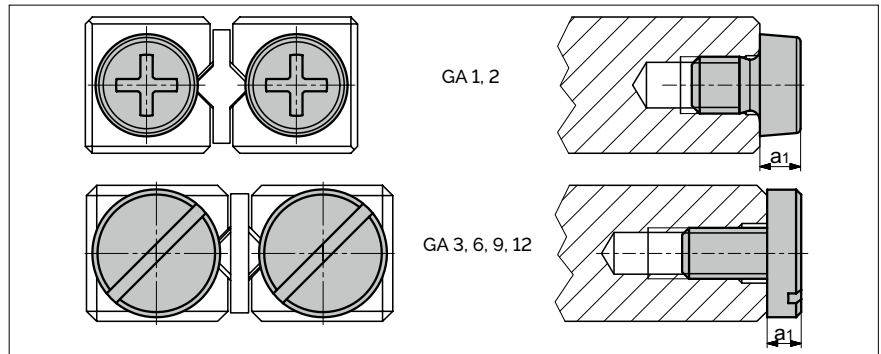

| Size | GA 1 | GA 2 | GA 3 | GA 6 | GA 9 | GA 12 |
|----------------|------|------|------|------|------|-------|
| a ₁ | 12 | 18 | 2 | 3 | 3 | 3 |

End piece type GB 1

Compatible with:
Linear guideway R 1

Installation method:
No restrictions

Scope of supply:
Including end screws

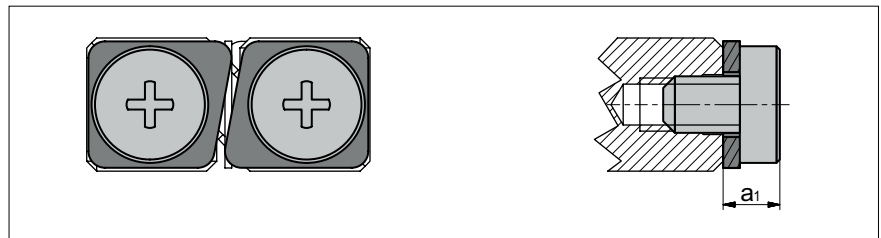

| Size | GB 1 |
|----------------|------|
| a ₁ | 17 |

End piece type GB 2

Compatible with:
Linear guideway R 2

Installation method:
No restrictions

Scope of supply:
Including end screws

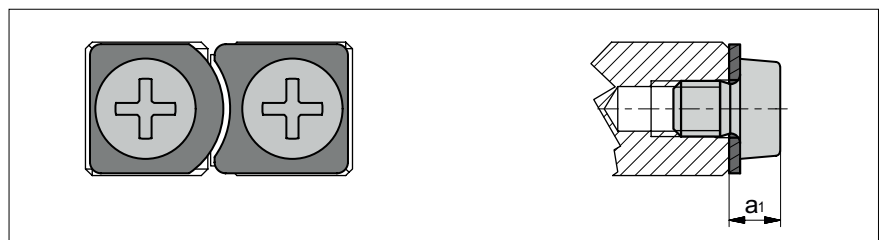

| Size | GB 2 |
|----------------|------|
| a ₁ | 2 |

End piece type GB 3 to 12

Compatible with:
Linear guideway R 3 to R 12

Installation method:
No restrictions

Scope of supply:
Including end screws

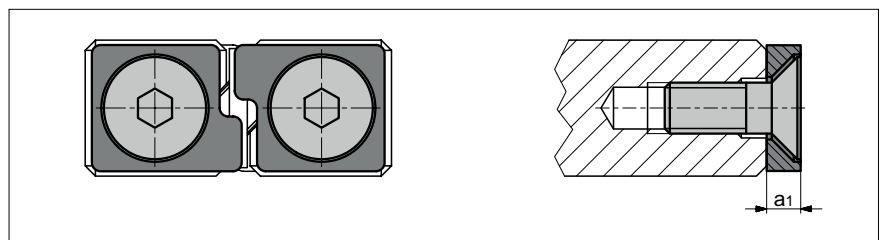

| Size | GB 3 | GB 6 | GB 9 | GB 12 |
|----------------|------|------|------|-------|
| a ₁ | 2 | 3 | 4 | 5 |

5 Linear guideways

End piece type GC 3 to GC 12

Compatible with:
Linear guideway R 3 to R 12

Installation method:
For overrunning cages

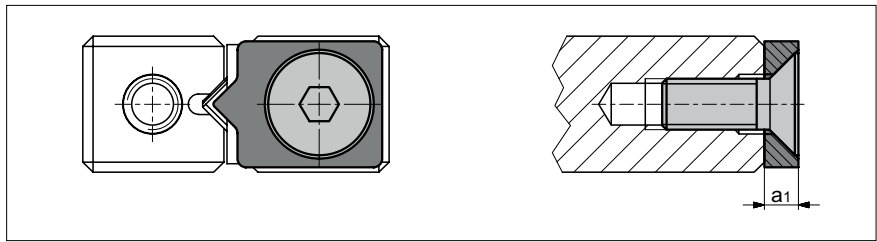

Scope of supply:
Including end screws

| Size | GC 3 | GC 6 | GC 9 | GC 12 |
|-------|------|------|------|-------|
| a_1 | 2 | 3 | 4 | 5 |

End piece type GC-A 3 to GC-A 12 (with wipers)

Compatible with:
Linear guideway R 3 to R 12

Design:
with felt wiper

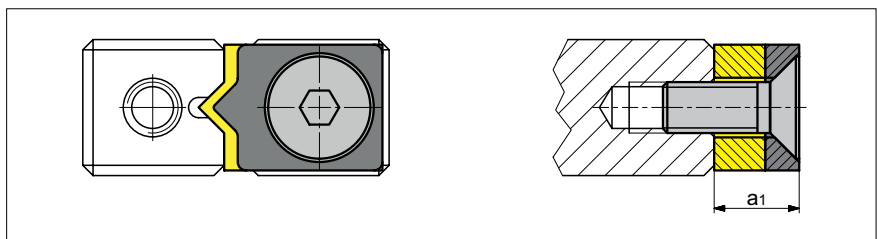

Installation method:
No restrictions

| Size | GC-A 3 | GC-A 6 | GC-A 9 | GC-A 12 |
|-------|--------|--------|--------|---------|
| a_1 | 5 | 6 | 7 | 8 |

Scope of supply:
Including end screws

Fastening screws with thin shaft type GD 3 to GD 15

Special feature:
To compensate for differences in hole pitches

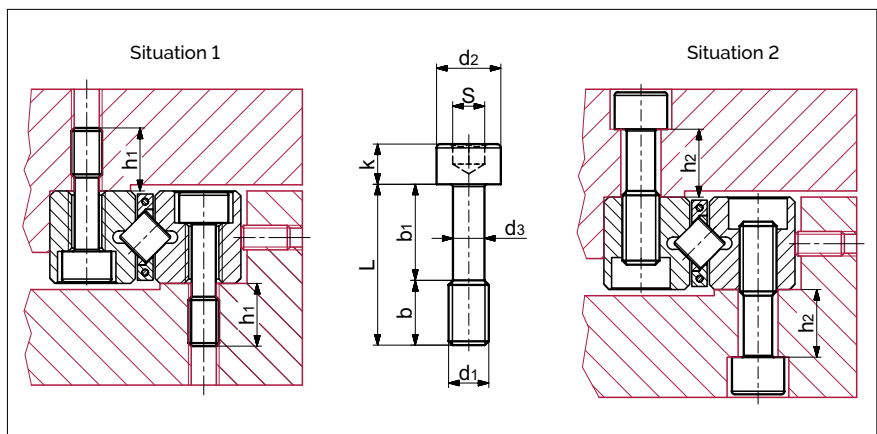

| Type | Size | L | b | b ₁ | d ₁ | d ₂ | d ₃ | k | s | Max. tightening torque in Ncm* | Compatible with guideways of size (Situation 1) | Compatible with guideways of size (Situation 2) |
|------|------|----|----|----------------|----------------|----------------|----------------|----|----|--------------------------------|---|---|
| GD | 3 | 12 | 5 | 7 | M3 | 5 | 23 | 3 | 25 | 94 | R 3 & RD 2 | R 2 & RD 1 |
| | 4 | 16 | 7 | 9 | M4 | 6.5 | 3 | 4 | 3 | 221 | RD 3 | R 3 & RD 2 |
| | 6 | 20 | 8 | 12 | M5 | 8 | 3.9 | 5 | 4 | 463 | R 6 & RD 6 | RD 3 |
| | 9 | 30 | 12 | 18 | M6 | 8.5 | 4.6 | 6 | 5 | 762 | R 9 & RD 9 | R 6 & RD 6 |
| | 12 | 40 | 17 | 23 | M8 | 11.3 | 6.25 | 8 | 6 | 1838 | R 12 & RD 12 | R 9 & RD 9 |
| | 15 | 45 | 16 | 29 | M10 | 13.9 | 7.9 | 10 | 8 | 3674 | - | R 12 & RD 12 |

* Tightening torques apply for materials with a tensile strength of > 360N/mm²

5 Linear guideways

5.2 Type RN



Type RN

The type RN linear guideway is the logical optimised version of the R guideway. It has identical installed dimensions, but due to the optimized contact surfaces of the guideway tracks is, however, higher performing. The reduced gap width between the guide rails also provides better protection against contaminants.

Benchmark data

Track and surface quality

- Finely ground supporting and/or locating surfaces and tracks (90° V-profile)

Materials (standard)

- Rails made of through hardened tool steel 1.2842, hardness 58 – 62 HRC
- For non-corrosive guideways tool steel 1.4034 and 1.4112 is used
- Rolling element made of through hardened roller bearing steel, hardness 58 – 64 HRC

Rolling element

- Roller

Speed

- 1 m/s

Acceleration

- 50 m/s²
- 300 m/s² with cage control

Accuracy

- RN linear guideways are available in three quality classes (see chapter 9)

Operating temperatures

- -40° C to +80° C

5 Linear guideways

Dimensions and load capacities of type RN

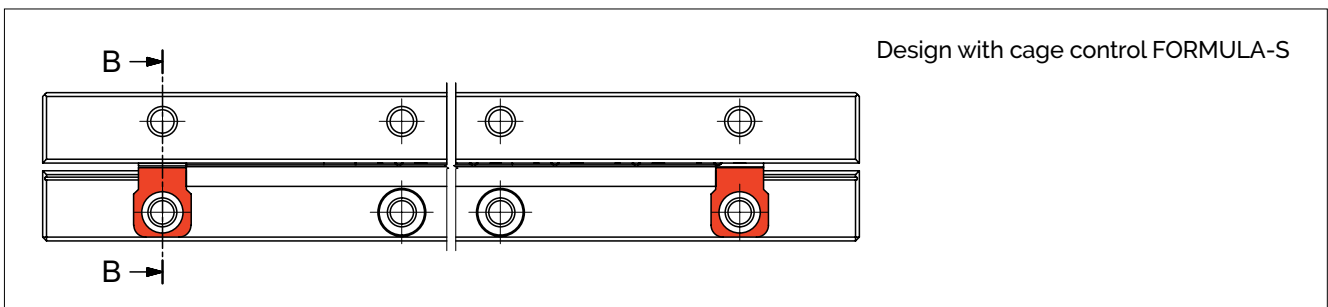
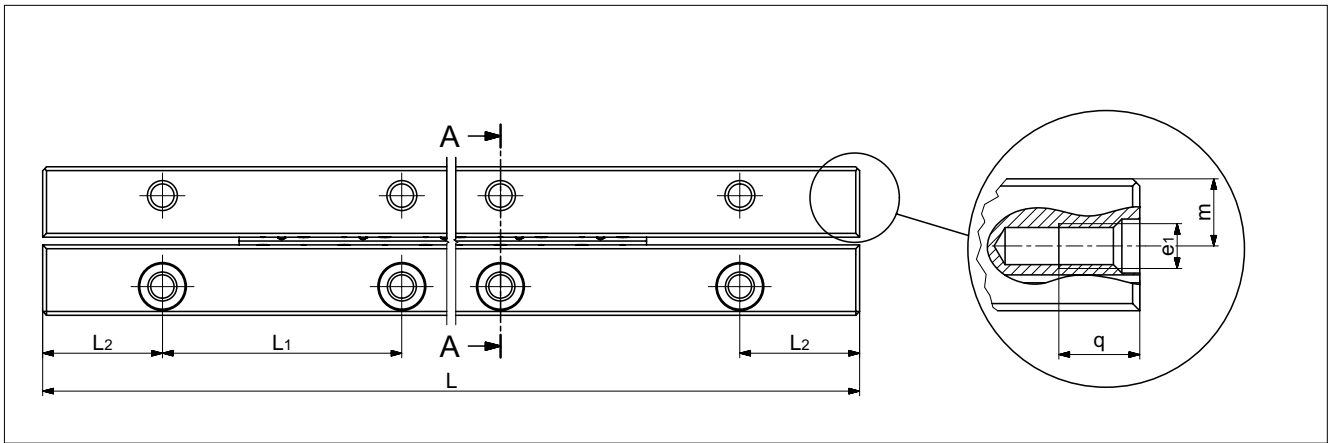

| Type | Size | L in mm ⁽¹⁾ | Weight in g | A | B/B ₂ | Dw | J | L ₁ | L ₂ | N | d | e | e ₁ | f | g | m | q | s | Options (see chapter 7) | Accessories ⁽³⁾ |
|------|------|------------------------|-------------|----|------------------|-----|------|----------------|----------------|-----|-----|----|----------------|-----|-----|-----|---|------|---|--|
| | | | | mm | | | | | | | | | | | | | | | | |
| RN | 3 | 50 | 24 | 18 | 8 | 3 | 8.7 | 25 | 12.5 | 3.5 | 6 | M4 | M3 | 3.3 | 4.8 | 4.8 | 7 | 0.85 | SQ SSQ RF EG ZG HA DU DR KS | Cage: - KBN 3 - KBS 3 End screw: - GAN 3 Fastening screw: - GD 3 - GD 4 |
| | | 75 | 35 | | | | | | | | | | | | | | | | | |
| | | 100 | 47 | | | | | | | | | | | | | | | | | |
| | | 125 | 59 | | | | | | | | | | | | | | | | | |
| | | 150 | 71 | | | | | | | | | | | | | | | | | |
| | | 175 | 82 | | | | | | | | | | | | | | | | | |
| | | 200 | 94 | | | | | | | | | | | | | | | | | |
| | | 225 | 106 | | | | | | | | | | | | | | | | | |
| | | 250 | 118 | | | | | | | | | | | | | | | | | |
| | | 275 | 129 | | | | | | | | | | | | | | | | | |
| 300 | 141 | | | | | | | | | | | | | | | | | | | |
| RN | 4 | 80 | 62 | 22 | 11 | 4.5 | 10.5 | 40 | 20 | 4.5 | 8 | M5 | M3 | 4.3 | 6.9 | 5.5 | 7 | 0.85 | SQ SSQ RF EG ZG HA DU DR KS | Cage: - KBN 4 - KBS 4 End screw: - GAN 4 Fastening screw: - GD 4 - GD 6 |
| | | 120 | 93 | | | | | | | | | | | | | | | | | |
| | | 160 | 124 | | | | | | | | | | | | | | | | | |
| | | 200 | 155 | | | | | | | | | | | | | | | | | |
| | | 240 | 186 | | | | | | | | | | | | | | | | | |
| | | 280 | 217 | | | | | | | | | | | | | | | | | |
| | | 320 | 248 | | | | | | | | | | | | | | | | | |
| | | 360 | 279 | | | | | | | | | | | | | | | | | |
| | | 400 | 310 | | | | | | | | | | | | | | | | | |
| RN | 6 | 100 | 151 | 31 | 15 | 6.5 | 14.8 | 50 | 25 | 6 | 9.5 | M6 | M5 | 5.2 | 9.8 | 7.5 | 9 | 0.85 | SQ SSQ RF EG ZG HA DU DR KS | Cage: - KBN 6 - KBS 6 End screw: - GA 6 Fastening screw: - GD 6 - GD 9 |
| | | 150 | 226 | | | | | | | | | | | | | | | | | |
| | | 200 | 301 | | | | | | | | | | | | | | | | | |
| | | 250 | 377 | | | | | | | | | | | | | | | | | |
| | | 300 | 452 | | | | | | | | | | | | | | | | | |
| | | 350 | 527 | | | | | | | | | | | | | | | | | |
| | | 400 | 603 | | | | | | | | | | | | | | | | | |
| | | 450 | 678 | | | | | | | | | | | | | | | | | |
| 500 | 753 | | | | | | | | | | | | | | | | | | | |

⁽¹⁾ The lengths listed are standard; other lengths are of course available. The maximum lengths are listed on page 34.

⁽²⁾ B designates the width of a guideway. B₂ designates the width over both guideways.

⁽³⁾ Select accessories as follows: Cage type: page 35, end and fixing screws: page 36

5 Linear guideways

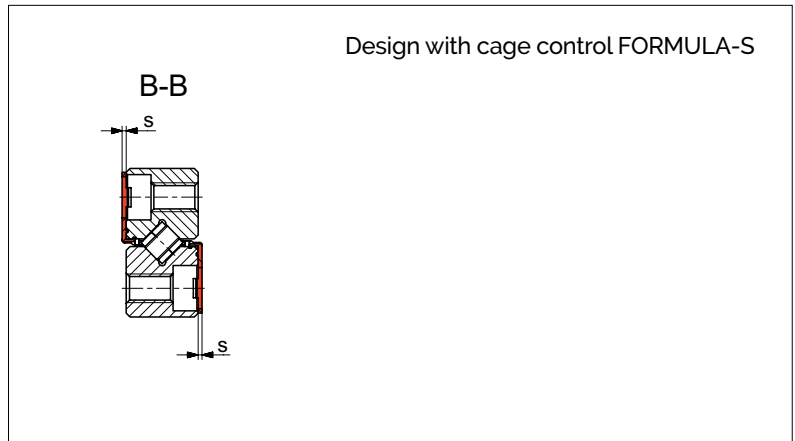
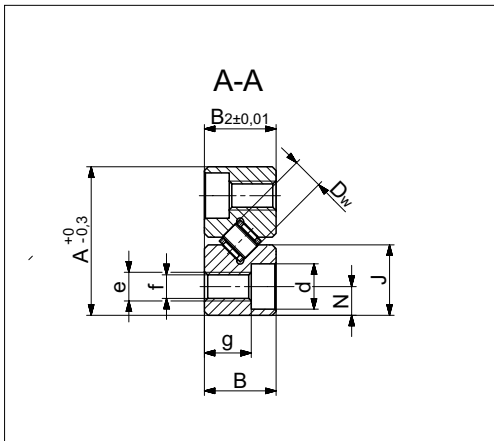

| Type | Size | L in mm ⁽¹⁾ | Weight in g | A | B/B ₂ | Dw | J | L ₁ | L ₂ | N | d | e | e ₁ | f | g | m | q | s | Options (see chapter 7) | Accessories ⁽³⁾ |
|------|------|------------------------|-------------|----|------------------|----|-----|----------------|----------------|----|------|-----|----------------|-----|------|------|----|---|---|--|
| | | | | mm | | | | | | | | | | | | | | | | |
| RN | 9 | 200 | 659 | 44 | 22 | 9 | 211 | 100 | 50 | 9 | 10.5 | M8 | M6 | 6.8 | 15.8 | 11.5 | 9 | - | SQ SSQ RF EG ZG HA DU | Cage: - KBN 9 End screw: - GA 9 Fastening screw: - GD 9 - GD 12 |
| | | 300 | 988 | | | | | | | | | | | | | | | | | |
| | | 400 | 1318 | | | | | | | | | | | | | | | | | |
| | | 500 | 1647 | | | | | | | | | | | | | | | | | |
| | | 600 | 1976 | | | | | | | | | | | | | | | | | |
| | | 700 | 2306 | | | | | | | | | | | | | | | | | |
| 800 | 2635 | | | | | | | | | | | | | | | | | | | |
| RN | 12 | 200 | 1086 | 58 | 28 | 12 | 276 | 100 | 50 | 12 | 13.5 | M10 | M8 | 8.5 | 19.8 | 15 | 12 | - | SQ SSQ RF EG ZG HA DU | Cage: - KBN 12 End screw: - GA 12 Fastening screw: - GD 12 - GD 15 |
| | | 300 | 1628 | | | | | | | | | | | | | | | | | |
| | | 400 | 2171 | | | | | | | | | | | | | | | | | |
| | | 500 | 2714 | | | | | | | | | | | | | | | | | |
| | | 600 | 3257 | | | | | | | | | | | | | | | | | |
| | | 700 | 3800 | | | | | | | | | | | | | | | | | |
| | | 800 | 4342 | | | | | | | | | | | | | | | | | |
| | | 900 | 4885 | | | | | | | | | | | | | | | | | |
| 1000 | 5428 | | | | | | | | | | | | | | | | | | | |

⁽¹⁾ The lengths listed are standard; other lengths are of course available. The maximum lengths are listed on page 34.

⁽²⁾ B designates the width of a guideway. B₂ designates the width over both guideways.

⁽³⁾ Select accessories as follows: Cage type: page 35, end and fixing screws: page 36

5 Linear guideways

Maximum lengths for type RN

| Type / Size | Quality class | Max. lengths in standard material (in mm) | Max lengths in non-corrosive material (in mm) |
|-------------|---------------|--|--|
| RN 3 | NQ | 800 | 600 |
| | SQ | | |
| | SSQ | 600 | |
| RN 4 | NQ | 900 | 900 |
| | SQ | 600 | 600 |
| | SSQ | | |
| RN 6 | NQ | 1'500 | 1'400 |
| | SQ | | 1'200 |
| | SSQ | 1'200 | 900 |
| RN 9 | NQ | 3'000 | 3'000 |
| | SQ | | |
| | SSQ | | |
| RN 12 | NQ | 3'000 | 3'000 |
| | SQ | | |
| | SSQ | | |

Rail chamfer

The detail of the rail chamfer is shown in the chart below. Please note that the part number and company logo are marked opposite to the datum and supporting surfaces.

| Type / Size | Rail chamfer of reference edges in mm |
|-------------|---------------------------------------|
| RN 3 | 0.6 x 45° |
| RN 4 | 0.6 x 45° |
| RN 6 | 0.8 x 45° |
| RN 9 | 0.8 x 45° |
| RN 12 | 1.0 x 45° |

5 Linear guideways

Accessories for type RN

Roller cage type KBN

Compatible with:
Linear guideway type RN
Sizes 3 to 12

Design:
Rollers fixed in place

Installation method:
For normal application and certain
overrunning cage applications

Material:
POM (Vacuum-compatible up
to 10^{-7} mbar)

Option:
Corrosion-resistant rollers

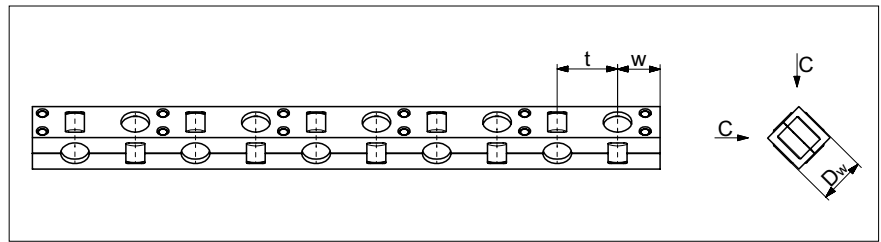

| Type | Size | Dw | t | w | C ₁₀₀ per roller in N | C ₅₀ per roller in N | Max. length in mm |
|------|------|-----|-----|-------------|----------------------------------|---------------------------------|-------------------|
| KBN | 3 | 3 | 5 | approx. 3.5 | 410 | 504.3 | 900 |
| | 4 | 4.5 | 6.5 | approx. 4 | 850 | 1045.5 | 900 |
| | 6 | 6.5 | 8.5 | approx. 5 | 1'800 | 2214.0 | 1'500 |
| | 9 | 9 | 12 | approx. 7.5 | 3'900 | 4797.0 | 1'500 |
| | 12 | 12 | 15 | approx. 9 | 6'500 | 7995.0 | 1'500 |

Type KBS roller cage for the cage control FORMULA-S

Detailed information on
FORMULA-S is listed under chapter 7.8.

Compatible with:
Linear guideway type RN
Sizes 3 to 6

Design:
Rollers fixed in place
With integral pinion

Installation method:
For normal application and certain
overrunning cage applications

Material:
POM (Vacuum-compatible up
to 10^{-7} mbar)

Option:
Corrosion-resistant rollers

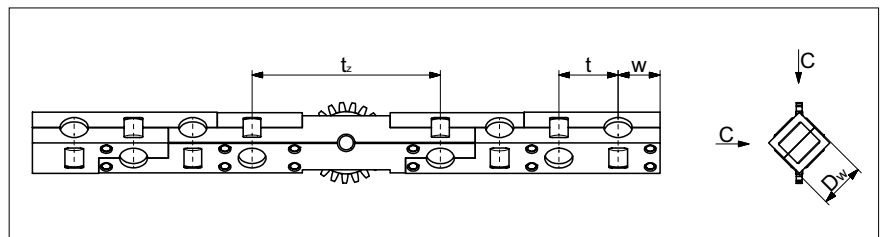

| Type | Size | Dw | t | tz | w | C ⁽¹⁾ ₁₀₀ per roller in N | C ⁽¹⁾ ₅₀ per roller in N | Max. length in mm |
|------|------|-----|-----|----|-------------|---|--|-------------------|
| KBS | 3 | 3 | 5 | 18 | approx. 3.5 | 410 | 504.3 | 900 |
| | 4 | 4.5 | 6.5 | 23 | approx. 4 | 850 | 1045.5 | 900 |
| | 6 | 6.5 | 8.5 | 27 | approx. 5 | 1'800 | 2214.0 | 1'500 |

⁽¹⁾ The loading capacity C already includes the hardness factor f_H as set out in chapter 12.3

5 Linear guideways

End screws type GAN

Compatible with:
Linear guideway RN 3 and RN 4

Installation method:
For horizontal installation

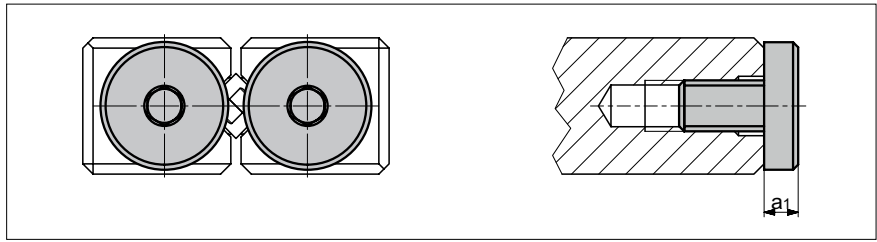

| Size | GAN 3 | GAN 4 |
|-------|-------|-------|
| a_1 | 2 | 2 |

End screws type GA

Compatible with:
Linear guideway RN 6 to RN 12

Installation method:
For horizontal installation

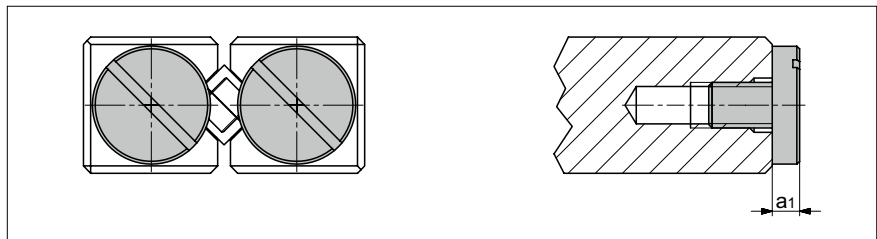

| Size | GA 6 | GA 9 | GA 12 |
|-------|------|------|-------|
| a_1 | 3 | 3 | 3 |

Fastening screws with thin shaft type GD 3 to GD 15

Special feature:
To compensate for differences in hole pitches

Compatible with:
Linear guideway type RN 3 to RN 12

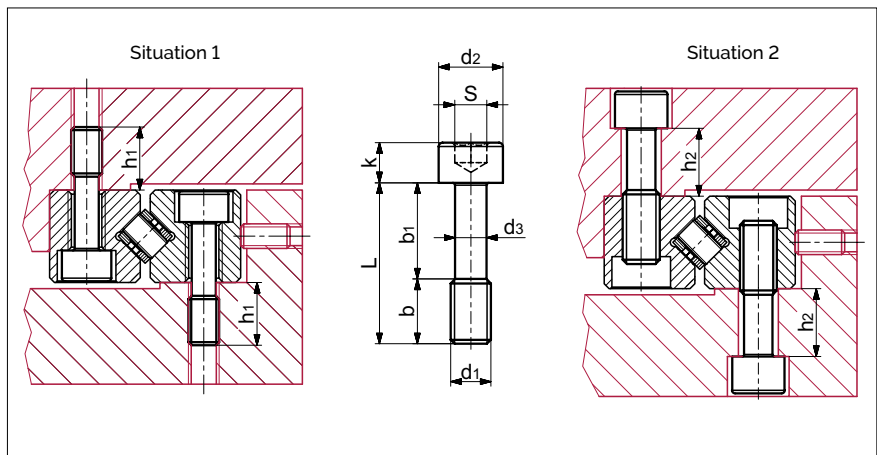

| Type | Size | L | b | b ₁ | d ₁ | d ₂ | d ₃ | k | s | Max. tightening torque in Ncm ⁽¹⁾ | Compatible with linear guideways of size (Situation 1) | Compatible with linear guideways of size (Situation 2) |
|------|------|----|----|----------------|----------------|----------------|----------------|----|-----|--|--|--|
| GD | 3 | 12 | 5 | 7 | M3 | 5 | 2.3 | 3 | 2.5 | 94 | RN 3 | - |
| | 4 | 16 | 7 | 9 | M4 | 6.5 | 3 | 4 | 3 | 221 | RN 4 | RN 3 |
| | 6 | 20 | 8 | 12 | M5 | 8 | 3.9 | 5 | 4 | 463 | RN 6 | RN 4 |
| | 9 | 30 | 12 | 18 | M6 | 8.5 | 4.6 | 6 | 5 | 762 | RN 9 | RN 6 |
| | 12 | 40 | 17 | 23 | M8 | 11.3 | 6.25 | 8 | 6 | 1838 | RN 12 | RN 9 |
| | 15 | 45 | 16 | 29 | M10 | 13.9 | 7.9 | 10 | 8 | 3674 | - | RN 12 |

⁽¹⁾ Tightening torques apply for materials with a tensile strength of > 360N/mm²

5 Linear guideways

5.3 Type RNG



Type RNG

Like type RN, the type RNG linear guideway is based on the type R linear guideway. Like type RN, it has larger contact surfaces for the guideway tracks, which means its performance is significantly enhanced. Compared with types R and RN its cross-section is, however, smaller, which means that it represents a cost-effective solution without compromise.

Benchmark data

Track and surface quality

- Finely ground supporting and/or locating surfaces and tracks (90° V-profile)

Materials (standard)

- Rails from through hardened tool steel 1.2842, hardness 58 - 62 HRC
- For non-corrosive guideways tool steel 1.4034 and 1.4112 is used
- Rolling element made of through hardened roller bearing steel, hardness 58 - 64 HRC

Rolling element

- Roller

Speed

- 1 m/s

Acceleration

- 50 m/s²
- 300 m/s² with cage control

Accuracy

- RNG linear guideways are available in three quality classes (see chapter 9)

Operating temperatures

- -40° C to +80° C

5 Linear guideways

Dimensions and load capacities of type RNG

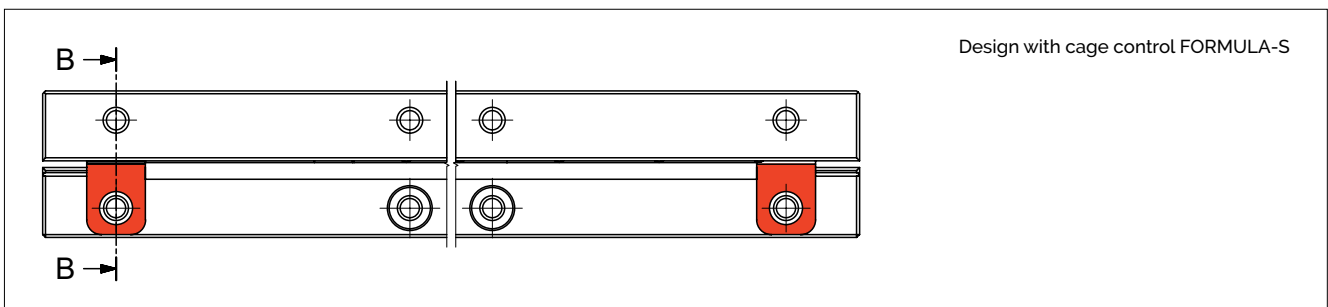
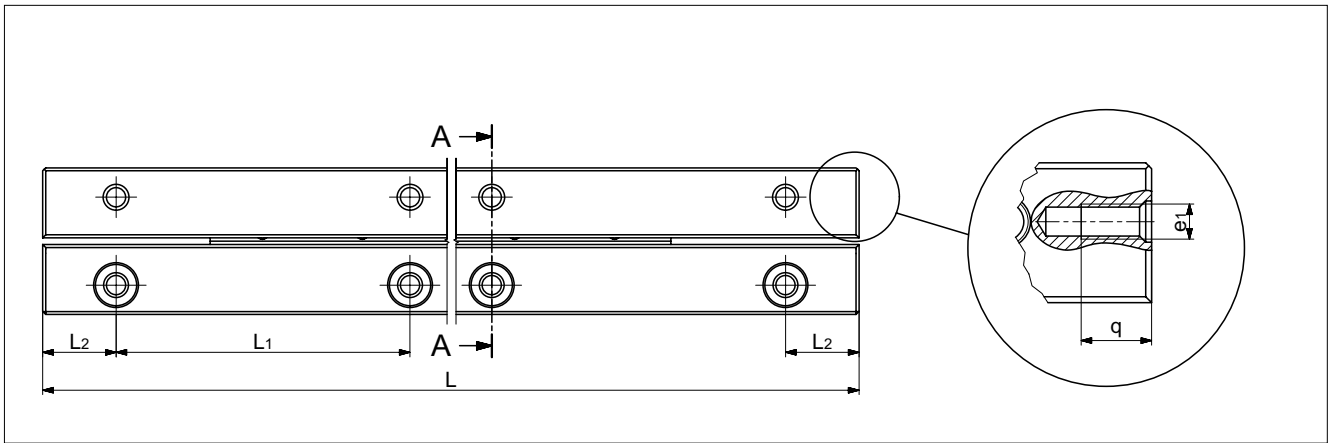

| Type | Size | L in mm ⁽¹⁾ | Weight in g | A | B/B ₂ ⁽²⁾ | Dw | J | L ₁ | L ₂ | N | d | e | e ₁ | f | g | m | q | u | s | Options (see chapter 7) | Accessories ⁽³⁾ |
|------|------|------------------------|-------------|----|---------------------------------|-----|----|----------------|----------------|----|-----|----|----------------|------|-----|-----|---|---|------|---|---|
| | | | | mm | | | | | | | | | | | | | | | | | |
| RNG | 4 | 50 | 27 | 19 | 9 | 4.5 | 9 | 25 | 125 | 35 | 5.5 | M3 | M3 | 2.65 | 6.3 | 3.5 | 6 | - | 0.85 | SQ SSQ RF EG ZG HA DU DR KS | Cage: - KBN 4 - KBS 4 End pieces: - GBN 4 - GCN 4 - GCN-A 4 Fastening screw: - GDN 4 - GDN 6 |
| | | 75 | 41 | | | | | | | | | | | | | | | | | | |
| | | 100 | 55 | | | | | | | | | | | | | | | | | | |
| | | 125 | 69 | | | | | | | | | | | | | | | | | | |
| | | 150 | 83 | | | | | | | | | | | | | | | | | | |
| | | 175 | 97 | | | | | | | | | | | | | | | | | | |
| | | 200 | 111 | | | | | | | | | | | | | | | | | | |
| | | 225 | 125 | | | | | | | | | | | | | | | | | | |
| | | 250 | 139 | | | | | | | | | | | | | | | | | | |
| | | 275 | 153 | | | | | | | | | | | | | | | | | | |
| 300 | 167 | | | | | | | | | | | | | | | | | | | | |
| RNG | 6 | 100 | 92 | 25 | 12 | 6.5 | 12 | 25 | 125 | 5 | 7 | M4 | M3 | 3.3 | 8.8 | 5 | 6 | - | 0.85 | SQ SSQ RF EG ZG HA DU DR KS | Cage: - KBN 6 - KBS 6 End pieces: - GBN 6 - GCN 6 - GCN-A 6 Fastening screw: - GDN 6 - GDN 9 |
| | | 150 | 138 | | | | | | | | | | | | | | | | | | |
| | | 200 | 184 | | | | | | | | | | | | | | | | | | |
| | | 250 | 230 | | | | | | | | | | | | | | | | | | |
| | | 300 | 276 | | | | | | | | | | | | | | | | | | |
| | | 350 | 322 | | | | | | | | | | | | | | | | | | |
| | | 400 | 368 | | | | | | | | | | | | | | | | | | |

⁽¹⁾ The lengths listed are standard; other lengths are of course available. The maximum lengths are listed on page 40.

⁽²⁾ B designates the width of a guideway. B₂ designates the width over both guideways.

⁽³⁾ Select accessories as follows: Cage type: page 41, end pieces: pages 42 and 43, fixing screws: page 43

5 Linear guideways

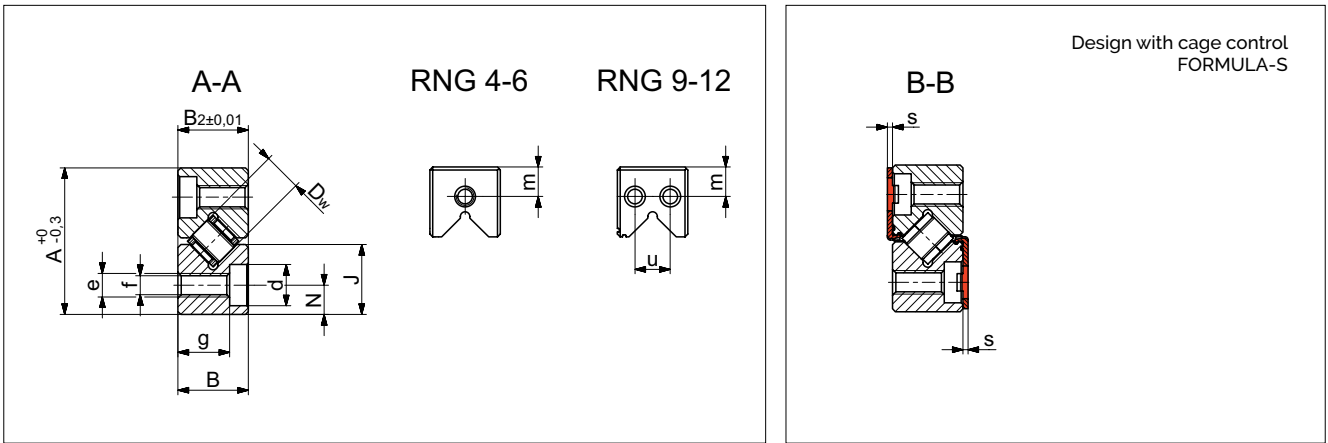

| Type | Size | L in mm ⁽¹⁾ | Weight in g | A | B/B ₂ ⁽²⁾ | Dw | J | L ₁ | L ₂ | N | d | e | e ₁ | f | g | m | q | u | s | Options (see chapter 7) | Accessories ⁽³⁾ |
|------|------|------------------------|-------------|----|---------------------------------|----|----|----------------|----------------|---|-----|----|----------------|-----|------|----|-----|----|------|---|--|
| | | | | mm | | | | | | | | | | | | | | | | | |
| RNG | 9 | 100 | 150 | 33 | 16 | 9 | 16 | 25 | 12.5 | 6 | 8.5 | M5 | M3 | 4.4 | 11.8 | 8 | 6 | 8 | 0.85 | SQ SSQ RF EG ZG HA DU DR KS | Cage: - KBN 9 - KBS 9 End pieces: - GBN 9 - GCN 9 - GCN-A 9 Fastening screw: - GDN 9 |
| | | 150 | 230 | | | | | | | | | | | | | | | | | | |
| | | 200 | 310 | | | | | | | | | | | | | | | | | | |
| | | 250 | 390 | | | | | | | | | | | | | | | | | | |
| | | 300 | 470 | | | | | | | | | | | | | | | | | | |
| | | 350 | 550 | | | | | | | | | | | | | | | | | | |
| | | 400 | 630 | | | | | | | | | | | | | | | | | | |
| | | 450 | 710 | | | | | | | | | | | | | | | | | | |
| 500 | 790 | | | | | | | | | | | | | | | | | | | | |
| RNG | 12 | 200 | 600 | 45 | 22 | 12 | 22 | 50 | 25 | 8 | 12 | M8 | M5 | 6.8 | 15.8 | 11 | 7.5 | 10 | - | SQ SSQ RF EG ZG HA DU | Cage: - KBN 12 End pieces: - GBN 12 - GCN 12 - GCN-A 12 Fastening screw: - GDN 12 - GDN 15 |
| | | 300 | 905 | | | | | | | | | | | | | | | | | | |
| | | 400 | 1207 | | | | | | | | | | | | | | | | | | |
| | | 500 | 1508 | | | | | | | | | | | | | | | | | | |
| | | 600 | 1810 | | | | | | | | | | | | | | | | | | |
| | | 700 | 2125 | | | | | | | | | | | | | | | | | | |
| | | 800 | 2430 | | | | | | | | | | | | | | | | | | |
| | | 900 | 2734 | | | | | | | | | | | | | | | | | | |
| 1000 | 3038 | | | | | | | | | | | | | | | | | | | | |

⁽¹⁾ The lengths listed are standard; other lengths are of course available. The maximum lengths are listed on page 40.

⁽²⁾ B designates the width of a guideway. B₂ designates the width over both guideways.

⁽³⁾ Select accessories as follows: Cage type: page 41, end pieces: pages 42 and 43, fixing screws: page 43

5 Linear guideways

Maximum lengths for type RNG

| Type / Size | Quality class | Max. lengths in standard material (in mm) | Max lengths in non-corrosive material (in mm) |
|-------------|---------------|--|--|
| RNG4 | NQ | 900 | 900 |
| | SQ | | |
| | SSQ | 600 | 600 |
| RNG6 | NQ | 1'500 | 1'400 |
| | SQ | | 1'200 |
| | SSQ | 1'200 | 900 |
| RNG9 | NQ | 3'000 | 3'000 |
| | SQ | | |
| | SSQ | | |
| RNG12 | NQ | 3'000 | 3'000 |
| | SQ | | |
| | SSQ | | |

Rail chamfer

The detail of the rail chamfer is shown in the chart below. Please note that the part number and company logo are marked opposite to the datum and supporting surfaces.

| Type / Size | Rail chamfer of reference edges in mm |
|-------------|---------------------------------------|
| RNG 4 | 0.4 x 45° |
| RNG 6 | 0.5 x 45° |
| RNG 9 | 0.8 x 45° |
| RN 12 | 0.8 x 45° |

5 Linear guideways

Type RNG accessories

Roller cage type KBN

Compatible with:
Type RNG linear guideway
Sizes 4 to 12

Design:
Rollers fixed in place

Installation method:
For normal application and certain
overrunning cage applications

Material:
POM (Vacuum-compatible up to 10^{-7}
mbar)

Option:
Corrosion-resistant rollers

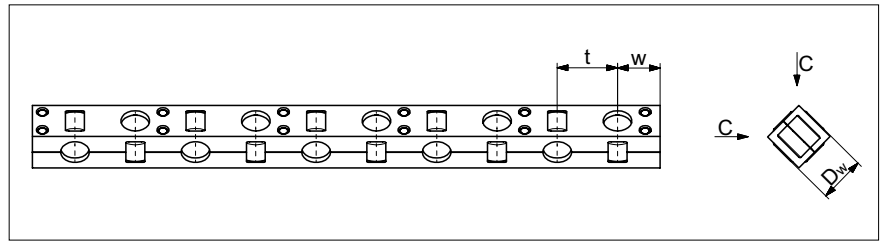

| Type | Size | Dw | t | w | C ₁₀₀ per roller in N | C ₅₀ per roller in N | Max. length in mm |
|------|------|-----|-----|-------------|----------------------------------|---------------------------------|-------------------|
| KBN | 4 | 4.5 | 6.5 | approx. 4 | 850 | 1045.5 | 900 |
| | 6 | 6.5 | 8.5 | approx. 5 | 1'800 | 2214.0 | 1'500 |
| | 9 | 9 | 12 | approx. 7.5 | 3'900 | 4797.0 | 1'500 |
| | 12 | 12 | 15 | approx. 9 | 6'500 | 7995.0 | 1'500 |

Type KBS roller cage for the cage control FORMULA-S

Detailed information on
FORMULA-S is listed under chapter 7.8.

Compatible with:
Type RNG linear guideway
Sizes 4 to 9

Design:
Rollers fixed in place
With integral pinion

Installation method:
For normal application and certain
overrunning cage applications

Material:
POM (Vacuum-compatible up to 10^{-7}
mbar)

Option:
Corrosion-resistant rollers

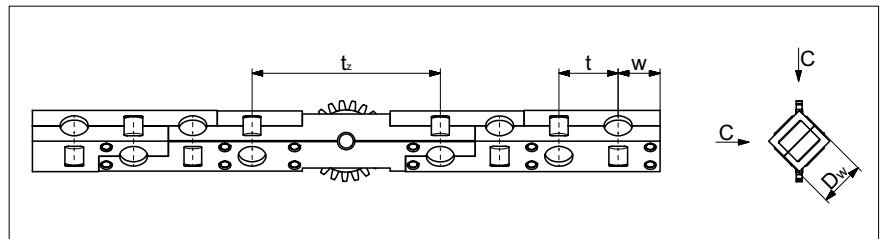

| Type | Size | Dw | t | tz | w | C ₁₀₀ per roller in N | C ₅₀ pro Rolle in N | Max. length in mm |
|------|------|-----|-----|----|-------------|----------------------------------|--------------------------------|-------------------|
| KBS | 4 | 4.5 | 6.5 | 23 | approx. 4 | 850 | 1045.5 | 900 |
| | 6 | 6.5 | 8.5 | 27 | approx. 5 | 1'800 | 2214.0 | 1'500 |
| | 9 | 9 | 12 | 40 | approx. 7.5 | 3'900 | 4797.0 | 1'500 |

5 Linear guideways

End piece type GBN 4 and GBN 6

Compatible with:
Linear guideway RNG 4 and RNG 6

Installation method:
No restrictions

Scope of supply:
Including end screws

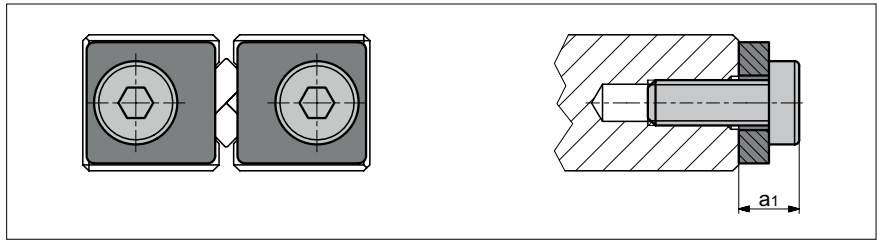

| Size | GBN 4 | GBN 6 |
|----------------|-------|-------|
| a ₁ | 4 | 4 |

End piece type GBN 9 and GBN 12

Compatible with:
Linear guideway RNG 9 and RNG 12

Installation method:
No restrictions

Scope of supply:
Including end screws

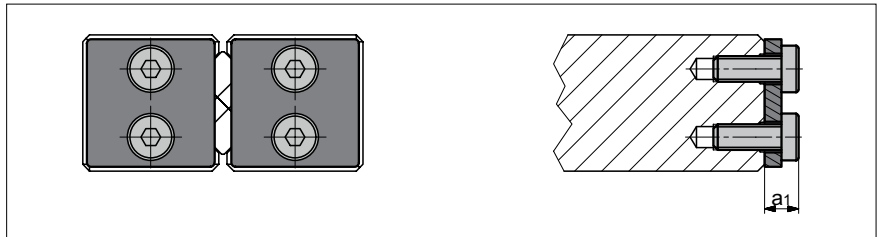

| Size | GBN 9 | GBN 12 |
|----------------|-------|--------|
| a ₁ | 4 | 85 |

End

piece type GCN 4 and GCN 6

Special feature:
For overrunning cage

Compatible with:
Linear guideway RNG 4 and RNG 6

Installation method:
No restrictions

Scope of supply:
Including end screws

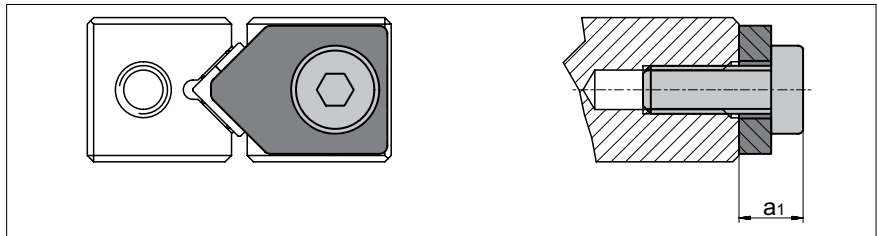

| Size | GCN 4 | GCN 6 |
|----------------|-------|-------|
| a ₁ | 4 | 4 |

End piece type GCN 9 and GCN 12

Special feature:
For overrunning cage

Compatible with:
Linear guideway RNG 9 and RNG 12

Installation method:
No restrictions

Scope of supply:
Including end screws

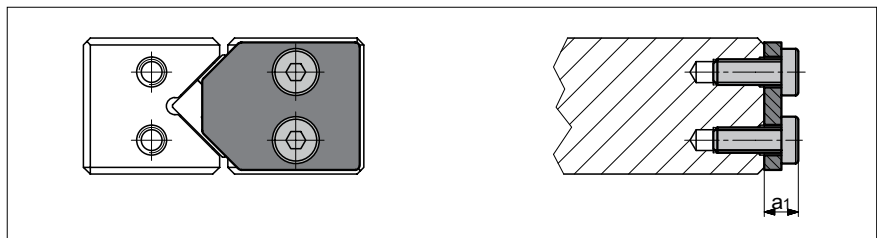

| Size | GCN 9 | GCN 12 |
|----------------|-------|--------|
| a ₁ | 4 | 85 |

5 Linear guideways

End piece type GCN-A 4 and GCN-A 6

Special feature:
With wipers made of plastic

Compatible with:
Linear guideway RNG 4 and RNG 6

Installation method:
No restrictions

Scope of supply:
Including end screws

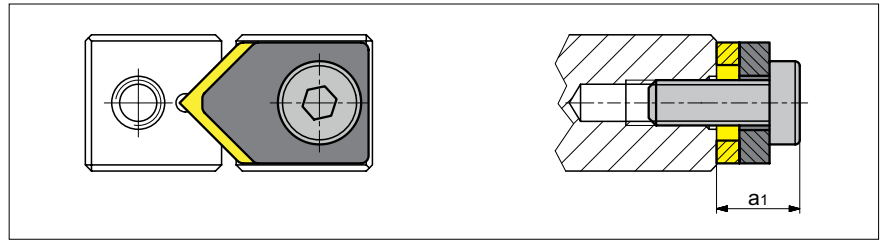

| Size | GCN-A 4 | GCN-A 6 |
|----------------|---------|---------|
| a ₁ | 5.5 | 5.5 |

End piece type GCN-A 9 and GCN-A 12

Special feature:
With wipers made of plastic

Compatible with:
Linear guideway RNG 9 and RNG 12

Installation method:
No restrictions

Scope of supply:
Including end screws

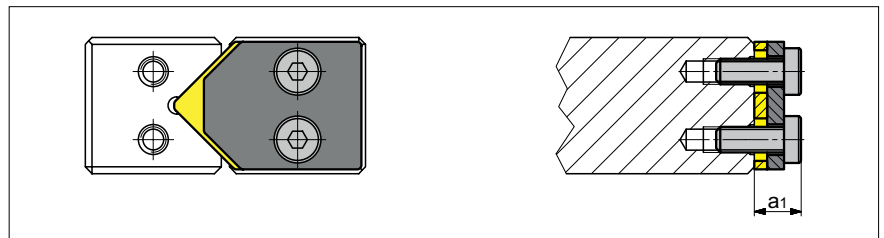

| Size | GCN-A 9 | GCN-A 12 |
|----------------|---------|----------|
| a ₁ | 5.5 | 10 |

Fastening screws with thin shaft type GDN 4 to GDN 15

Special feature:
To even out differences in the hole spacings

Compatible with:
Linear guideway type RNG 4 to RNG 12

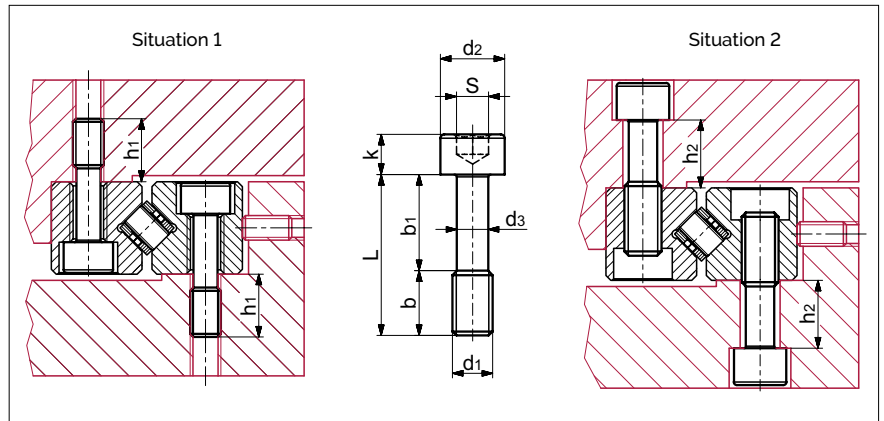

| Type | Size | L | b | b ₁ | d ₁ | d ₂ | d ₃ | k | s | Max. tightening torque in Ncm ⁽¹⁾ | Compatible with linear guideways of size (Situation 1) | Compatible with linear guideways of size (Situation 2) |
|------|------|----|----|----------------|----------------|----------------|----------------|-----|-----|--|--|--|
| GDN | 4 | 12 | 5 | 7 | M2.5 | 4.5 | 1.85 | 2.5 | 2 | 54 | RNG 4 | - |
| | 6 | 16 | 5 | 11 | M3 | 5.5 | 2.3 | 3 | 2.5 | 94 | RNG 6 | RNG 4 |
| | 9 | 25 | 11 | 14 | M4 | 7 | 3 | 4 | 3 | 221 | RNG 9 | RNG 6 |
| | 12 | 30 | 12 | 18 | M6 | 10 | 4.6 | 6 | 5 | 762 | RNG 12 | - |
| | 15 | 40 | 17 | 23 | M8 | 13 | 6.25 | 8 | 6 | 1838 | - | RNG 12 |

⁽¹⁾ Tightening torques apply for materials with a tensile strength of > 360N/mm²

5 Linear guideways

5.4 Type N/O



Type N/O

The type N/O linear guideways are equipped with needle cages and are particularly suitable for applications involving high loads. SCHNEEBERGER N/O bearings have a lower moving resistance due to our composite cage.

Benchmark data

Track and surface quality

- Finely ground supporting and/or locating surfaces and tracks (90° V-profile)

Materials (standard)

- Rails from through hardened tool steel 1.2842, hardness 58 – 62 HRC
- For non-corrosive guideways tool steel 1.4034 and 1.4112 is used
- Rolling element made of through hardened roller bearing steel, hardness 58 – 64 HRC

Rolling element

- Needle

Speed

- 1 m/s

Acceleration

- 50 m/s²
- 200 m/s² with cage control

Accuracy

- Type N/O linear guideways are available in three quality classes (see chapter 9)

Operating temperatures

- -40° C to +80° C

5 Linear guideways

Dimensions and load capacities of type N/O

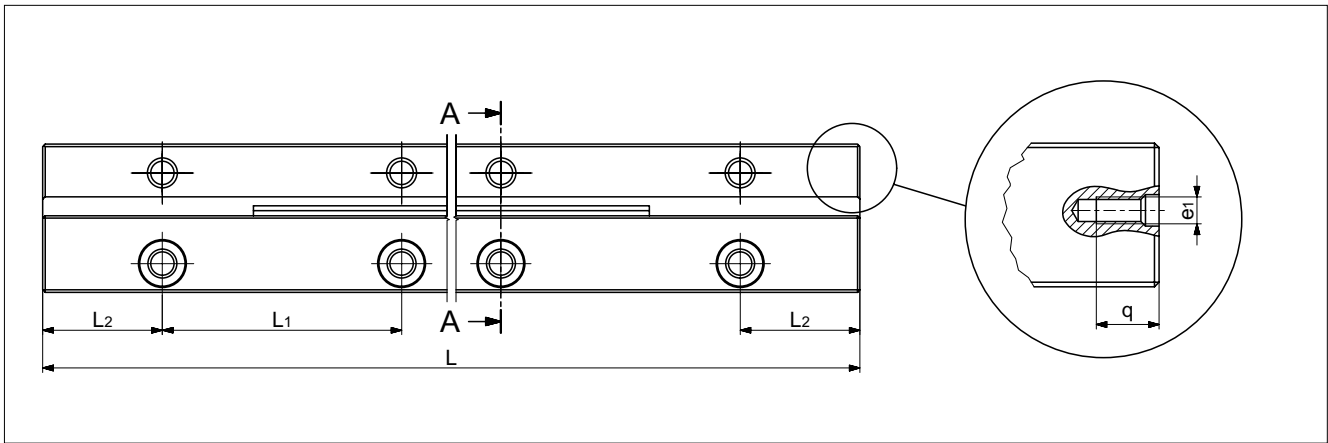

| Type | Size | L in mm ⁽¹⁾ | Weight in g | | A | B/ B ₂ ⁽²⁾ | Dw | F | J | J ₁ | L ₁ | L ₂ | N | d | e | e ₁ | f | g | m | m ₁ | q | u | u ₁ | Options (see chapter 7) | Accessories ⁽³⁾ |
|------|-------|------------------------|-------------|--------|----|-------------------------------------|----|----|----|----------------|----------------|----------------|----|------|-----|----------------|-----|------|-----|----------------|----|----|----------------|--|--|
| | | | Type N | Type O | mm | | | | | | | | | | | | | | | | | | | | |
| N/O | 62015 | 100 | 146 | 164 | 31 | 15 | 2 | 11 | 16 | 18 | 50 | 25 | 6 | 9.5 | M6 | M3 | 5.2 | 9.8 | 7.5 | 4.5 | 7 | 7 | 7 | SQ SSQ RF EG ZG HA DU KZST | Cage: - HW 10 End pieces: - GFN 62015 - GFO 62015 - GH 62015 - GH-A 62015 - GW 62015 - GW-A 62015 Fastening screw: - GD 6 - GD 9 |
| | | 150 | 219 | 246 | | | | | | | | | | | | | | | | | | | | | |
| | | 200 | 292 | 328 | | | | | | | | | | | | | | | | | | | | | |
| | | 250 | 365 | 410 | | | | | | | | | | | | | | | | | | | | | |
| | | 300 | 438 | 492 | | | | | | | | | | | | | | | | | | | | | |
| | | 350 | 511 | 574 | | | | | | | | | | | | | | | | | | | | | |
| | | 400 | 584 | 656 | | | | | | | | | | | | | | | | | | | | | |
| N/O | 92025 | 200 | 685 | 695 | 44 | 22 | 2 | 15 | 24 | 24.5 | 100 | 50 | 9 | 10.5 | M8 | M4 | 6.8 | 15.8 | 11 | 6 | 9 | 10 | 10 | SQ SSQ RF EG ZG HA DU KZST | Cage: - HW 15 - SHW 15 End pieces: - GFN 92025 - GFO 92025 - GH 92025 - GH-A 92025 - GW 92025 - GW-A 92025 Fastening screw: - GD 9 - GD 2025 |
| | | 300 | 1020 | 1030 | | | | | | | | | | | | | | | | | | | | | |
| | | 400 | 1360 | 1373 | | | | | | | | | | | | | | | | | | | | | |
| | | 500 | 1700 | 1717 | | | | | | | | | | | | | | | | | | | | | |
| | | 600 | 2025 | 2035 | | | | | | | | | | | | | | | | | | | | | |
| | | 700 | 2360 | 2370 | | | | | | | | | | | | | | | | | | | | | |
| | | 800 | 2697 | 2709 | | | | | | | | | | | | | | | | | | | | | |
| N/O | 2025 | 200 | 924 | 900 | 52 | 25 | 2 | 18 | 28 | 29 | 100 | 50 | 10 | 13.5 | M10 | M6 | 8.5 | 16.8 | 12 | 7 | 11 | 14 | 11 | SQ SSQ RF EG ZG HA Dut KZST | Cage: - SHW 15 End pieces: - GFN 2025 - GFO 2025 - GH 2025 - GH-A 2025 - GW 2025 - GW-A 2025 Fastening screw: - GD 2025 - GD 2035 |
| | | 300 | 1386 | 1350 | | | | | | | | | | | | | | | | | | | | | |
| | | 400 | 1848 | 1800 | | | | | | | | | | | | | | | | | | | | | |
| | | 500 | 2310 | 2250 | | | | | | | | | | | | | | | | | | | | | |
| | | 600 | 2772 | 2700 | | | | | | | | | | | | | | | | | | | | | |
| | | 700 | 3234 | 3150 | | | | | | | | | | | | | | | | | | | | | |
| | | 800 | 3696 | 3600 | | | | | | | | | | | | | | | | | | | | | |
| | | 900 | 4158 | 4050 | | | | | | | | | | | | | | | | | | | | | |
| | | 1000 | 4620 | 4500 | | | | | | | | | | | | | | | | | | | | | |
| | | 1100 | 5082 | 4950 | | | | | | | | | | | | | | | | | | | | | |
| | | 1200 | 5544 | 5400 | | | | | | | | | | | | | | | | | | | | | |
| 1400 | 6468 | 6300 | | | | | | | | | | | | | | | | | | | | | | | |
| 1600 | 7392 | 7200 | | | | | | | | | | | | | | | | | | | | | | | |

⁽¹⁾ The lengths listed are standard; other lengths are of course available. The maximum lengths are listed on page 48.

⁽²⁾ B designates the width of a guideway. B2 designates the width over both guideways.

⁽³⁾ Select accessories as follows: Cage type: page 49 and 50, end pieces: pages 51 and 52, fixing screws: page 52

5 Linear guideways

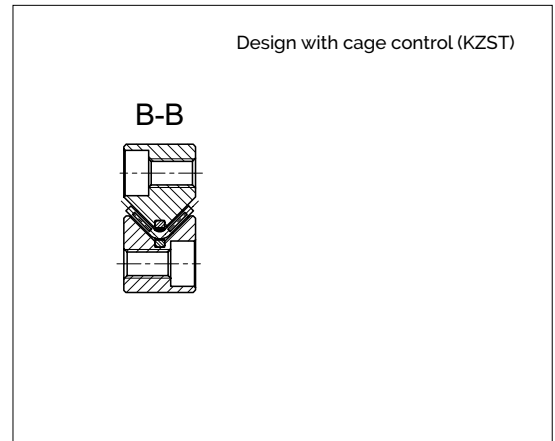
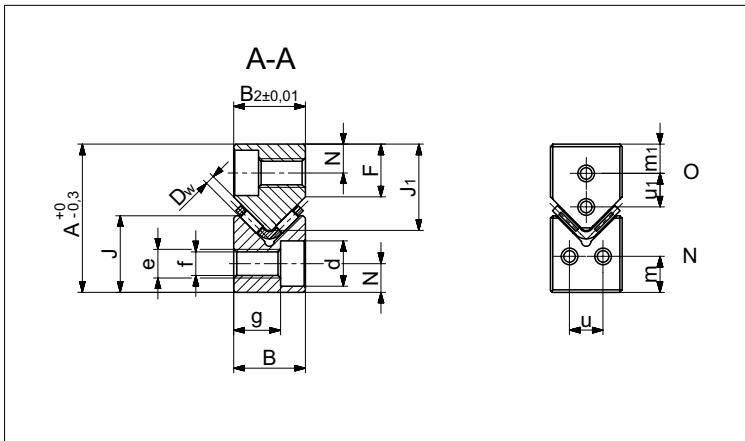

Design with cage control (KZST)

| Type | Size | L in mm ⁽¹⁾ | Weight in g | | A | B/ B ₂ ⁽²⁾ | Dw | F | J | J ₁ | L ₁ | L ₂ | N | d | e | e ₁ | f | g | m | m ₁ | q | u | u ₁ | Options (see chapter 7) | Accessories ⁽³⁾ |
|------|-------|------------------------|-------------|--------|----|-------------------------------------|-----|----|------|----------------|----------------|----------------|----|------|-----|----------------|------|------|----|----------------|----|----|----------------|---|---|
| | | | Type N | Type O | | | | | | | | | | | | | | | | | | | | | |
| N/O | 2535 | 300 | 1905 | 1995 | 62 | 30 | 2.5 | 22 | 34 | 35 | 100 | 50 | 12 | 16.5 | M12 | M6 | 10.5 | 19.8 | 15 | 8 | 11 | 18 | 12 | SQ SSQ RF EG ZG HA DU KZST | Cage: - HW 20 - SHW 20 End pieces: - GFN 2535 - GFO 2535 - GH 2535 - GH-A 2535 - GW 2535 - GW-A 2535 Fastening screw: - GD 2535 - GD 3035 |
| | | 400 | 2540 | 2660 | | | | | | | | | | | | | | | | | | | | | |
| | | 500 | 3175 | 3325 | | | | | | | | | | | | | | | | | | | | | |
| | | 600 | 3810 | 3990 | | | | | | | | | | | | | | | | | | | | | |
| | | 700 | 4445 | 4655 | | | | | | | | | | | | | | | | | | | | | |
| | | 800 | 5080 | 5320 | | | | | | | | | | | | | | | | | | | | | |
| | | 900 | 5715 | 5985 | | | | | | | | | | | | | | | | | | | | | |
| | | 1000 | 6350 | 6650 | | | | | | | | | | | | | | | | | | | | | |
| | | 1100 | 6985 | 7315 | | | | | | | | | | | | | | | | | | | | | |
| | | 1200 | 7620 | 7980 | | | | | | | | | | | | | | | | | | | | | |
| 1400 | 8890 | 9310 | | | | | | | | | | | | | | | | | | | | | | | |
| 1600 | 10160 | 10640 | | | | | | | | | | | | | | | | | | | | | | | |
| N/O | 3045 | 400 | 3660 | 3460 | 74 | 35 | 3 | 25 | 42.5 | 40 | 100 | 50 | 14 | 18.5 | M14 | M6 | 12.5 | 22.8 | 18 | 10 | 11 | 19 | 16 | SQ SSQ RF EG ZG HA DU KZST | Cage: - HW 25 - SHW 25 End pieces: - GFN 3045 - GFO 3045 - GH 3045 - GH-A 3045 - GW 3045 - GW-A 3045 Fastening screw: - GD 3045 - GD 1435 |
| | | 500 | 4575 | 4325 | | | | | | | | | | | | | | | | | | | | | |
| | | 600 | 5490 | 5190 | | | | | | | | | | | | | | | | | | | | | |
| | | 700 | 6405 | 6055 | | | | | | | | | | | | | | | | | | | | | |
| | | 800 | 7320 | 6920 | | | | | | | | | | | | | | | | | | | | | |
| | | 900 | 8235 | 7785 | | | | | | | | | | | | | | | | | | | | | |
| | | 1000 | 9150 | 8650 | | | | | | | | | | | | | | | | | | | | | |
| | | 1100 | 1007 | 9515 | | | | | | | | | | | | | | | | | | | | | |
| | | 1200 | 10980 | 10380 | | | | | | | | | | | | | | | | | | | | | |
| | | 1400 | 12810 | 12110 | | | | | | | | | | | | | | | | | | | | | |
| 1600 | 14640 | 13840 | | | | | | | | | | | | | | | | | | | | | | | |
| N/O | 3555 | 500 | 6156 | 6088 | 78 | 45 | 3.5 | 25 | 45 | 45 | 100 | 50 | 14 | 18.5 | M14 | M6 | 12.5 | 32.5 | 18 | 12 | 11 | 29 | 20 | SQ SSQ RF EG ZG HA DU KZST | Cage: - HW 30 - SHW 30 End pieces: - GFN 3555 - GFO 3555 - GH 3555 - GH-A 3555 - GW 3555 - GW-A 3555 Fastening screw: - GD 3555 - GD 1435 |
| | | 600 | 7387 | 7306 | | | | | | | | | | | | | | | | | | | | | |
| | | 700 | 8618 | 8523 | | | | | | | | | | | | | | | | | | | | | |
| | | 800 | 9850 | 9741 | | | | | | | | | | | | | | | | | | | | | |
| | | 900 | 11081 | 10958 | | | | | | | | | | | | | | | | | | | | | |
| | | 1000 | 12312 | 12176 | | | | | | | | | | | | | | | | | | | | | |
| | | 1100 | 13543 | 13394 | | | | | | | | | | | | | | | | | | | | | |
| | | 1200 | 14774 | 14611 | | | | | | | | | | | | | | | | | | | | | |
| | | 1400 | 17237 | 17046 | | | | | | | | | | | | | | | | | | | | | |
| | | 1600 | 19699 | 19482 | | | | | | | | | | | | | | | | | | | | | |

⁽¹⁾ The lengths listed are standard; other lengths are of course available. The maximum lengths are listed on page 48.

⁽²⁾ B designates the width of a guideway. B2 designates the width over both guideways.

⁽³⁾ Select accessories as follows: Cage type: page 49 and 50, end pieces: pages 51 and 52, fixing screws: page 52

5 Linear guideways

Maximum lengths type N/O

| Type /Size | Quality class (see chapter 9) | Max. lengths in standard material (in mm) | Max lengths in non-corrosive material (in mm) |
|------------|----------------------------------|--|--|
| N/O 62015 | NQ | 1'500 | 900 |
| | SQ | 1'200 | |
| | SSQ | | |
| N/O 92025 | NQ | 3'000 | 3'000 |
| | SQ | | |
| | SSQ | | |
| N/O 2025 | NQ | 3'000 | 3'000 |
| | SQ | | |
| | SSQ | | |
| N/O 2535 | NQ | 3'000 | 3'000 |
| | SQ | | |
| | SSQ | | |
| N/O 3045 | NQ | 3'000 | 3'000 |
| | SQ | | |
| | SSQ | | |
| N/O 3555 | NQ | 3'000 | 3'000 |
| | SQ | | |
| | SSQ | | |

Rail chamfer

The detail of the rail chamfer is shown in the chart below. Please note that the part number and company logo are marked opposite to the datum and supporting surfaces.

| Type / Size | Rail chamfer of reference edges in mm |
|-------------|---------------------------------------|
| N/O 62015 | 0.5 x 45° |
| N/O 92025 | 0.5 x 45° |
| N/O 2025 | 0.5 x 45° |
| N/O 2535 | 0.5 x 45° |
| N/O 3045 | 1.0 x 45° |
| N/O 3555 | 1.0 x 45° |

5 Linear guideways

Accessories for type N/O

Needle cage type SHW

Design:

Needles fixed in plastic provides lower displacement forces and smoother running

Installation method:

For normal application and certain overrunning cage applications

Material:

Stainless steel and plastic PA 12 GF 30 %

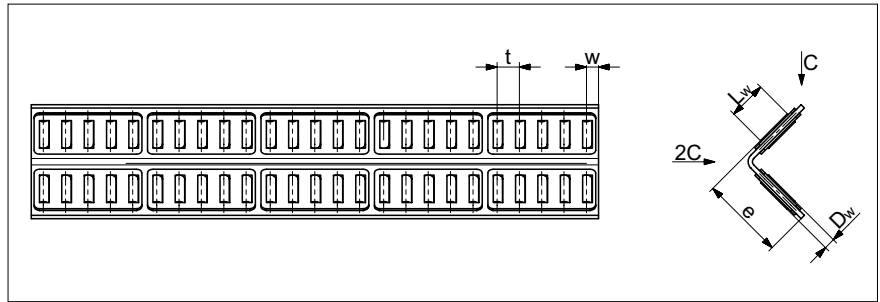

| Type | Size | Dw | Lw | e | t | w | C ₁₀₀ per needle in N | C ₅₀ per needle in N | Compatible with linear guideways type | max. length in mm |
|------|------|-----|------|----|------|-------------|----------------------------------|---------------------------------|---------------------------------------|-------------------|
| SHW | 15 | 2 | 6.8 | 14 | 4 | approx. 2.9 | 750 | 922.50 | N/O 92025 and 2025 | 1'500 |
| | 20 | 2.5 | 9.8 | 19 | 4.75 | approx. 3.4 | 1'375 | 1691.25 | N/O 2535 | 1'500 |
| | 25 | 3 | 13.8 | 25 | 5.2 | approx. 3.6 | 2'350 | 2890.50 | N/O 3045 | 1'500 |
| | 30 | 3.5 | 17.8 | 30 | 6.1 | approx. 4.3 | 3'600 | 4428.00 | N/O 3555 | 1'500 |

Needle cage type SHW with cage control (KZST)

Detailed information on the cage control is listed under Chapter 7.9.

Design:

Needles fixed in plastic. Thus smaller displacement forces and smoother running.

Installation method:

For normal application and certain overrunning cage applications

Material:

Stainless steel and plastic PA 12 GF 30 %

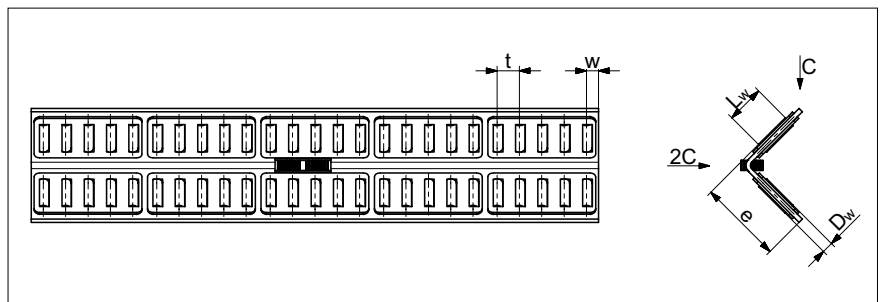

| Type | Size | Dw | Lw | e | t | w | C ₁₀₀ per needle in N | C ₅₀ per needle in N | Compatible with linear guideways type | max. length in mm |
|------|------|-----|------|----|------|-------------|----------------------------------|---------------------------------|---------------------------------------|-------------------|
| SHW | 15 | 2 | 6.8 | 14 | 4 | approx. 2.9 | 750 | 922.50 | N/O 92025 and 2025 | 1'500 |
| | 20 | 2.5 | 9.8 | 19 | 4.75 | approx. 3.4 | 1'375 | 1691.25 | N/O 2535 | 1'500 |
| | 25 | 3 | 13.8 | 25 | 5.2 | approx. 3.6 | 2'350 | 2890.50 | N/O 3045 | 1'500 |
| | 30 | 3.5 | 17.8 | 30 | 6.1 | approx. 4.3 | 3'600 | 4428.00 | N/O 3555 | 1'500 |

5 Linear guideways

Needle cage type HW

Design:
Needles fixed

Installation method:
For normal application and certain overrunning cage applications

Material:
Standard
- Size HW 10 is made out of tool steel
- All other sizes in aluminium
Optional
- All cages are available in steel

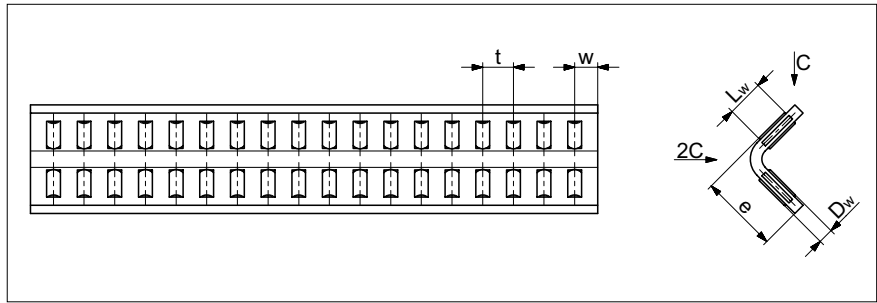

| Type | Size | Dw | L _w | e | t | w | C ₁₀₀ per needle in N | C ₅₀ per needle in N | Compatible with linear guideways type | max. length in mm |
|------|------|-----|----------------|----|-----|-------------|----------------------------------|---------------------------------|---------------------------------------|-------------------|
| HW | 10 | 2 | 4.8 | 10 | 4 | approx. 3 | 530 | 651.90 | N/O 62015 | 1'980 |
| | 15 | 2 | 6.8 | 14 | 4.5 | approx. 3.5 | 750 | 922.50 | N/O 92025 | 1'950 |
| | 16 | 2 | 8.8 | 16 | 3.8 | approx. 2.8 | 970 | 1193.10 | N/O 2025 | 1990 |
| | 20 | 2.5 | 9.8 | 20 | 5.5 | approx. 4 | 1'375 | 1691.25 | N/O 2535 | 1'970 |
| | 25 | 3 | 13.8 | 25 | 6 | approx. 4.5 | 2'350 | 2890.50 | N/O 3045 | 1'940 |
| | 30 | 3.5 | 17.8 | 30 | 7 | approx. 5 | 3'600 | 4428.00 | N/O 3555 | 1'980 |

Needle cage type HW with cage control (KZST)

Detailed information on the cage control is listed under Chapter 7.9.

Design:
Needles fixed

Installation method:
For normal application and certain overrunning cage applications

Material:
Standard
- Size HW 10 is made out of tool steel
- All other sizes in aluminium
Optional
- All cages are available in steel

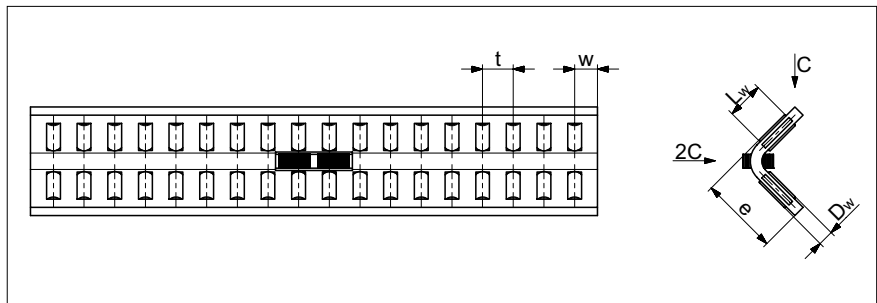

| Type | Size | Dw | L _w | e | t | w | C ₁₀₀ per needle in N | C ₅₀ per needle in N | Compatible with linear guideways type | max. length in mm |
|------|------|-----|----------------|----|-----|-------------|----------------------------------|---------------------------------|---------------------------------------|-------------------|
| HW | 10 | 2 | 4.8 | 10 | 4 | approx. 3 | 530 | 651.90 | N/O 62015 | 1'980 |
| | 15 | 2 | 6.8 | 14 | 4.5 | approx. 3.5 | 750 | 922.50 | N/O 92025 | 1'950 |
| | 16 | 2 | 8.8 | 16 | 3.8 | approx. 2.8 | 970 | 1193.10 | N/O 2025 | 1990 |
| | 20 | 2.5 | 9.8 | 20 | 5.5 | approx. 4 | 1'375 | 1691.25 | N/O 2535 | 1'970 |
| | 25 | 3 | 13.8 | 25 | 6 | approx. 4.5 | 2'350 | 2890.50 | N/O 3045 | 1'940 |
| | 30 | 3.5 | 17.8 | 30 | 7 | approx. 5 | 3'600 | 4428.00 | N/O 3555 | 1'980 |

5 Linear guideways

End piece type GH

Special feature:
For overrunning cage
Installation method:
No restrictions
Scope of supply:
Including end screws

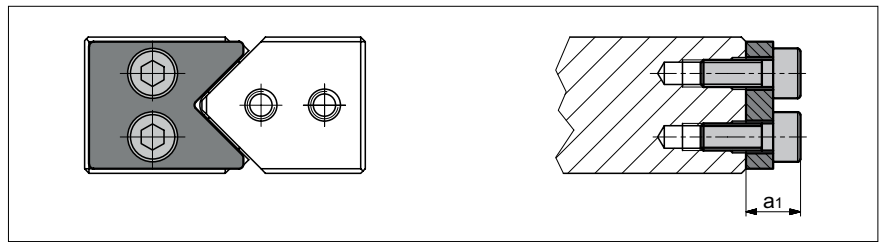

| Size | 62'015 | 92'025 | 2'025 | 2'535 | 3'045 | 3'555 |
|----------------|--------|--------|-------|-------|-------|-------|
| a ₁ | 6 | 7 | 10 | 10 | 10 | 11 |

End piece type GH-A

Special feature:
Wipers made of felt
Installation method:
No restrictions
Scope of supply:
Including end screws

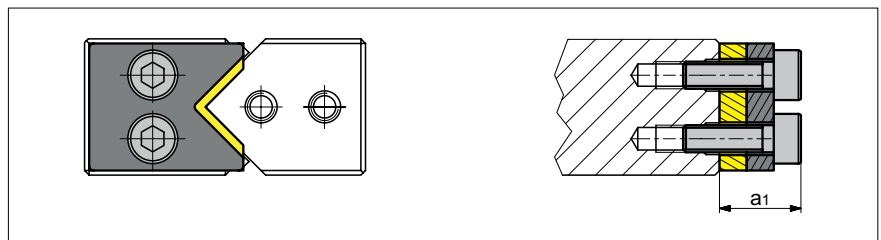

| Size | 62'015 | 92'025 | 2'025 | 2'535 | 3'045 | 3'555 |
|----------------|--------|--------|-------|-------|-------|-------|
| a ₁ | 9 | 10 | 13 | 13 | 13 | 14 |

End piece type GFN/GFO

Installation method:
No restrictions
Scope of supply:
Including end screws

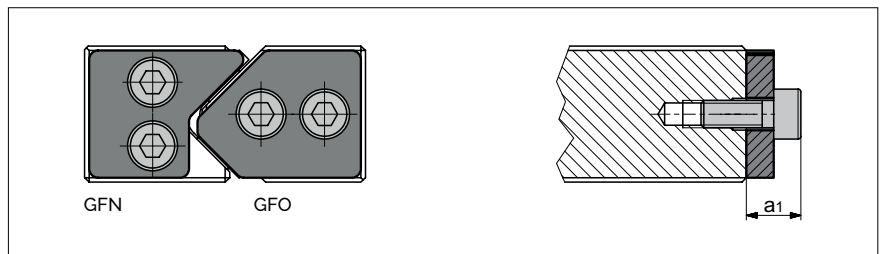

| Size | 62015 | 92025 | 2025 | 2535 | 3045 | 3555 |
|----------------|-------|-------|------|------|------|------|
| a ₁ | 6 | 7 | 10 | 10 | 10 | 11 |

End piece type GW

Special feature:
For overrunning cage
Installation method:
No restrictions
Scope of supply:
Including end screws

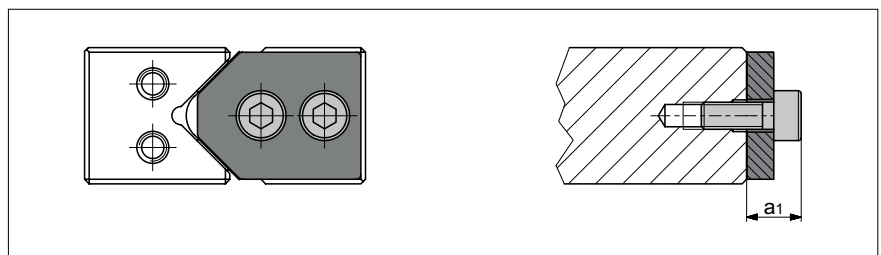

| Size | 62015 | 92025 | 2025 | 2535 | 3045 | 3555 |
|----------------|-------|-------|------|------|------|------|
| a ₁ | 6 | 7 | 10 | 10 | 10 | 11 |

5 Linear guideways

End piece type GW-A

Special feature:

Felt Wipers

Installation method:

No restrictions

Scope of supply:

Including end screws

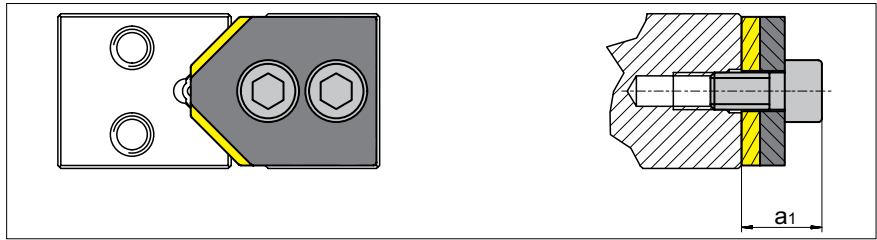

| Size | 62015 | 92025 | 2025 | 2535 | 3045 | 3555 |
|----------------|-------|-------|------|------|------|------|
| a ₁ | 9 | 10 | 13 | 13 | 13 | 14 |

Fastening screws with thin shaft

type GD 6 to GD 1435

Special feature:

To compensate for differences in hole pitches

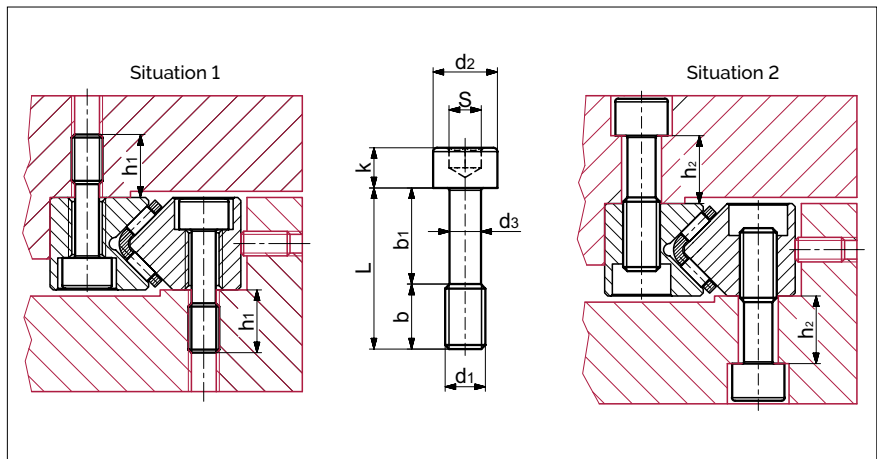

| Type | Size | L | b | b ₁ | d ₁ | d ₂ | d ₃ | k | s | Max. tightening torque in Ncm [Ⓜ] | Compatible with linear guideways type (Situation 1) | Compatible with linear guideways type (Situation 2) |
|------|------|----|----|----------------|----------------|----------------|----------------|----|----|--|---|---|
| GD | 6 | 20 | 8 | 12 | M5 | 8 | 3.9 | 5 | 4 | 463 | N/O 62015 | - |
| | 9 | 30 | 12 | 18 | M6 | 8.5 | 4.6 | 6 | 5 | 762 | N/O 92025 | N/O 62015 |
| | 2025 | 35 | 16 | 19 | M8 | 11.3 | 6.25 | 8 | 6 | 1838 | N/O 2025 | N/O 92025 |
| | 2535 | 40 | 18 | 22 | M10 | 13.9 | 7.9 | 10 | 8 | 3674 | N/O 2535 | N/O 2025 |
| | 3045 | 50 | 25 | 25 | M12 | 15.8 | 9.6 | 12 | 10 | 6579 | N/O 3045 | N/O 2535 |
| | 3555 | 60 | 25 | 35 | M12 | 15.8 | 9.6 | 12 | 12 | 6579 | N/O 3555 | N/O 2535 |
| | 1435 | 90 | 27 | 63 | M14 | 19.5 | 11.2 | 14 | 12 | 10631 | - | N/O 3045 & N/O 3555 |

[Ⓜ] Tightening torques apply for materials with a tensile strength of > 360N/mm²

5 Linear guideways

5.5 Type M/V

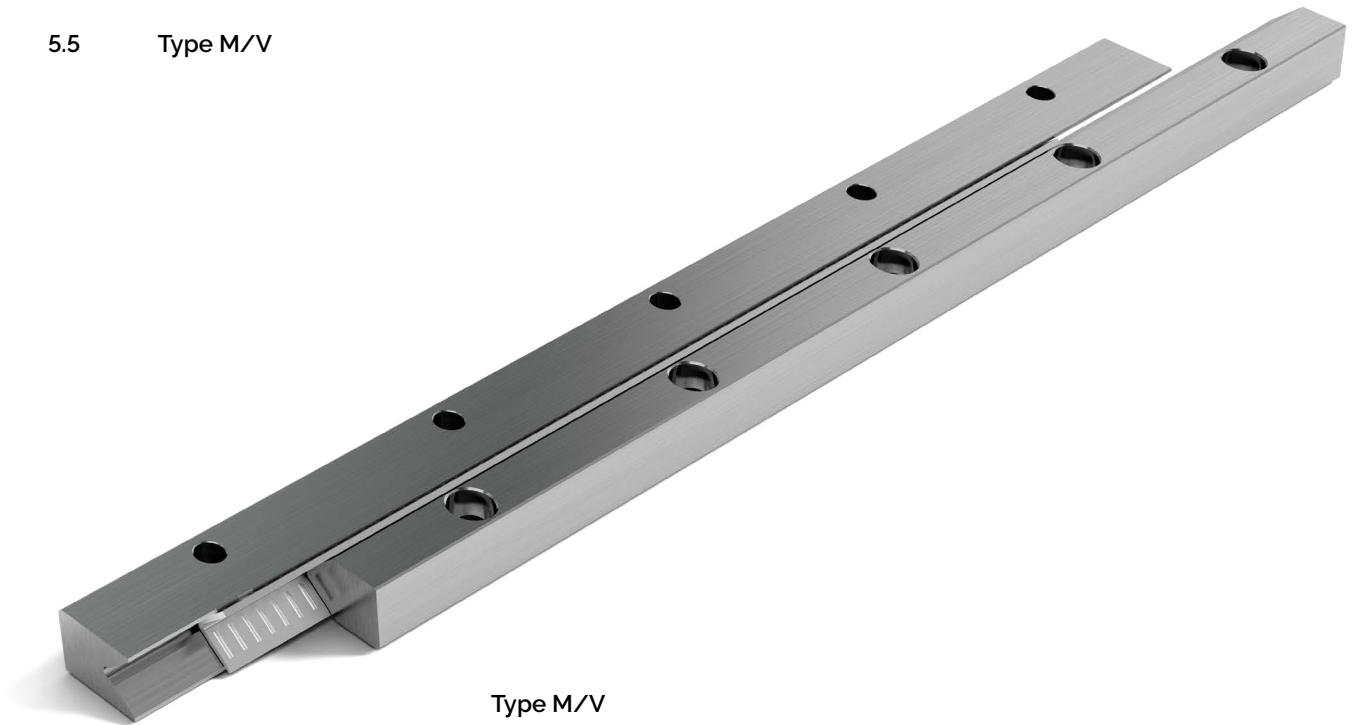

Type M/V

the type M/V linear guideway is similar to type N/O, but differs in its external dimensions. Equipped with needle cages, it is particularly suitable for applications involving a higher load. SCHNEEBERGER M/V bearings have a lower moving resistance due to our composite cage.

Benchmark data

Track and surface quality

- Finely ground supporting and/or locating surfaces and tracks (90° V-profile)

Materials (standard)

- Rails from through hardened tool steel 1.2842, hardness 58 – 62 HRC
- For non-corrosive guideways tool steel 1.4034 and 1.4112 is used
- Rolling element made of through hardened roller bearing steel, hardness 58 – 64 HRC

Rolling element

- Needle

Speed

- 1 m/s

Acceleration

- 50 m/s²
- 200 m/s² with cage control

Accuracy

- Type M/V linear guideways are available in three quality classes (see chapter 9)

Operating temperatures

- -40° C to +80° C

5 Linear guideways

Dimensions and load capacities type M/V

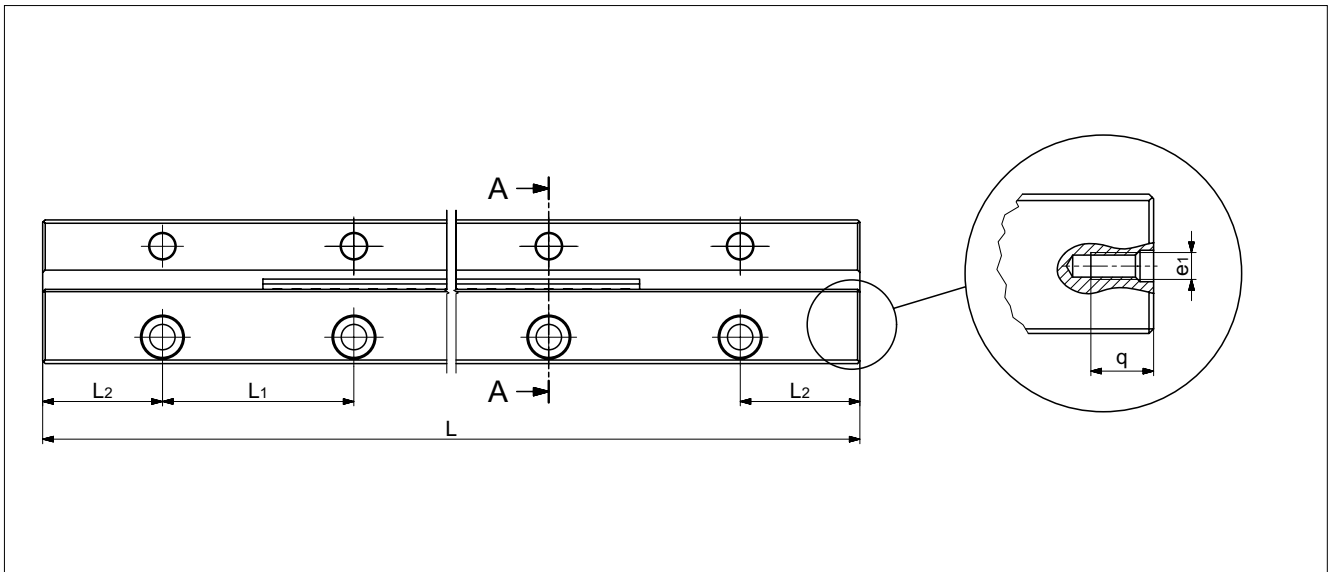

| Type | Size | L in mm ⁽¹⁾ | | Weight in g | A | B/ B ₂ ⁽²⁾ | Dw | F | J | J ₁ | L ₁ | L ₂ | N | a | d | e ₁ | f | g | m | m ₁ | q | u | u ₁ | Options (see chapter 7) | Accessories ⁽³⁾ |
|----------|------|------------------------|--------|-------------|----|-------------------------------------|------|------|-----|-------------------|----------------|----------------|-----|------|----|----------------|------|----|-----|----------------|----|------|---|---|----------------------------|
| | | Type M | Type V | | | | | | | | | | | | | | | | | | | | | | |
| M/V 3015 | 100 | 136 | 154 | 30 | 15 | 2 | 10.5 | 15.5 | 174 | 40 ^(a) | ° | 5.5 | 0.7 | 8.5 | M3 | 5.3 | 10.5 | 8 | 5.5 | 7 | 7 | 7 | SQ SSQ RF EG ZG HA KZST | Cage: - HW 10 End pieces: - EM 3015 - EV 3015 - EAM 3015 - EAV 3015 Fastening screw: - GD 3015 | |
| | 150 | 204 | 231 | | | | | | | | | | | | | | | | | | | | | | |
| | 200 | 272 | 308 | | | | | | | | | | | | | | | | | | | | | | |
| | 300 | 420 | 473 | | | | | | | | | | | | | | | | | | | | | | |
| | 400 | 560 | 631 | | | | | | | | | | | | | | | | | | | | | | |
| | 500 | 700 | 788 | | | | | | | | | | | | | | | | | | | | | | |
| | 600 | 840 | 946 | | | | | | | | | | | | | | | | | | | | | | |
| M/V 4020 | 100 | 261 | 274 | 40 | 20 | 2 | 13.5 | 22.5 | 22 | 80 ^(a) | ° | 7.5 | 1.3 | 11.5 | M5 | 7.5 | 13.2 | 10 | 5.5 | 8 | 11 | 10.5 | SQ SSQ RF EG ZG HA KZST | Cage: - HW 15 - SHW 15 End pieces: - EM 4020 - EV 4020 - EAM 4020 - EAV 4020 Fastening screw: - GD 4020 | |
| | 150 | 392 | 411 | | | | | | | | | | | | | | | | | | | | | | |
| | 200 | 522 | 548 | | | | | | | | | | | | | | | | | | | | | | |
| | 300 | 820 | 815 | | | | | | | | | | | | | | | | | | | | | | |
| | 400 | 1093 | 1087 | | | | | | | | | | | | | | | | | | | | | | |
| | 500 | 1367 | 1358 | | | | | | | | | | | | | | | | | | | | | | |
| | 600 | 1640 | 1630 | | | | | | | | | | | | | | | | | | | | | | |
| M/V 5025 | 100 | 446 | 437 | 50 | 25 | 2 | 17 | 28 | 28 | 80 ^(a) | ° | 10 | 1.3 | 11.5 | M6 | 7.5 | 18.2 | 12 | 7 | 9 | 13 | 13 | SQ SSQ RF EG ZG HA KZST | Cage: - HW 15 - HW 16 - SHW 15 End pieces: - EM 5025 - EV 5025 - EAM 5025 - EAV 5025 Fastening screw: - GD 5025 | |
| | 200 | 893 | 874 | | | | | | | | | | | | | | | | | | | | | | |
| | 300 | 1339 | 1311 | | | | | | | | | | | | | | | | | | | | | | |
| | 400 | 1786 | 1748 | | | | | | | | | | | | | | | | | | | | | | |
| | 500 | 2232 | 2185 | | | | | | | | | | | | | | | | | | | | | | |
| | 600 | 2678 | 2622 | | | | | | | | | | | | | | | | | | | | | | |
| | 700 | 3125 | 3059 | | | | | | | | | | | | | | | | | | | | | | |
| | 800 | 3571 | 3496 | | | | | | | | | | | | | | | | | | | | | | |
| | 900 | 4018 | 3933 | | | | | | | | | | | | | | | | | | | | | | |
| | 1000 | 4464 | 4370 | | | | | | | | | | | | | | | | | | | | | | |

^{a)} for the 100 mm length, the following applies: L₁ = 35 mm (2 x) ° min. 15 mm

^{b)} for the length 100 mm, the following applies: L₁ = 50 mm ° min. 20 mm

⁽¹⁾ The lengths listed are standard; other lengths are of course available. The maximum lengths are listed on page 56.

⁽²⁾ B designates the width of a guideway. B₂ designates the width over both guideways.

⁽³⁾ Select accessories as follows: Cage type: page 57 and 58, end pieces: pages 59, fixing screws: page 60

5 Linear guideways

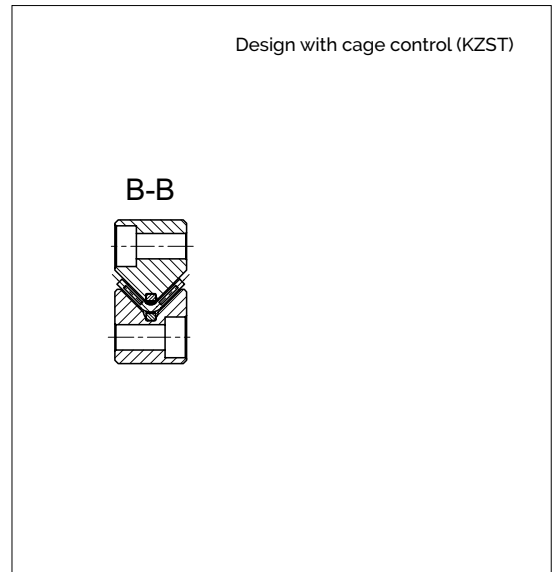
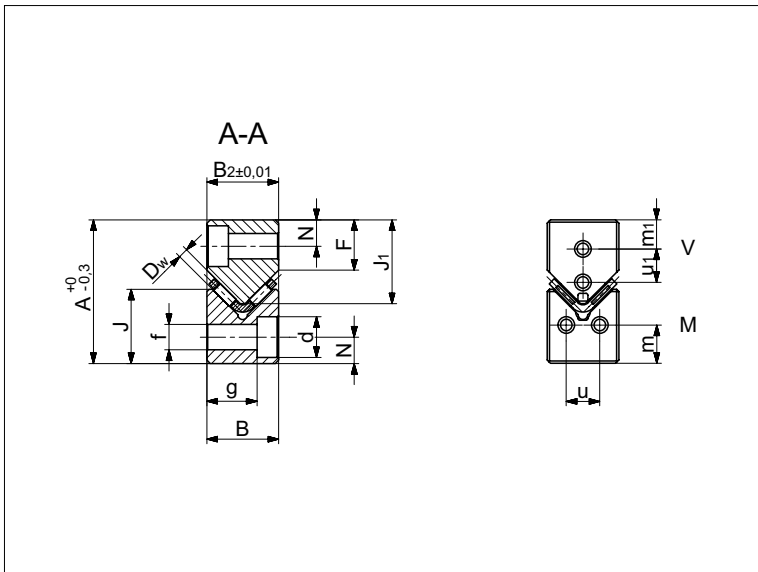

| Type | Size | L in mm ⁽¹⁾ | | Weight in g | A | B/ B ₂ ⁽²⁾ | Dw | F | J | J ₁ | L ₁ | L ₂ | N | a | d | e ₁ | f | g | m | m ₁ | q | u | u ₁ | Options (see chapter 7) | Accessories ⁽³⁾ |
|----------|------|------------------------|--------|-------------|----|-------------------------------------|----|----|------|----------------|----------------|----------------|----|------|----|----------------|----|----|----|----------------|----|----|---|--|----------------------------|
| | | Type M | Type V | | | | | | | | | | | | | | | | | | | | | | |
| M/V 6035 | 200 | 1450 | 1510 | 60 | 35 | 2.5 | 20 | 35 | 35.5 | 100 | 50 | 11 | 13 | 15 | M6 | 10 | 26 | 14 | 8 | 9 | 20 | 18 | SQ SSQ RF EG ZG HA KZST | Cage: - HW 20 - SHW 20 End pieces: - EM 6035 - EV 6035 - EAM 6035 - EAV 6035 Fastening screw: - GD 6035 | |
| | 300 | 2176 | 2265 | | | | | | | | | | | | | | | | | | | | | | |
| | 400 | 2901 | 3020 | | | | | | | | | | | | | | | | | | | | | | |
| | 500 | 3626 | 3775 | | | | | | | | | | | | | | | | | | | | | | |
| | 600 | 4351 | 4530 | | | | | | | | | | | | | | | | | | | | | | |
| | 700 | 5076 | 5285 | | | | | | | | | | | | | | | | | | | | | | |
| | 800 | 5802 | 6040 | | | | | | | | | | | | | | | | | | | | | | |
| | 900 | 6527 | 6795 | | | | | | | | | | | | | | | | | | | | | | |
| 1000 | 7252 | 7550 | | | | | | | | | | | | | | | | | | | | | | | |
| M/V 7040 | 200 | 1934 | 2008 | 70 | 40 | 3 | 24 | 40 | 41.5 | 100 | 50 | 13 | 13 | 18.5 | M6 | 12.5 | 29 | 16 | 10 | 9 | 20 | 20 | SQ SSQ RF EG ZG HA KZST | Cage: - HW 25 - SHW 25 End pieces: - EM 7040 - EV 7040 - EAM 7040 - EAV 7040 Fastening screw: - GD 7040 | |
| | 300 | 2807 | 3019 | | | | | | | | | | | | | | | | | | | | | | |
| | 400 | 3743 | 4025 | | | | | | | | | | | | | | | | | | | | | | |
| | 500 | 4678 | 5032 | | | | | | | | | | | | | | | | | | | | | | |
| | 600 | 5821 | 6038 | | | | | | | | | | | | | | | | | | | | | | |
| | 700 | 6791 | 7044 | | | | | | | | | | | | | | | | | | | | | | |
| | 800 | 7499 | 8051 | | | | | | | | | | | | | | | | | | | | | | |
| | 900 | 8436 | 9057 | | | | | | | | | | | | | | | | | | | | | | |
| 1000 | 9374 | 10321 | | | | | | | | | | | | | | | | | | | | | | | |
| M/V 8050 | 300 | 4014 | 4271 | 80 | 50 | 3.5 | 26 | 45 | 48 | 100 | 50 | 14 | 13 | 20 | M6 | 14 | 37 | 20 | 10 | 9 | 30 | 25 | SQ SSQ RF EG ZG HA KZST | Cage: - HW 30 - SHW 30 End pieces: - EM 8050 - EV 8050 - EAM 8050 - EAV 8050 Fastening screw: - GD 8050 | |
| | 400 | 5352 | 5694 | | | | | | | | | | | | | | | | | | | | | | |
| | 500 | 6690 | 7118 | | | | | | | | | | | | | | | | | | | | | | |
| | 600 | 8290 | 8544 | | | | | | | | | | | | | | | | | | | | | | |
| | 700 | 9672 | 9968 | | | | | | | | | | | | | | | | | | | | | | |
| | 800 | 10700 | 11530 | | | | | | | | | | | | | | | | | | | | | | |
| | 900 | 12038 | 12822 | | | | | | | | | | | | | | | | | | | | | | |
| | 1000 | 13375 | 14247 | | | | | | | | | | | | | | | | | | | | | | |

⁽¹⁾ The lengths listed are standard; other lengths are of course available. The maximum lengths are listed on page 56.

⁽²⁾ B designates the width of a guideway. B₂ designates the width over both guideways.

⁽³⁾ Select accessories as follows: Cage type: page 57 and 58, end pieces: pages 59, fixing screws: page 60

5 Linear guideways

Maximum lengths type M/V

| Type / Size | Quality class | Max. lengths in standard material (in mm) | Max lengths in non-corrosive material (in mm) |
|-------------|---------------|---|---|
| M/V 3015 | NQ | 1500 | 900 |
| | SQ | 1200 | |
| | SSQ | | |
| M/V 4020 | NQ | 3000 | 3000 |
| | SQ | | |
| | SSQ | | |
| M/V 5025 | NQ | 3000 | 3000 |
| | SQ | | |
| | SSQ | | |
| M/V 6035 | NQ | 3000 | 3000 |
| | SQ | | |
| | SSQ | | |
| M/V 7040 | NQ | 3000 | 3000 |
| | SQ | | |
| | SSQ | | |
| M/V 8050 | NQ | 3000 | 3000 |
| | SQ | | |
| | | | |

Rail chamfer

The detail of the rail chamfer is shown in the chart below. Please note that the part number and company logo are marked opposite to the datum and supporting surfaces.

| Type / Size | Rail chamfer of reference edges in mm |
|-------------|---------------------------------------|
| M/V 3015 | 0.5 x 45° |
| M/V 4020 | 1.3 x 45° |
| M/V 5025 | 1.3 x 45° |
| M/V 6035 | 1.3 x 45° |
| M/V 7040 | 1.3 x 45° |
| M/V 8050 | 1.3 x 45° |

5 Linear guideways

Accessories type M/V

Needle cage type SHW

Compatible with:
Linear guideway type M/V

Design:

Needles fixed in plastic provides lower displacement forces and smoother running

Installation method:

For normal application and certain overrunning cage applications

Material:

Stainless steel and plastic PA 12 GF 30 %

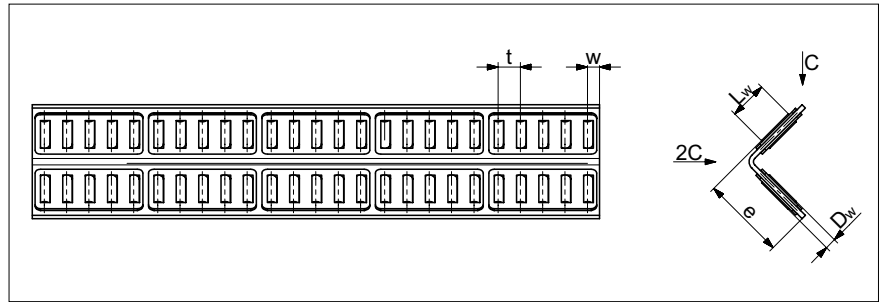

| Type | Size | Dw | Lw | e | t | w | C ₁₀₀ per needle in N | C ₅₀ per needle in N | Compatible with linear guideways type | max. length in mm |
|------|------|-----|------|----|------|-------------|----------------------------------|---------------------------------|---------------------------------------|-------------------|
| SHW | 15 | 2 | 6.8 | 14 | 4 | approx. 2.9 | 750 | 922.50 | M/V 4020 and M/V 5025 | 1'500 |
| | 20 | 2.5 | 9.8 | 19 | 4.75 | approx. 3.4 | 1'375 | 1691.25 | M/V 6035 | 1'500 |
| | 25 | 3 | 13.8 | 25 | 5.2 | approx. 3.6 | 2'350 | 2890.50 | M/V 7040 | 1'500 |
| | 30 | 3.5 | 17.8 | 30 | 6.1 | approx. 4.3 | 3'600 | 4428.00 | M/V 8050 | 1'500 |

Needle cage type SHW with cage control (KZST)

Detailed information on the cage control is listed under Chapter 7.9.

Compatible with:
Linear guideway type M/V

Design:

Needles fixed in plastic. Thus smaller displacement forces and smoother running.

Installation method:

For normal application and certain overrunning cage applications

Material:

Stainless steel and plastic PA 12 GF 30 %

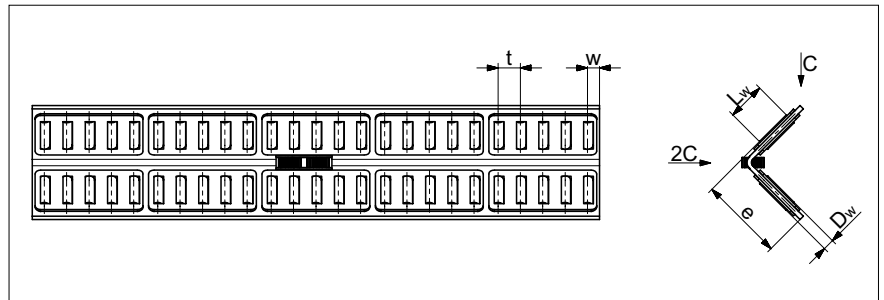

| Type | Size | Dw | Lw | e | t | w | C ₁₀₀ per needle in N | C ₅₀ pro Nadel in N | Compatible with linear guideways type | max. length in mm |
|------|------|-----|------|----|------|-------------|----------------------------------|--------------------------------|---------------------------------------|-------------------|
| SHW | 15 | 2 | 6.8 | 14 | 4 | approx. 2.9 | 750 | 922.50 | M/V 4020 and M/V 5025 | 1'500 |
| | 20 | 2.5 | 9.8 | 19 | 4.75 | approx. 3.4 | 1'375 | 1691.25 | M/V 6035 | 1'500 |
| | 25 | 3 | 13.8 | 25 | 5.2 | approx. 3.6 | 2'350 | 2890.50 | M/V 7040 | 1'500 |
| | 30 | 3.5 | 17.8 | 30 | 6.1 | approx. 4.3 | 3'600 | 4428.00 | M/V 8050 | 1'500 |

5 Linear guideways

Needle cage type HW

Compatible with:
Linear guideway type M/V

Design:
Needles fixed

Installation method:
Specifically suitable as an overrunning cage

Material:
Standard
- Size HW 10 is made out of tool steel
- All other sizes in aluminium
Optional
- All cages are available in steel

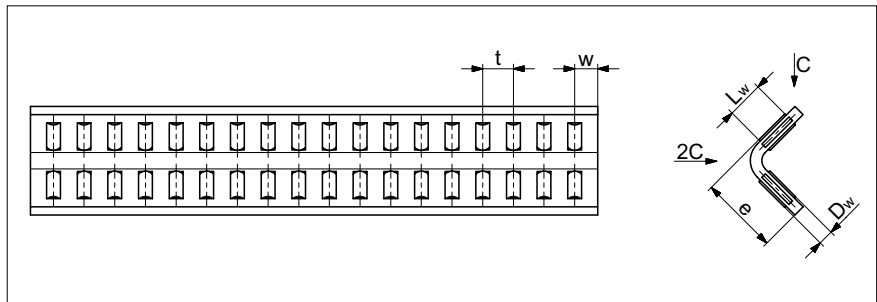

| Type | Size | Dw | L _w | e | t | w | C ₁₀₀ per needle in N | C ₅₀ per needle in N | Compatible with linear guideways type | max. length in mm |
|------|------|-----|----------------|----|-----|-------------|----------------------------------|---------------------------------|---------------------------------------|-------------------|
| HW | 10 | 2 | 4.8 | 10 | 4 | approx. 3 | 530 | 651.90 | M/V 3015 | 1980 |
| | 15 | 2 | 6.8 | 14 | 4.5 | approx. 3.5 | 750 | 922.50 | M/V 4020 and M/V 5025 | 1950 |
| | 16 | 2 | 8.8 | 16 | 3.8 | approx. 2.8 | 970 | 1193.10 | M/V 5025 | 1990 |
| | 20 | 2.5 | 9.8 | 20 | 5.5 | approx. 4 | 1'375 | 1691.25 | M/V 6035 | 1970 |
| | 25 | 3 | 13.8 | 25 | 6 | approx. 4.5 | 2'350 | 2890.50 | M/V 7040 | 1940 |
| | 30 | 3.5 | 17.8 | 30 | 7 | approx. 5 | 3'600 | 4428.00 | M/V 8050 | 1980 |

Needle cage type HW with cage control (KZST)

Detailed information on the cage control is listed under Chapter 7.9.

Compatible with:
Linear guideway type M/V

Design:
Needles fixed

Installation method:
Specifically suitable as an overrunning cage

Material:
Standard
- Size HW 10 is made out of tool steel
- All other sizes in aluminium
Optional
- All cages are available in steel

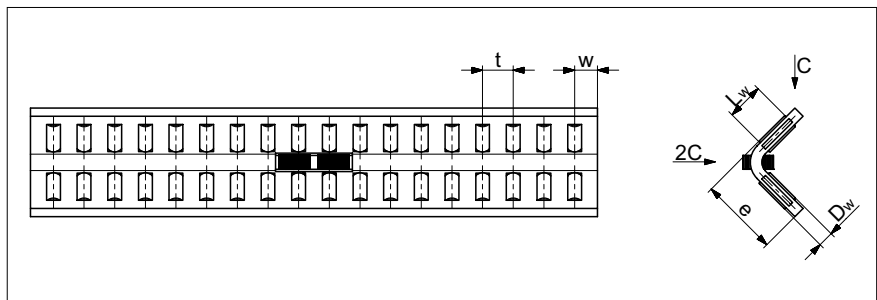

| Type | Size | Dw | L _w | e | t | w | C ₁₀₀ per needle in N | C ₅₀ per needle in N | Compatible with linear guideways type | max. length in mm |
|------|------|-----|----------------|----|-----|-------------|----------------------------------|---------------------------------|---------------------------------------|-------------------|
| HW | 10 | 2 | 4.8 | 10 | 4 | approx. 3 | 530 | 651.90 | M/V 3015 | 1980 |
| | 15 | 2 | 6.8 | 14 | 4.5 | approx. 3.5 | 750 | 922.50 | M/V 4020 and M/V 5025 | 1950 |
| | 16 | 2 | 8.8 | 16 | 3.8 | approx. 2.8 | 970 | 1193.10 | M/V 5025 | 1990 |
| | 20 | 2.5 | 9.8 | 20 | 5.5 | approx. 4 | 1'375 | 1691.25 | M/V 6035 | 1970 |
| | 25 | 3 | 13.8 | 25 | 6 | approx. 4.5 | 2'350 | 2890.50 | M/V 7040 | 1940 |
| | 30 | 3.5 | 17.8 | 30 | 7 | approx. 5 | 3'600 | 4428.00 | M/V 8050 | 1980 |

5 Linear guideways

End piece type EM/EV

Compatible with:
For all M/V rail sizes

Installation method:
No restrictions

Scope of supply:
Including fastening screws

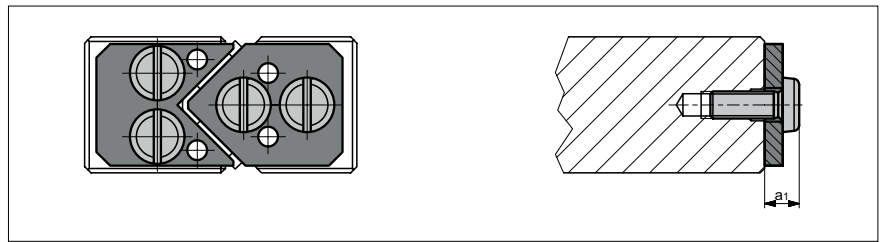

| Size | 3'015 | 4'020 | 5'025 | 6'035 | 7'040 | 8'050 |
|----------------|-------|-------|-------|-------|-------|-------|
| a ₁ | 5 | 8 | 9 | 9 | 9 | 9 |

End piece type EAM

Special feature:
With wipers made of plastic

Compatible with:
For all M/V rail sizes

Installation method:
No restrictions

Scope of supply:
Including fastening screws

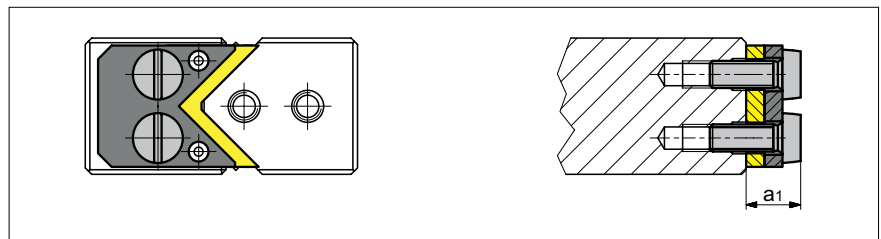

| Size | 3015 | 4020 | 5025 | 6035 | 7040 | 8050 |
|----------------|------|------|------|------|------|------|
| a ₁ | 7 | 10 | 11 | 11 | 11 | 11 |

End piece type EAV

Special feature:
With wipers made of plastic

Compatible with:
For all M/V rail sizes

Installation method:
No restrictions

Scope of supply:
Including fastening screws

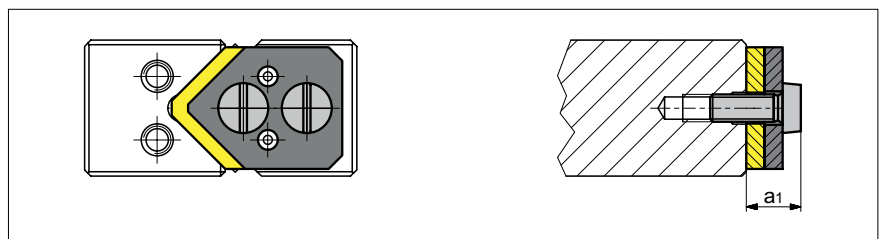

| Size | 3015 | 4020 | 5025 | 6035 | 7040 | 8050 |
|----------------|------|------|------|------|------|------|
| a ₁ | 7 | 10 | 11 | 11 | 11 | 11 |

5 Linear guideways

Fastening screws with thin shaft type GD 3015 to GD 8050

Special feature:

To compensate for differences in hole pitches

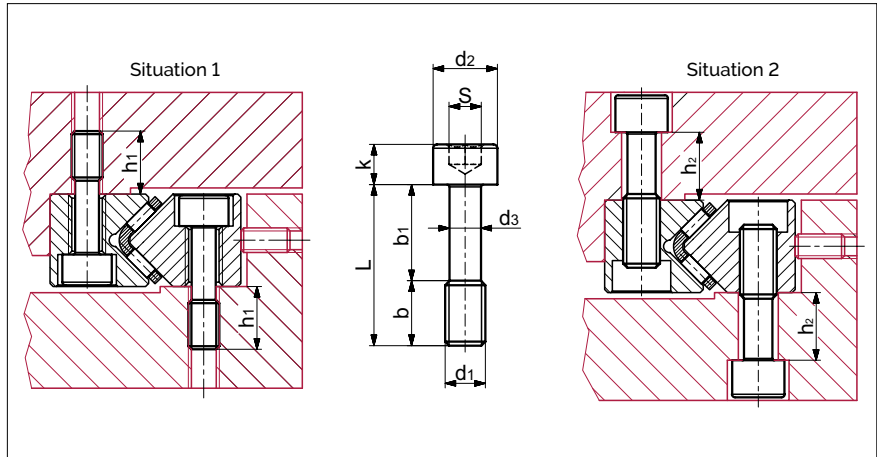

| Type | Size | L | b | b ₁ | d ₁ | d ₂ | d ₃ | k | s | Max. tightening torque in Ncm* | Compatible with guideways of size (Situation 1) | Compatible with guideways of size (Situation 1)** |
|------|------|----|----|----------------|----------------|----------------|----------------|----|----|--------------------------------|---|---|
| GD | 3015 | 25 | 13 | 12 | M4 | 7 | 3 | 4 | 3 | 221 | M/V3015 | M/V3015 |
| | 4020 | 30 | 12 | 18 | M6 | 8.5 | 4.6 | 6 | 5 | 762 | M/V4020 | M/V4020 |
| | 5025 | 35 | 13 | 22 | M6 | 8.5 | 4.6 | 6 | 5 | 762 | M/V5025 | M/V5025 |
| | 6035 | 45 | 17 | 28 | M8 | 11.3 | 6.25 | 8 | 6 | 1838 | M/V6035 | M/V6035 |
| | 7040 | 50 | 19 | 31 | M10 | 13.9 | 7.9 | 10 | 8 | 3674 | M/V7040 | M/V7040 |
| | 8050 | 60 | 21 | 39 | M12 | 15.8 | 9.6 | 12 | 10 | 6579 | M/V8050 | M/V8050 |

* Tightening torques apply for materials with a tensile strength of > 360N/mm²

** Situation 2 applies only for hole variant G (see chapter 7.10)

6 Recirculating unit

Product specifications

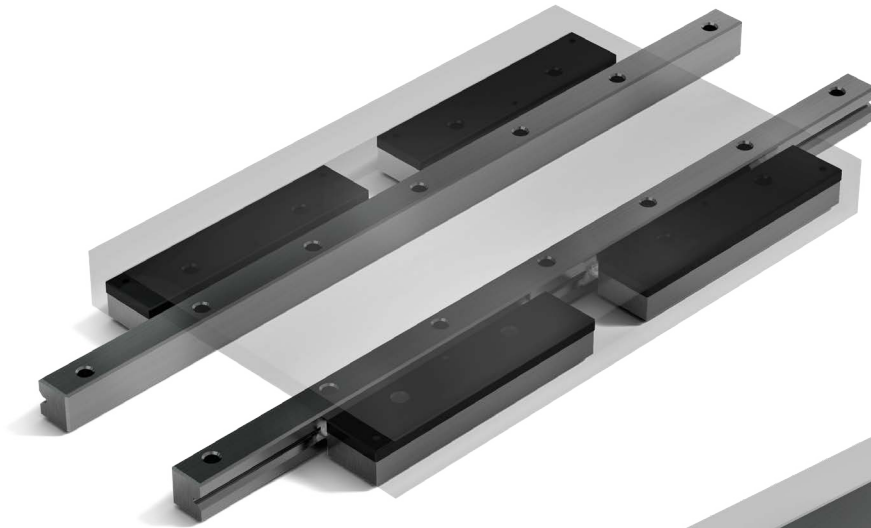

Application with recirculating units and linear guideways of type R



Application with recirculating units and a linear guideway of type RD

Recirculating units support high-precision, rigid and compact structures with unlimited travel. They are used as standard with linear guideways of type R or RD.

The SCHNEEBERGER product range includes recirculating units in different versions and for different load capacities; with rollers or balls, with damping elements or for minimal lubrication .

The range is modular in structure and depending on the type includes sizes from 1 to 12.

6 Recirculating unit

6.1 Type SK and SKD



Type SK



Type SKD

The type SK recirculating unit is equipped with balls and is suitable for small to medium loads.

This recirculating unit is used combined with SCHNEEBERGER linear guideways of type R and/or RD. The SK units can be used in space saving designs that have equal loading in all directions.

Sizes 6 and 9 (size 12 on request) can additionally be equipped with damping elements (type designation SKD). These provide improved smoothness with slightly reduced load carrying capacity.

Benchmark data

Supporting structure

- Hardened and ground with high precision

Materials

- Supporting structure made of through hardened tool steel, hardness 58 - 62 HRC
- Rolling element made of through hardened roller bearing steel, hardness 58 - 64 HRC
- Transmission part in sizes 1, 2, 9 and 12 made of anodized aluminium
- Transmission part in sizes 3 and 6t depending on the length made of plastic or aluminium
- Non-corrosive version on request
- Damping elements for SKD made of plastic
- Wipers made of plastic

Wipers

- From size 3 interchangeable track wipers are made from plastic as standard fitted

Speed

- 2 m/s

Acceleration

- 50 m/s²

Operating temperatures

- -40° C to +80° C

Same installation with the following recirculating units

- • SKC and SR

Can be combined with the following products

- Linear guideway type R and RD

6 Recirculating unit

Dimensions and load capacities type SK and SKD

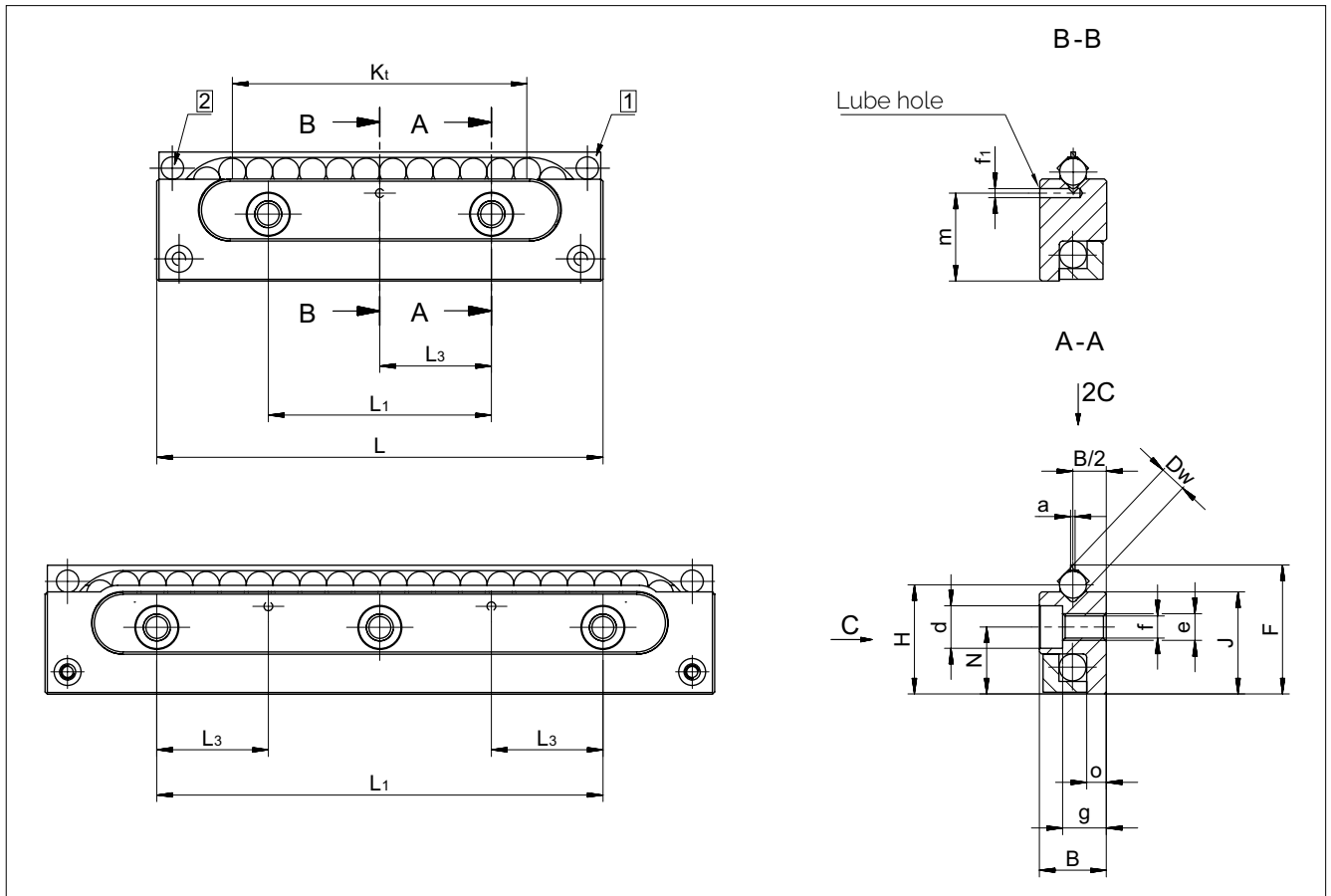

- 1 Retaining web may not be used as a stop
- 2 Wiper from size SK 3-075

| Type and size | Weight in g | B | Dw | F | H | J | K _t | L | L ₁ | L ₃ | N | a | d | e | f | f ₁ | g | m | o | C in N | | Options (see chapter 8) | |
|---------------|--------------|------|-----|----|------|------|----------------|-----|----------------|----------------|------|-----|-----|------|-----|----------------|-----|------|------|--------|-------|----------------------------|----|
| | | SK | SKD | SK | SKD | SK | SKD | SK | SKD | SK | SKD | SK | SKD | SK | SKD | SK | SKD | SK | SKD | SK | SKD | | |
| SK 1-022 | | 5 | 4 | 15 | 8.4 | 7.25 | 6.9 | 9 | 22 | 10 | - | 4.8 | 0.3 | 3 | M2 | 165 | - | 2.6 | - | 12 | 63 | | GP |
| SK 2-032 | | 10 | 6 | 2 | 11 | 9.5 | 9 | 16 | 32 | 15 | - | 6 | 0.3 | 4.4 | M3 | 255 | - | 4 | - | 19 | 135 | | GP |
| SK 3-075 | | 45 | 8 | 3 | 16.9 | 14.5 | 13.8 | 48 | 75 | 25 | 12.5 | 9 | 0.5 | 6 | M4 | 3.3 | 15 | 4.9 | 11.5 | 2.4 | 425 | | GP |
| SK 6-100 | SKD 6-100 | 200 | 15 | 6 | 28.9 | 24.5 | 22.9 | 60 | 100 | 50 | 25 | 15 | 1 | 9.5 | M6 | 5.2 | 2 | 9.8 | 19.7 | 4.4 | 715 | 650 | GP |
| SK 6-150 | SKD 6-150 | 300 | | | | | | 102 | 150 | 2 x 50 | | | | | | | | | | | 1170 | 1100 | |
| SK 9-150 | SKD 9-150 | 670 | 22 | 9 | 45.1 | 39 | 36.7 | 90 | 150 | 100 | 50 | 26 | 15 | 10.5 | M8 | 6.8 | 3 | 15.8 | 32.4 | 6.3 | 1'650 | 1'500 | GP |
| SK 9-200 | SKD 9-200 | 940 | | | | | | 144 | 200 | | | | | | | | | | | | 2'550 | 2'400 | |
| SK 12-2001) | SKD 12-2001) | 1470 | 28 | 12 | 57.1 | 49 | 45.9 | 120 | 200 | 100 | 50 | 32 | 2 | 13.5 | M10 | 8.5 | 3 | 19.8 | 40.2 | 7.7 | 2'860 | 2'600 | GP |

¹⁾ SK 12 and SKD 12 are only available upon request

6 Recirculating unit

Installed dimensions and permissible torque for type SK and SKD

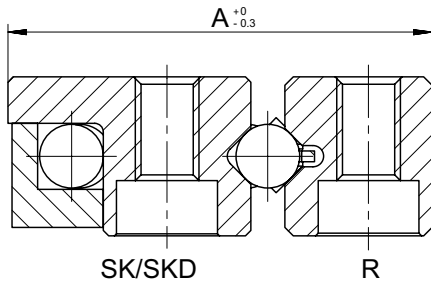

Installed dimensions for type SK and SKD

| Type | Size | A | A ₁ | e ₁ |
|--------------------------|--------|-----|----------------|----------------|
| SK | 1-022 | 115 | 28 | M16 |
| | 2-032 | 155 | 37 | M2.5 |
| | 3-075 | 235 | 57 | M3 |
| SK and SKD | 6-100 | 40 | 94 | M5 |
| | 6-150 | 40 | 94 | M5 |
| | 9-150 | 61 | 150 | M6 |
| | 9-200 | 61 | 150 | M6 |
| SK and SKD ¹⁾ | 12-200 | 78 | 175 | M8 |

¹⁾ SK 12 und SKD 12 sind nur auf Anfrage erhältlich

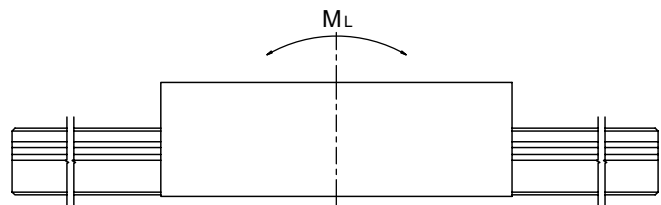
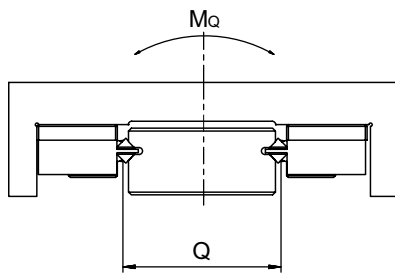
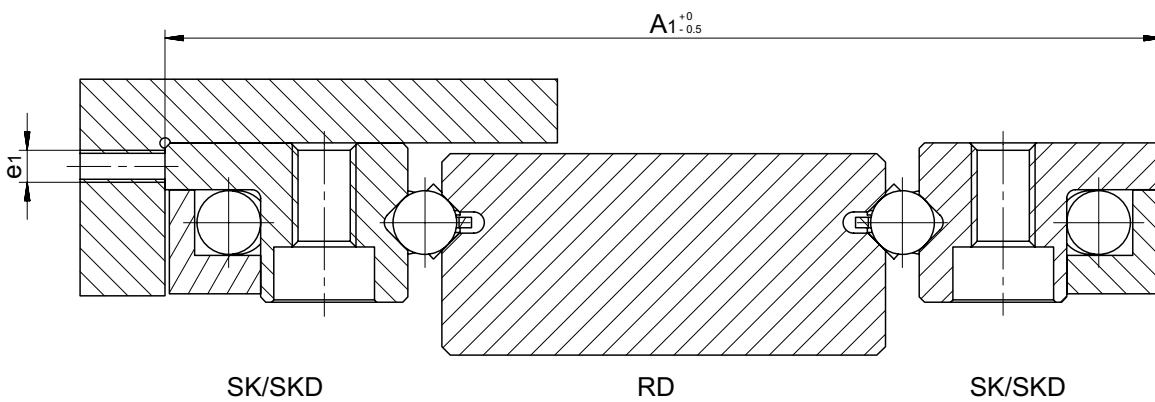

Permissible torques for type SK and SKD

| Type | Size | Q | M _L in Nm | | M ₀ in Nm | |
|--------------------------|--------|------|----------------------|-------|----------------------|-------|
| | | | SK | SKD | SK | SKD |
| SK | 1-023 | 13.5 | 0.4 | | 0.8 | |
| | 2-033 | 18.0 | 14 | | 24 | |
| | 3-076 | 28.0 | 72 | | 120 | |
| SK and SKD | 6-100 | 45.0 | 23.0 | 23.0 | 32.0 | 29.0 |
| | 6-150 | | 40.0 | 40.0 | 53.0 | 50.0 |
| | 9-150 | 72.0 | 81.0 | 81.0 | 119.0 | 108.0 |
| | 9-200 | | 130.0 | 130.0 | 184.0 | 173.0 |
| SK and SKD ¹⁾ | 12-200 | 77.0 | 187.0 | 187.0 | 220.0 | 200.0 |

¹⁾SK 12 and SKD 12 are only available upon request

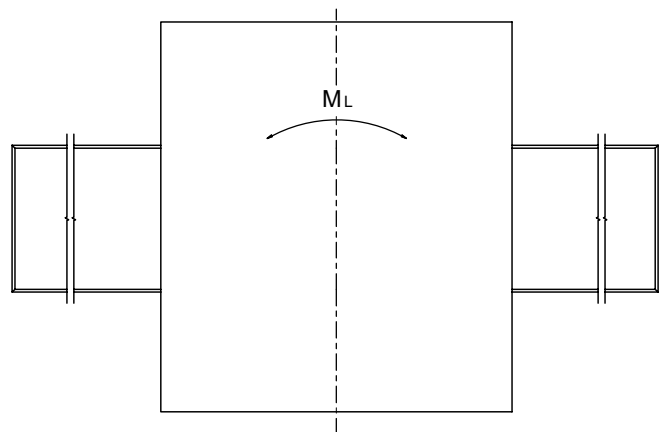

6 Recirculating unit

6.2 Type SKC



The recirculating unit type SKC was developed for minimal lubrication, vacuum and clean room applications. It is made out of DURALLOY® coated steel and has ceramic balls, which are separated from one another by balls made out of TEFLON®.

This recirculating unit is used combined with SCHNEEBERGER linear guideways of type R and/or RD. The SKC units can be used in space saving designs that have equal loading in all directions. It is suitable for small to medium loads.

Benchmark data

Supporting structure

- Hardened and ground and coated with high precision

Materials

- Supporting structure made of stainless steel 1.4034, DURALLOY® coated, hardness min. 54 HRC
- Transmission part made out of stainless steel 1.4034
- Rolling element made of ceramic (balls made of TEFLON® between the ceramic balls are responsible for minimal friction)

Speed

- 2 m/s

Acceleration

- 50 m/s²

Operating temperatures

- -150° C to +200° C

Same installation with the following recirculating units

- SK, SKD and SR

Can be combined with the following products

- Linear guideway type R and RD

6 Recirculating unit

Dimensions and load capacities of type SKC

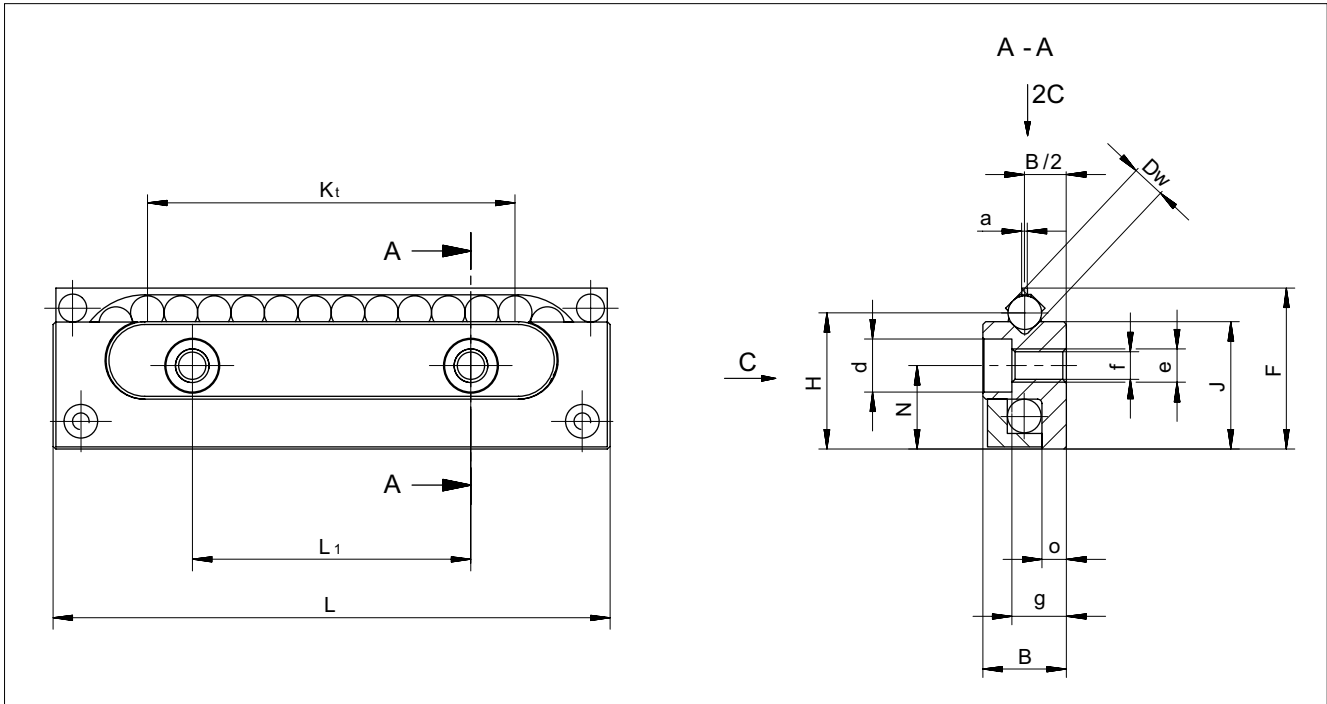

| Type and size | Weight in g | B | Dw | F | H | J | K_t | L | L_1 | N | a | d | e | f | g | o | C* in N | Options (see chapter 8) |
|---------------|-------------|----|----|------|------|------|-------|-----|-------|----|-----|-----|----|-----|-----|-----|---------|----------------------------|
| SKC 3-075 | 44 | 8 | 3 | 16.9 | 14.5 | 13.8 | 48 | 75 | 25 | 9 | 0.5 | 6 | M4 | 3.3 | 4.9 | 2.4 | 75 | GP |
| SKC 6-100 | 212 | 15 | 6 | 28.9 | 24.5 | 22.9 | 60 | 100 | 50 | 15 | 1 | 9.5 | M6 | 5.2 | 9.8 | 4.4 | 125 | GP |

* Loading capacity for minimal lubrication

6 Recirculating unit

Installed dimensions and permissible torques for type SKC

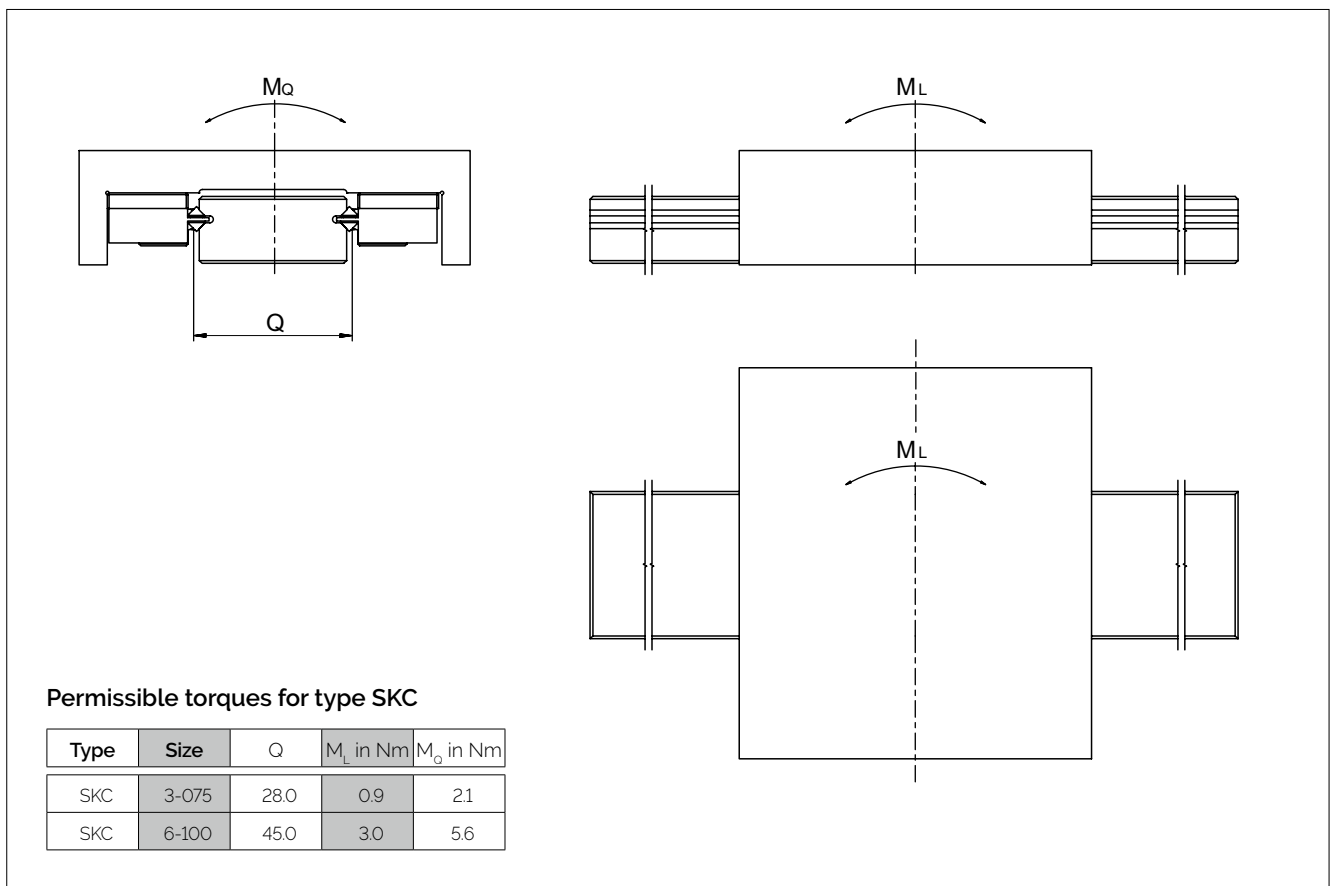
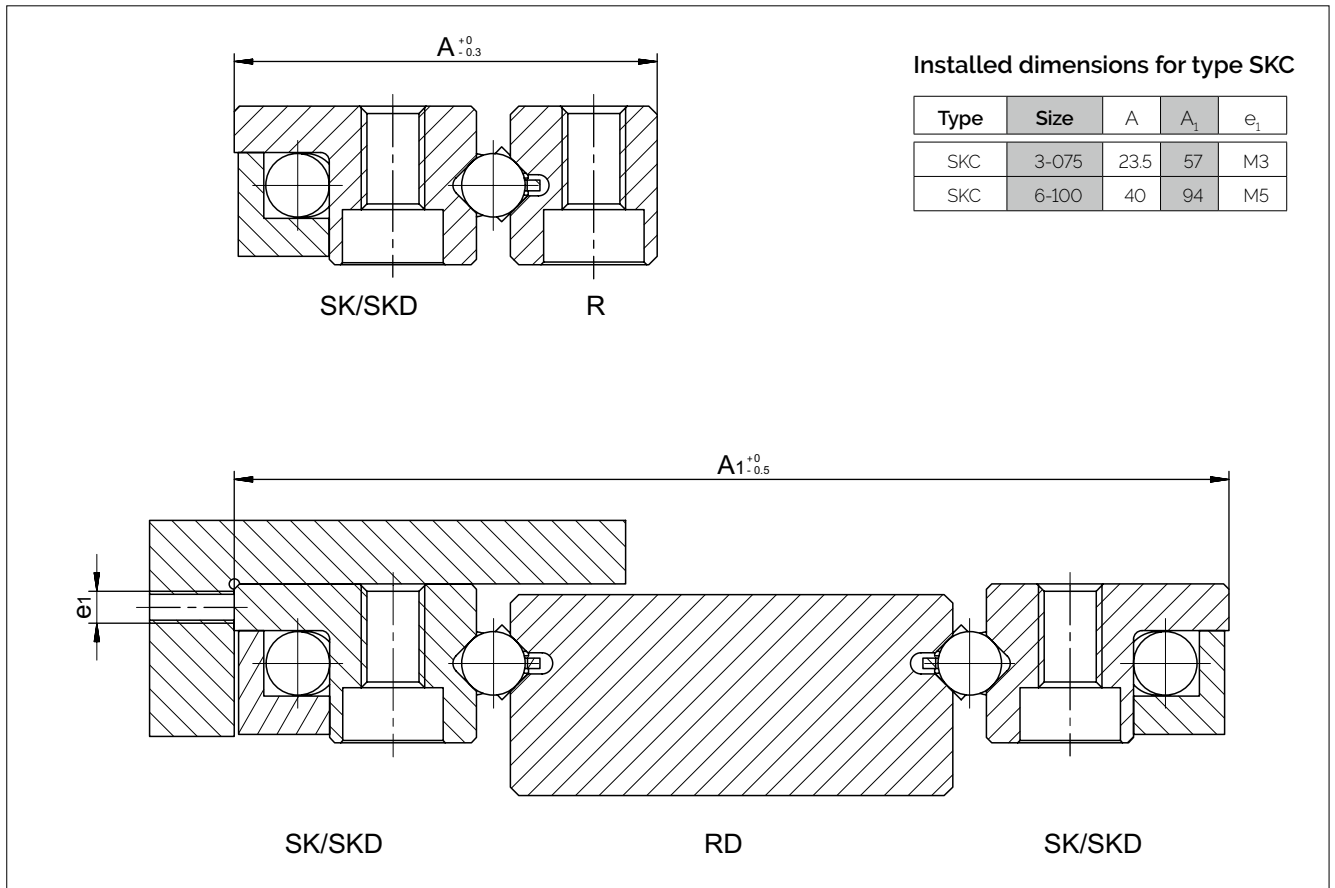

6 Recirculating unit

6.3 Type SR



The SR recirculating units has cross rollers and is suitable for medium to high loads.

This recirculating unit is used combined with SCHNEEBERGER linear guideways of type R and/or RD. In this way space-saving designs can be created that can be equally loaded in all directions.

Benchmark data

Supporting structure

- Hardened and ground with high precision

Materials

- Supporting structure made of through hardened tool steel, hardness 58 – 62 HRC
- Rolling element made of through hardened roller bearing steel, hardness 58 – 64 HRC
- Transmission part depending on the length made of plastic or anodized aluminium
- Stainless steel on request
- From size 3 the rollers are laid in plastic shoes

Speed

- 2 m/s

Acceleration

- 50 m/s²

Operating temperatures

- -40° C to +80° C

Same installation with the following recirculating units

- SK, SKD and SKC

Can be combined with the following products

- Linear guideway type R and RD

6 Recirculating unit

Dimensions and load capacities of type SR

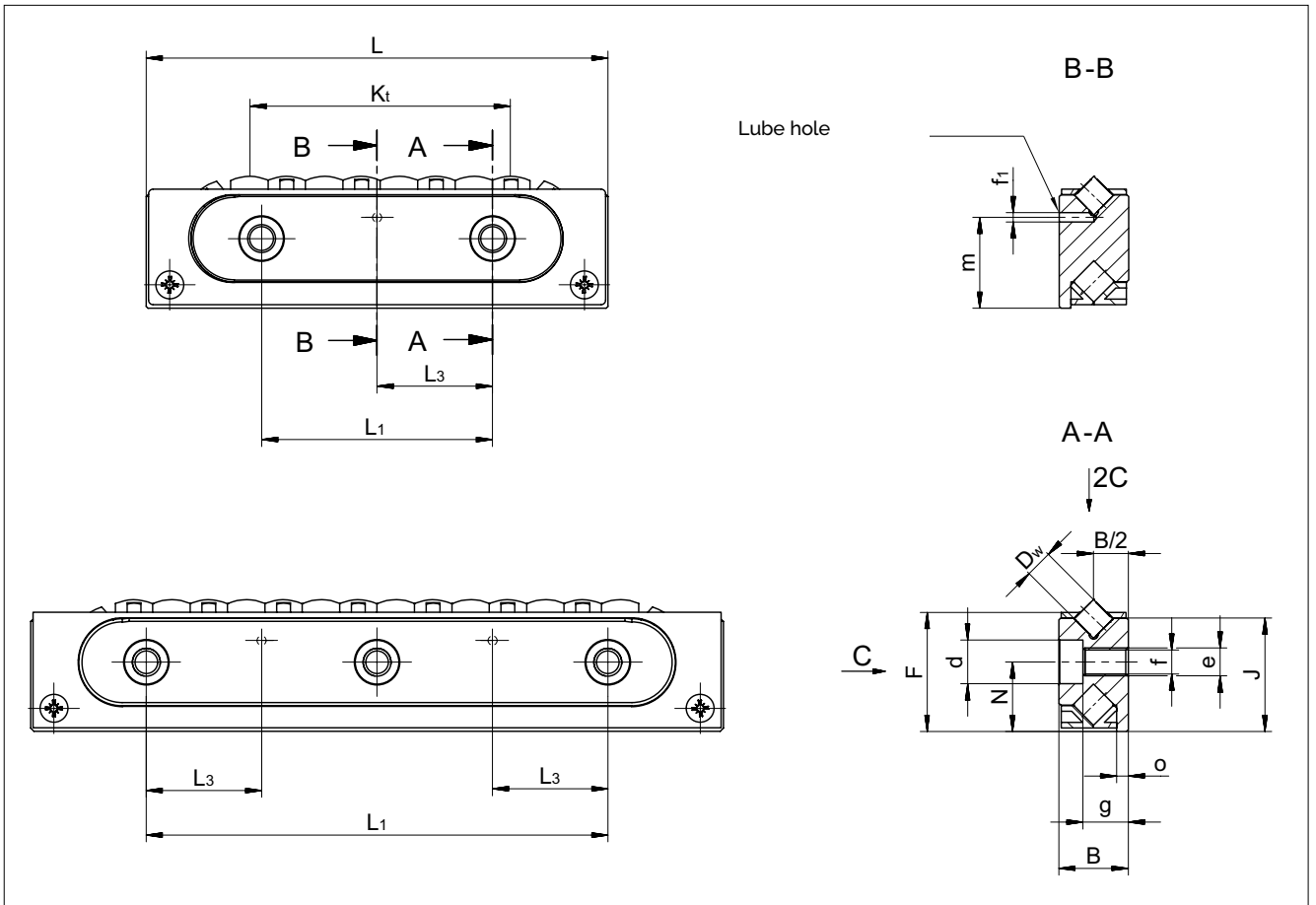

| Type and size | Weight in g | B | Dw | F | J | K _t | L | L ₁ | L ₃ | N | d | e | f | f ₁ | g | m | o | C in N | Options (see chapter 8) |
|-------------------------|-------------|----|----|------|------|----------------|-----|----------------|----------------|----|------|-----|------|----------------|------|------|-----|--------|-------------------------|
| SR 2-032 | 10 | 6 | 2 | 9.8 | 9.5 | 16 | 32 | 15 | - | 6 | 4.4 | M3 | 2.55 | - | 4 | - | 1 | 380 | GP |
| SR 3-075 | 50 | 8 | 3 | 15 | 14.5 | 46 | 75 | 25 | 12.5 | 9 | 6 | M4 | 3.3 | 1.5 | 4.9 | 11.8 | 13 | 850 | GP |
| SR 6-100 | 210 | 15 | 6 | 25.7 | 24.5 | 56 | 100 | 50 | 25 | 15 | 9.5 | M6 | 5.2 | 2 | 9.8 | 19.7 | 2.5 | 2'150 | GP |
| SR 6-150 | 310 | | | | | 105 | 150 | 50 | | | | | | | | | | 3'750 | |
| SR 9-150 | 750 | 22 | 9 | 40.5 | 39 | 92 | 150 | 100 | 50 | 26 | 10.5 | M8 | 6.8 | 3 | 15.8 | 32.4 | 3.5 | 5'850 | GP |
| SR 12-200 ¹⁾ | 1'580 | 28 | 12 | 51.5 | 49 | 112 | 200 | 100 | 50 | 32 | 13.5 | M10 | 8.5 | 3 | 19.8 | 40.2 | 4 | 10'000 | GP |

¹⁾ SR 12 sind nur auf Anfrage erhältlich

6 Recirculating unit

Installed dimensions and permissible torques for type SR

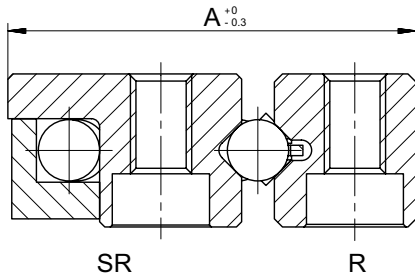

Installed dimensions for type SR

| Type and size | A | A ₁ | e ₁ |
|-------------------------|------|----------------|----------------|
| SR 2-032 | 15.5 | 37 | M2.5 |
| SR 3-075 | 23.5 | 57 | M3 |
| SR 6-100 | 40 | 94 | M5 |
| SR 6-150 | 40 | 94 | M5 |
| SR 9-150 | 61 | 150 | M6 |
| SR 12-200 ¹⁾ | 78 | 175 | M8 |

¹⁾ SR 12 sind nur auf Anfrage erhältlich

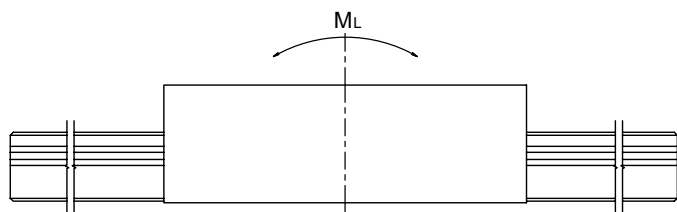
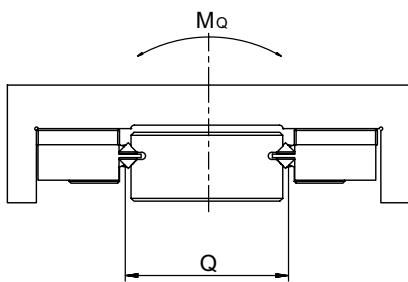
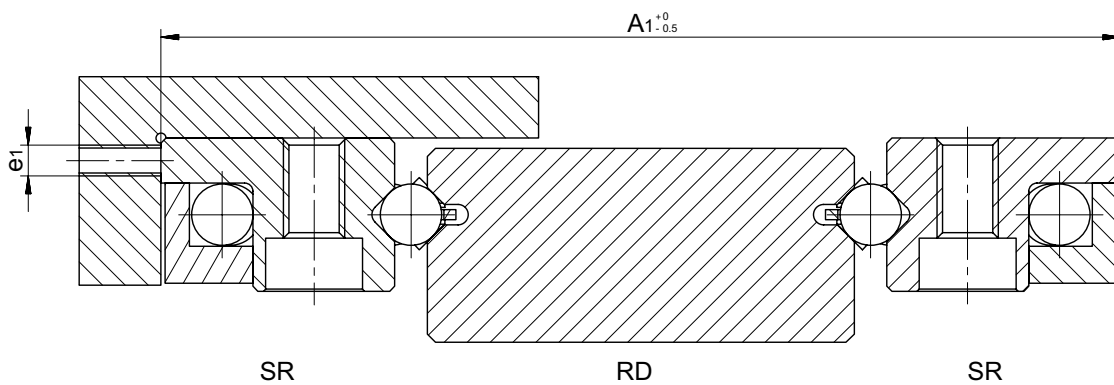

Torques for type SR

| Type and size | Q | M _L in Nm | M _Q in Nm |
|-------------------------|------|----------------------|----------------------|
| SR 2-032 | 18.0 | 3.0 | 7.0 |
| SR 3-075 | 28.0 | 12.0 | 24.0 |
| SR 6-100 | 45.0 | 60.0 | 97.0 |
| SR 6-150 | | 112.0 | 169.0 |
| SR 9-150 | 72.0 | 241.0 | 421.0 |
| SR 12-200 ¹⁾ | 77.0 | 553.0 | 770.0 |

¹⁾ SR 12 sind nur auf Anfrage erhältlich

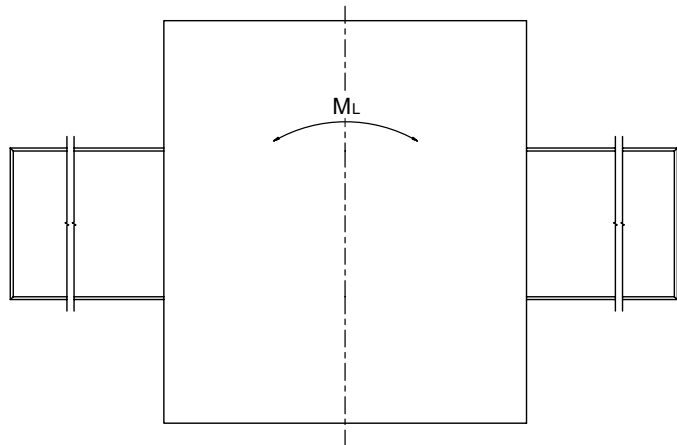

6 Recirculating unit

6.4 Type NRT (with NRV)



Recirculating unit type NRT

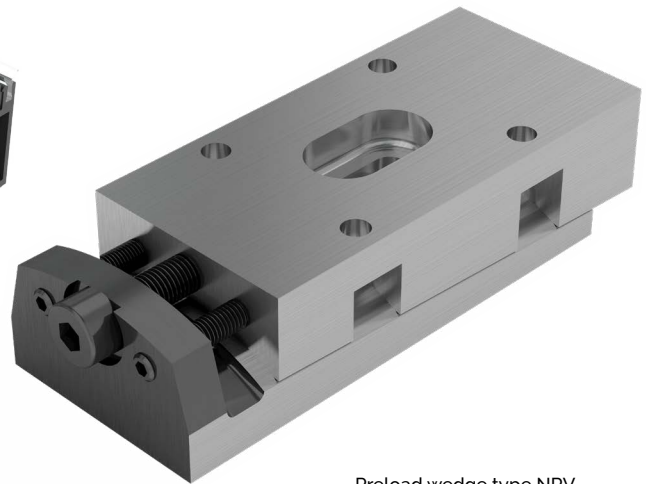

Preload wedge type NRV

This roller recirculating unit is designed for medium to heavy loads. Solutions to demanding applications can be created using NRT, NRV, and suitable guideways.

Advantages/benefits of the NRT

- Two independent tracks, the small amount of roller play and the optimal ratio of roller length and roller diameter are responsible for minimal lateral forces.
- The large number of rollers and the optimised roller run-ins are responsible for minimal travel pulsation and a low coefficient of rolling friction
- High degree of rigidity thanks to three-point support on the rear
- Protected roller return
- Double-lipped wipers on each side
- Can also be supplied matched as an option, sorted within 5µm

Advantages/benefits of the preload wedge NRV

This preload wedge is used for setting preload. The NRV with its concave and convex supporting surfaces is also able to even out minor angular errors and deformations in the connecting structure.

Benchmark data

Supporting structure

- Hardened and ground with high precision

Materials

- Supporting structure made of through hardened tool steel, hardness 58 – 62 HRC
- Rolling element made of through hardened roller bearing steel, hardness 58 – 64 HRC
- Transmission parts and wipers made of plastic

Speed

- 1 m/s

Acceleration

- 50 m/s²

Operating temperatures

- -40° C to +80° C

6 Recirculating unit

Dimensions and load capacities of type NRT

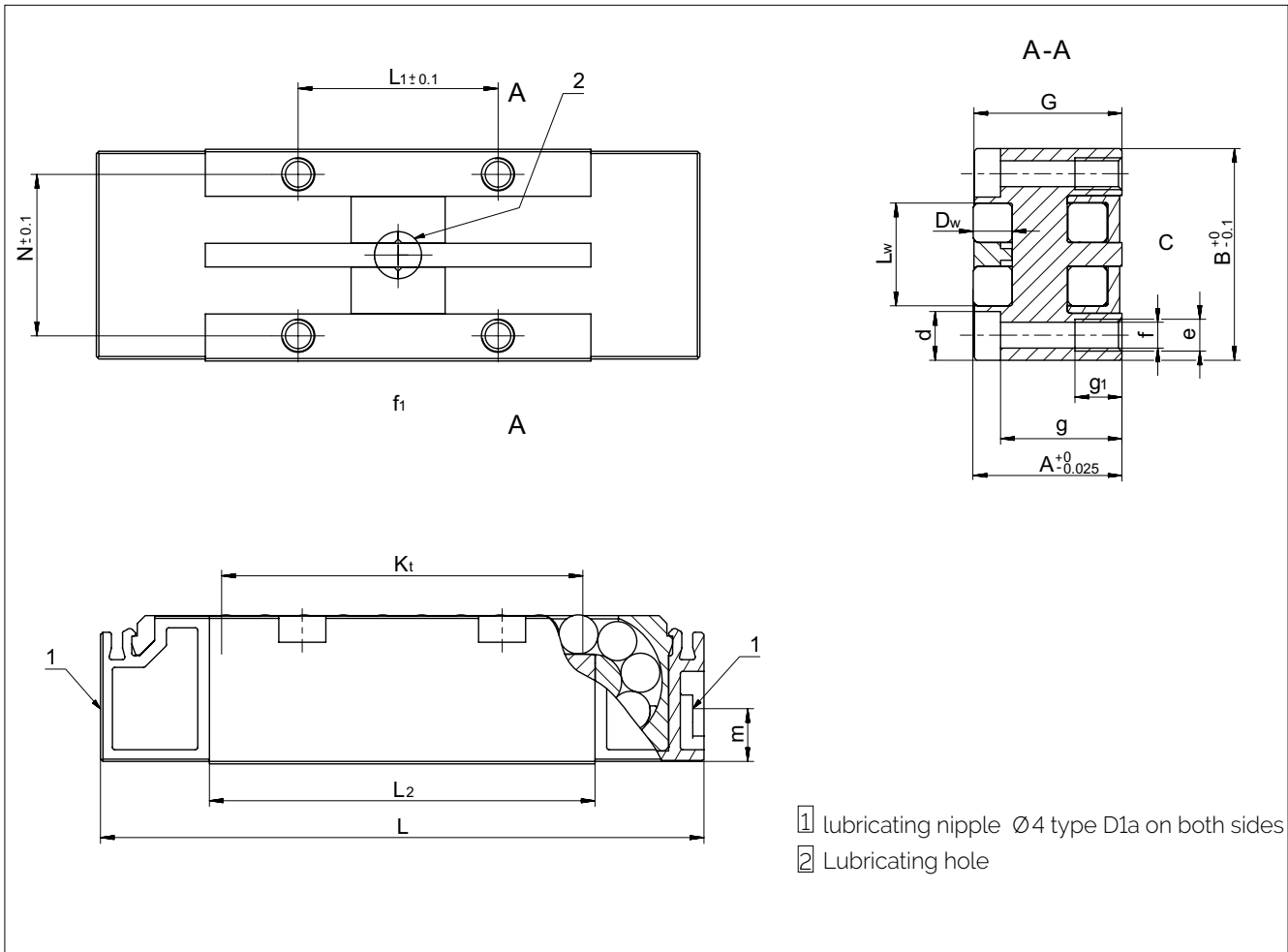

Recirculating unit type NRT

| Type and size | Weight in g | A | B | Dw | G | K_t | L | L_1 | L_2 | L_w | N | d | e | f | f_1 | g | g_1 | m | C in N | Options (see chapter 8) |
|---------------|-------------|----|----|----|-------|-------|-----|-------|-------|-------|------|----|----|-----|-------|------|-------|------|---------|-------------------------|
| NRT 19077 | 185 | 19 | 27 | 5 | 18.85 | 45 | 77 | 25.5 | 49.2 | 13 | 20.6 | 6 | M4 | 3.3 | 6 | 15.5 | 6 | 5.3 | 43'000 | GP ZS |
| NRT 26111 | 570 | 26 | 40 | 7 | 25.85 | 70 | 111 | 44 | 75.6 | 19 | 30 | 8 | M6 | 5 | 9 | 20 | 10 | 10.3 | 98'000 | GP ZS |
| NRT 26132 | 721 | | | | | 91 | 132 | 68 | 96.6 | | | | | | | | | | 120'000 | GP ZS |
| NRT 38144 | 1'390 | 38 | 52 | 10 | 37.8 | 90 | 144 | 51 | 96.8 | 26 | 41 | 11 | M8 | 6.8 | 11 | 29 | 14 | 14.5 | 181'000 | GP ZS |

6 Recirculating unit

Dimensions and load capacities of type NRV

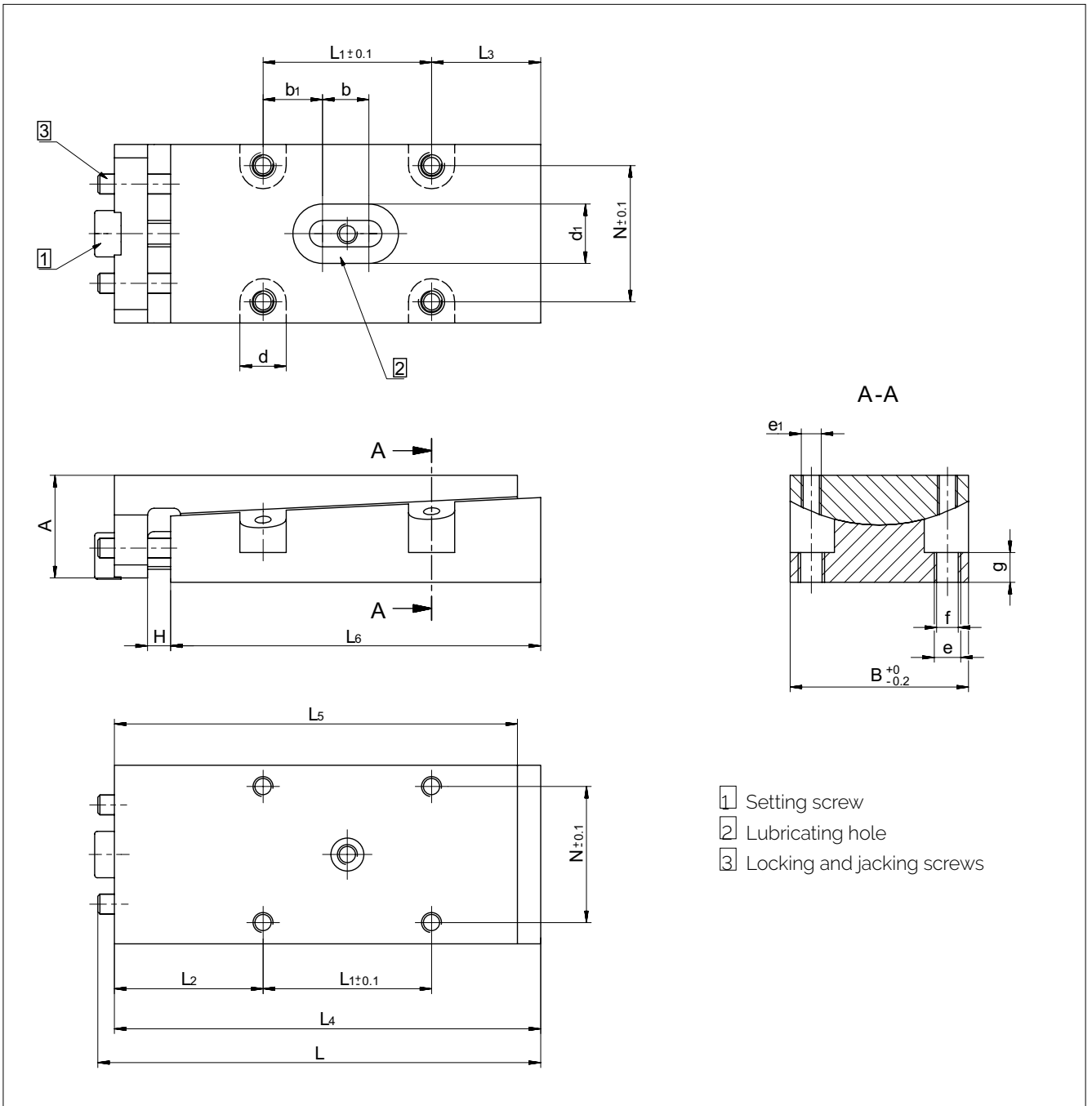

Preload wedge NRV

| Type and size | Weight in g | A | B | H max. | L max. | L ₁ | L ₂ | L ₃ | L ₄ max. | L ₅ | L ₆ | N | b | b ₁ | d | d ₁ | e | e ₁ | f | g |
|---------------|-------------|----|----|--------|--------|----------------|----------------|----------------|---------------------|----------------|----------------|-----|----|----------------|----|----------------|----|----------------|-----|-----|
| NRV 19077 | 195 | 16 | 27 | 7 | 72 | 25.5 | 22.5 | 16.5 | 68 | 61 | 56 | 206 | 7 | 9 | 7 | 9 | M4 | M3 | 3.3 | 4.5 |
| NRV 26111 | 670 | 25 | 40 | 8 | 105 | 44 | 29 | 21 | 98 | 90 | 83 | 30 | 9 | 175 | 8 | 11 | M6 | M4 | 5 | 8 |
| NRV 26132 | 837 | | | | 126 | 68 | 27.5 | 19.5 | 119 | 111 | 104 | | | | | | | | | |
| NRV 38144 | 1'300 | 30 | 52 | 8 | 130 | 51 | 37.5 | 28.5 | 121 | 113 | 105 | 41 | 10 | 20.5 | 11 | 14 | M8 | M6 | 6.8 | 8 |

7 Options for linear guideways

7.1 Quality classes (SQ and SSQ)

The run and positioning accuracy of an application depends directly on the geometric precision of the guideway, its careful alignment, as well as the precision and stiffness of the surrounding construction.

Depending upon the application different levels of accuracy are required. SCHNEEBERGER linear guideways are available in three quality classes to address a variety of applications:

| | | |
|-----|-----------------------|--|
| NQ* | Normal quality | Represents normal requirements in mechanical engineering |
| SQ | Special quality | In case of very stringent requirements |
| SSQ | Super special quality | In case of the most stringent requirements |

Note:

*NQ represents standard quality and is not subsequently listed as an order code

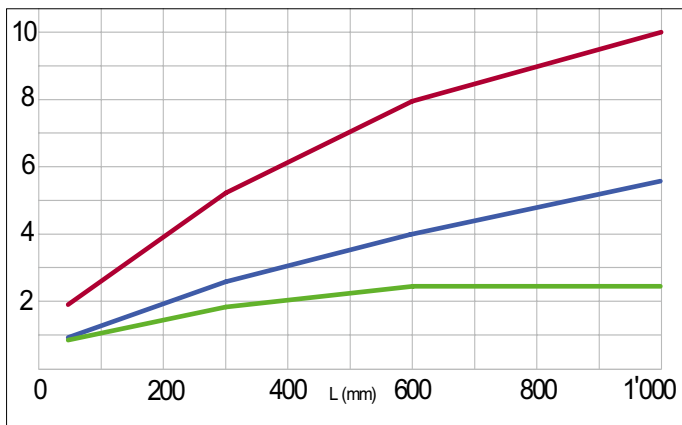
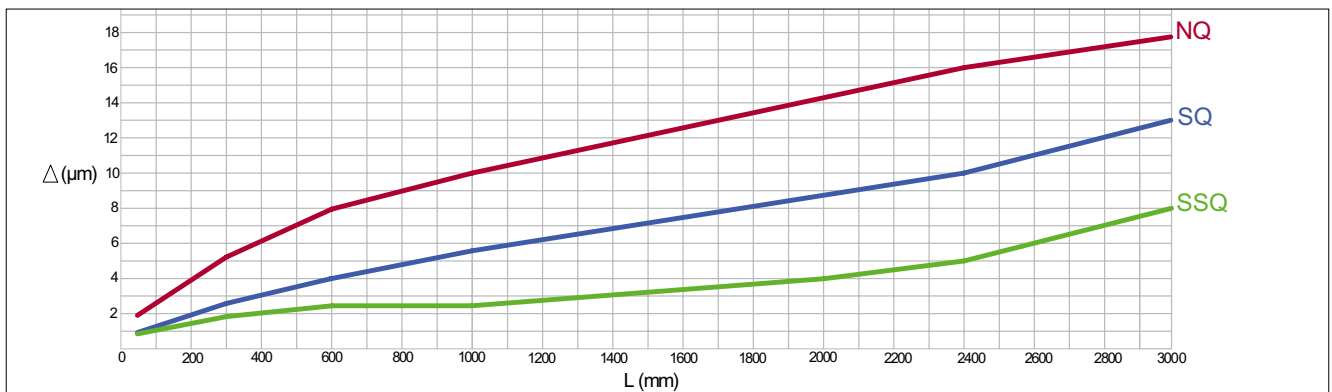

The corresponding tolerance values (Δ) for parallelism of the running surfaces in relation to the reference and locating surfaces can be seen in the diagram below.

In terms of the quality classes SQ and SSQ the following limitations technically exist:

- Max. lengths according to the table „Dimensions and load capacities“ of the respective product.
- Coatings (see chapter 7.6 and 7.7).

7.2 Guideways made of corrosion-resistant steel (RF)

For certain applications such as, for example, medical technology, food industry or in a vacuum, the guide rails can be made of corrosion-resistant steel.

Notes:

- The max. rail length in normal quality as well as in options SQ and SSQ is limited (see „dimensions and load capacities“ of the respective product).
- The hardness of the steel reduces compared with tool steel to min. 54 HRC, which should be taken into account in the food calculation.

7 Options for linear guideways

7.3 Run-ins rounded (EG)

Overrunning cages are expedient to used if a short table is to be moved on a long guideway track. As a result the upper part is at any time supported over its entire length, which has a positive effect on the load carrying capacity and rigidity.

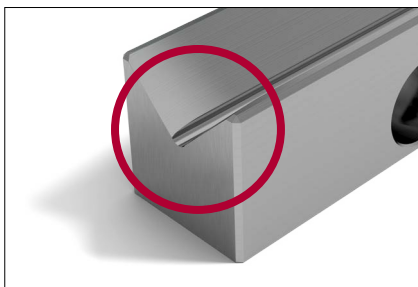
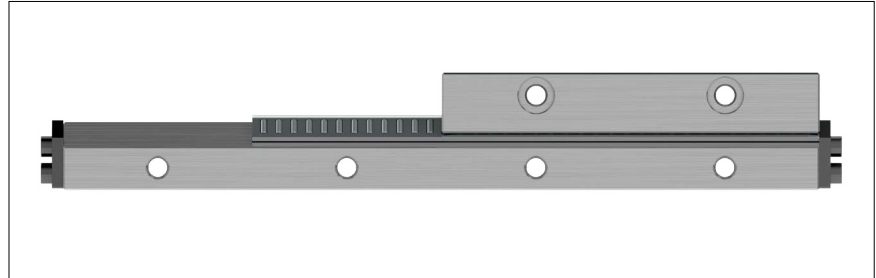

So that the cage run-in causes as little pulsation as possible, the short rails are provided with rounded run-ins. The run-ins are ground following manufacture of the guideway track.

Note:

On rare occasions (e.g. under very high preload), in spite of rounded run-ins the pulsation of the overrunning cage can have a disruptive effect on the application. This phenomenon can be largely eliminated by taking appropriate measures (on request).

7.4 Multi-part linear guideways (ZG)

Is the desired overall length of the guideway is greater than the maximum length listed in this catalogue, individual rails can be ground together. The offset between the individual guideway tracks for this is max. 0.002 mm. The length tolerance L is within +/- 2 mm.

During installation it is important to pay attention to the numbering at the butt joint.

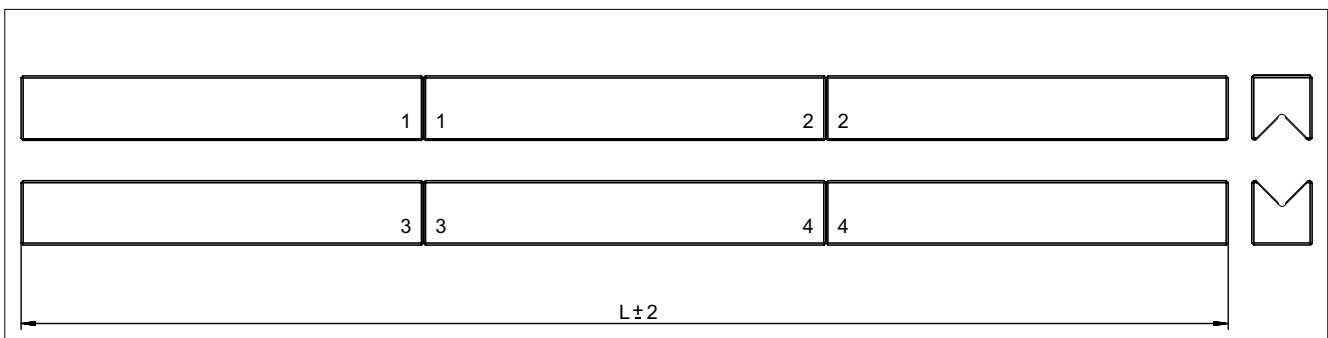

7 Options for linear guideways

7.5 Height-matched guideways (HA and EHA)

Height-matched guideways (HA)

The height difference between two linear guideway pairs (A1 and A2) is 0 mm to 0.3 mm as standard. This difference can be too large depending on the application. For height-matched guideways, the H dimensions of the linear guideways (H1 to H3 and H2 to H4) are measured and sorted so that the height difference of both linear guideway pairs (A1 and A2) can be reduced to a maximum of 0 mm to 0.02 mm. In addition, the guideways are numbered the same in pairs. This numbering is consecutive for multiple guideway pairs.

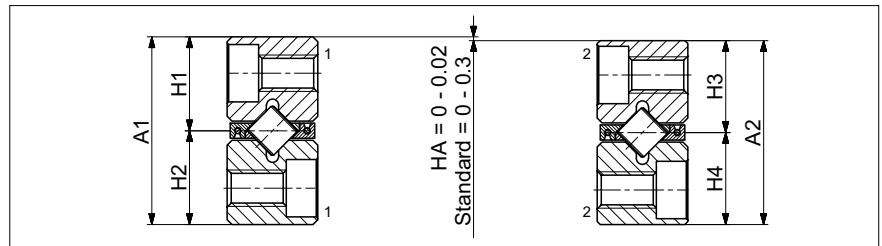

E dimension of height-matched guideways (EHA)

The width difference between two linear guideways (B21 to B22) is 0 mm to 0.02 mm as standard. This difference can be too large depending on the application. For the E dimensions of height-matched guideways, the E dimensions of the linear guideways (E1 to E3 and E2 to E4) are measured and sorted so that the width difference of both linear guideway pairs (B21 and B22) can be reduced to a maximum of 0 mm to 0.002 mm. In addition, the guideways are numbered the same in pairs. This numbering is consecutive for multiple guideway pairs.

Note: EHA option only available up to size 6

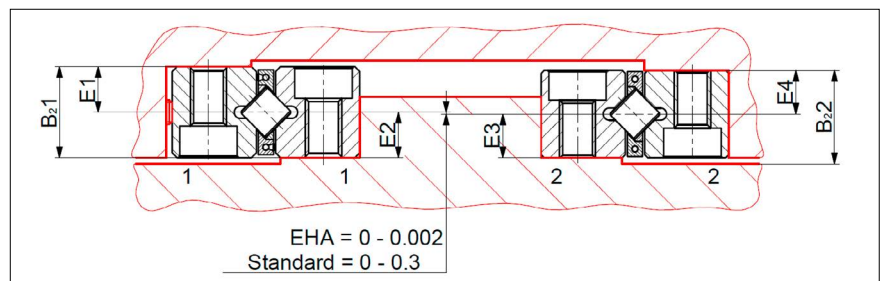

7.6 DURALLOY® coating (DU)

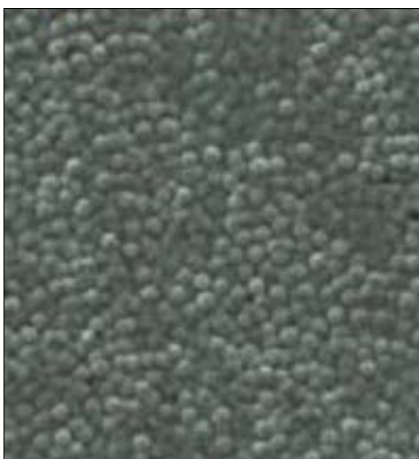

For applications for which corrosion protection and/or increased wear resistance of the surfaces is required, coating the guideways with DURALLOY® is recommended.

Technical information

- Max. rail length 3'000 mm
- Hardness HRC 64 - 74
- Coating thickness 2.5 - 4.0 µm
- Structure "Pearlescent" (see figure)
- Vacuum-compatible 10⁻⁷ mbar

The advantages of DURALLOY®

- Increased wear resistance
- Corrosion protection
- The pearl structure acts as a lubricant reservoir
- Good emergency running characteristics
- Protection from abrasive corrosion
- High degree of chemical resistance
- Cleanroom compatible
- FDA approved

Notes:

- The ZG special versions (multi-part linear guideway) and the maximum quality grade SSQ are not possible.
- Special quality SQ only on request

7.7 DryRunner coating (DR and DRC1)

Without lubrication, the running surfaces of linear guideways are completely destroyed after only 10,000 revolutions.

A guideway coated with DryRunner allows for more than 100 million revolutions without lubrication and thus a service life lubrication that is 10,000 times longer. In a vacuum, an unlubricated guideway coated with DryRunner allows more than 50 million revolutions.

To achieve outstanding running performance, we recommend the DryRunner coating in combination with minimal lubrication using a common lubricant.

Technical information

| Area of use | Air | Vacuum (bis 10^{-7} mbar) |
|-----------------------------|---|--------------------------------|
| Order code | DR | DRC1 |
| Film thickness | 15 - 3.0 μm | 10 - 2.0 μm |
| Operating temperature | -40°C - 80°C (up to 120 °C at short intervals) | -40°C - 80°C |
| Film Hardness | 8-12 HIT [GPa] | 12-15 HIT [GPa] |
| Max. length of the guideway | 900 mm | 380 mm |

- The coating is only applied to the running surfaces. From a production standpoint, it is possible to coat other exterior surfaces but not the supporting and locating surface of the guideway.
- DryRunner does not provide any protection against corrosion. If corrosion-resistant guideways are required, the guideway must be ordered in a rust-resistant material (RF) or with a Duralloy coating (DU).

The advantages of DryRunner

- Good emergency running properties insufficient lubrication
- Suitable for applications in air or vacuum
- Minimal wear due to abrasion
- High chemical resistance

Notes

- DryRunner permits operation with minimal lubrication.
- We recommend using the FORMULA-S cage control (KS) (see section 7.8).
- The special versions of the multi-part linear guideway ZG and the quality class SSQ are not possible. Quality class SQ on request (see section 7.4 and 7.1).

7 Options for linear guideways

7.8 Cage control FORMULA-S (KS)

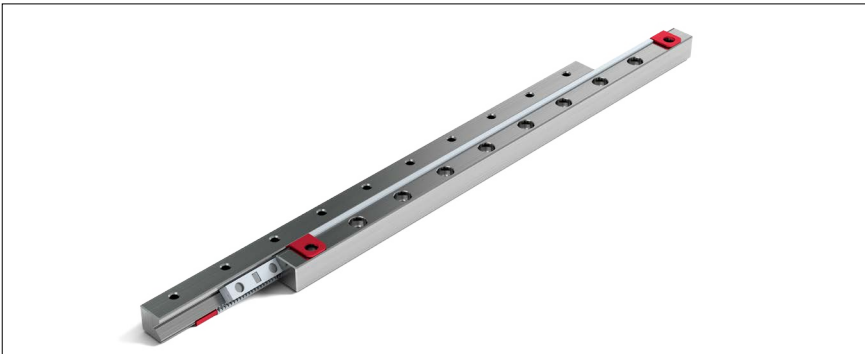

In every linear guideway the cage can be shifted from the centre along the longitudinal axis. Cage creep reduces the optimal load distribution and requires a correct stroke to return the cage to a centered position. The correction stroke requires a large expense of energy.

The causes of cage creep

- High accelerations and speeds
- Vertical installation of the guideway
- Uneven load distribution
- Protruding cage
- Different heat expansion coefficients
- Design and installation (lacking rigidity and/or accuracy of the connecting structure)

The benefits of FORMULA-S

- No cage slipping and thus consistent load conditions
- Avoids correction strokes
- No force required for cage reset
- Accelerations up to 300 m/s² (30 g)
- speed 1 m/s
- Easy to install and/or uninstall
- Extended service life
- Vacuum-compatible up to 10⁻⁷ mbar

Suitable for the following guideways

- RN 3, RN 4 and RN 6
- RNG 4, RNG 6 and RNG 9

FORMULA-S meets the requirements fully in respect of productivity and cost-effectiveness. It is very robust and consists of only a few components.

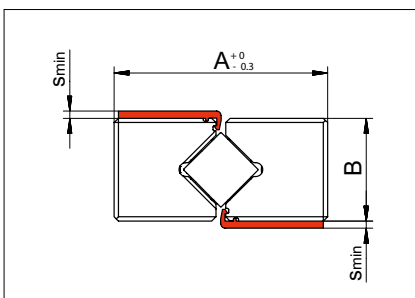
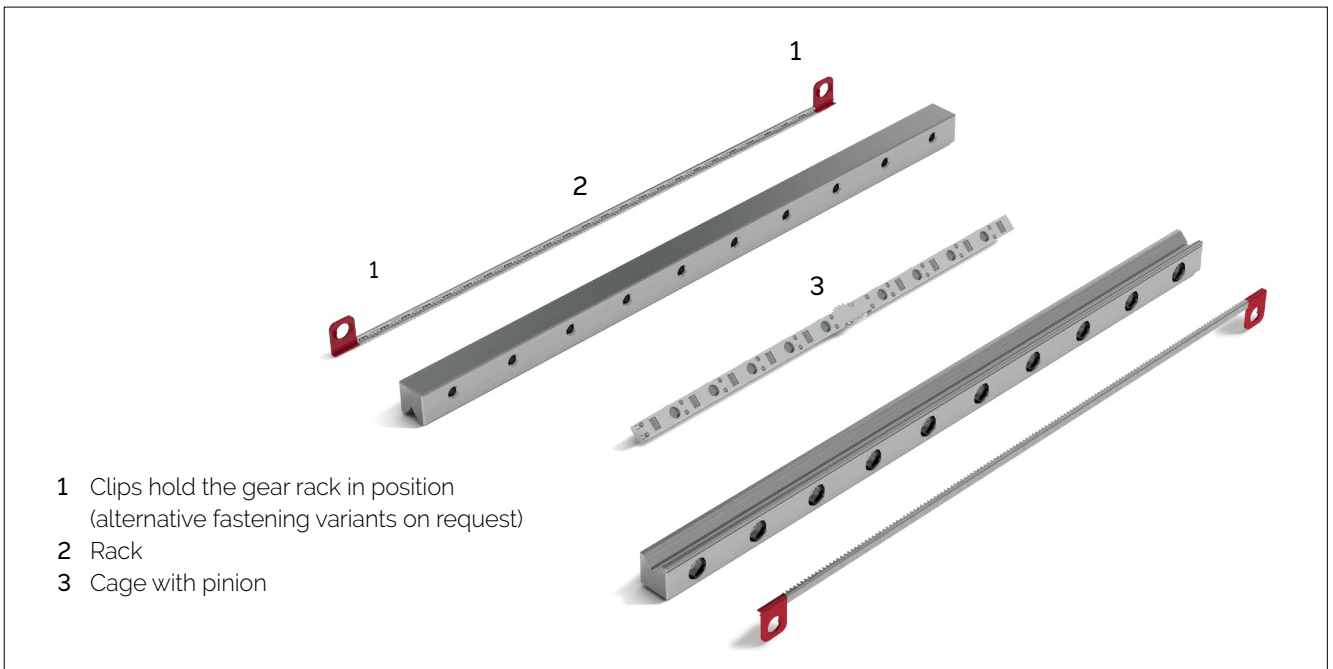

Connecting structure

In the case of the connecting structure, the thickness S_{min} should be taken into account. The remaining dimensions correspond to the guideways RN and RNG (see chapter 5, dimensions and load capacities).

7 Options for linear guideways

7.9 Cage control for N/O and M/V guideways (KZST)

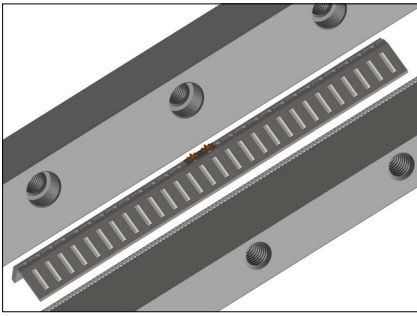

The needle guideways of type N/O and M/V can be fitted with a cage control which ensures that process security is significantly increased. The causes and effects of cage creep are set out in chapter 7.8.

The benefits and advantages

- Perfect load distribution
- Avoids correction strokes
- No force required for cage reset
- Accelerations up to 200 m/s^2 (20 g)
- Max. speed 1 m/s
- Extended service life

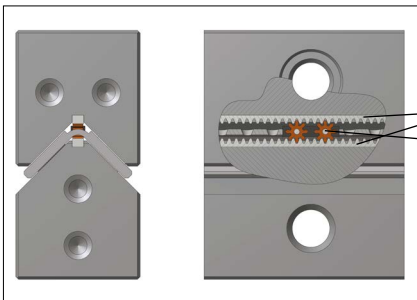

This type of cage control fully meets the requirements in terms of productivity and cost-effectiveness. It is very robust, has a simple structure and consists of only a few components:

- A A gear rack made of tool steel per guide rail
- B Two pinions made of tool steel per cage

7.10 Fixing Hole Variants (V, G, or D)

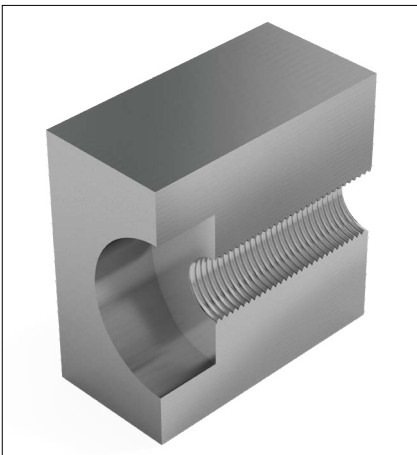

The SCHNEEBERGER standard

Most SCHNEEBERGER guideways have a counter bore with threading as standard. This is not suitable for the guideways of type M/V (variant V). This design supports the use of a tapped fixing hole as well as the through fixing hole. The dimensions can be seen in the respective product specifications (chapter 5).

7 Options for linear guideways

Special versions type V (standard for linear guideway of type M/V)

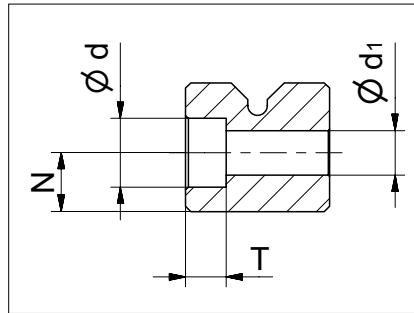
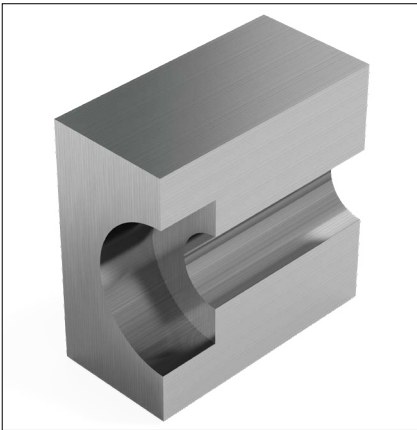

Dimensions for R-guideways

| Type | N | $\varnothing d$ | T | $\varnothing d_1$ |
|--------------------|-----|-----------------|------|-------------------|
| R 1 | 18 | 3 | 14 | 165 |
| R 2 | 25 | 4.4 | 2 | 255 |
| R 3 | 3.5 | 6 | 32 | 3.5 |
| R 6 | 6 | 9.5 | 52 | 5.5 |
| R 9 | 9 | 10.5 | 62 | 6.5 |
| R 12 | 12 | 13.5 | 82 | 8.5 |
| R 15 ¹⁾ | 14 | 16.5 | 10.2 | 10.5 |
| R 18 ¹⁾ | 18 | 18.5 | 12.2 | 12.5 |
| R 24 ¹⁾ | 24 | 22.5 | 14.2 | 14.5 |

Dimensions for RN-guideways

| Type | N | $\varnothing d$ | T | $\varnothing d_1$ |
|---------------------|-----|-----------------|------|-------------------|
| RN 3 | 3.5 | 6 | 3.2 | 3.5 |
| RN 4 | 4.5 | 8 | 4.1 | 4.5 |
| RN 6 | 6 | 9.5 | 5.2 | 5.5 |
| RN 9 | 9 | 10.5 | 6.2 | 6.5 |
| RN 12 ¹⁾ | 12 | 13.5 | 8.2 | 8.5 |
| RN 15 ¹⁾ | 14 | 16.5 | 10.2 | 10.5 |
| RN 18 ¹⁾ | 18 | 18.5 | 12.2 | 12.5 |
| RN 24 ¹⁾ | 24 | 22.5 | 14.2 | 14.5 |

Dimensions for RNG-guideways

| Type | N | $\varnothing d$ | T | $\varnothing d_1$ |
|----------------------|-----|-----------------|-----|-------------------|
| RNG 4 | 3.5 | 6 | 3.2 | 3.5 |
| RNG 6 | 5 | 7 | 3.2 | 4 |
| RNG 9 | 6 | 8.5 | 4.2 | 4.8 |
| RNG 12 | 8 | 12 | 6.2 | 7 |
| RNG 15 ¹⁾ | 10 | 15 | 8.2 | 9 |
| RNG 20 ¹⁾ | 12 | 18 | 11 | 10.5 |

Dimensions for RNG guideways with a cage control system (KS)

| Type | N | $\varnothing d$ | T | $\varnothing d_1$ |
|----------|-----|-----------------|-----|-------------------|
| RNG 4-KS | 3.5 | 6 | 3.2 | 3.5 |
| RNG 6-KS | 5 | 7.8 | 3.5 | 3.8 |
| RNG 9-KS | 6 | 8.5 | 4.2 | 4.8 |

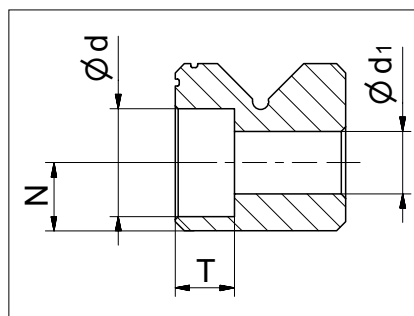

Dimensions for N/O-guideways

| Type | N | $\varnothing d_1$ | T | $\varnothing d_2$ |
|-----------|----|-------------------|------|-------------------|
| N/O 62015 | 6 | 9.5 | 5.2 | 5.5 |
| N/O 92025 | 9 | 10.5 | 6.2 | 6.8 |
| N/O 2025 | 10 | 13.5 | 8.2 | 8.5 |
| N/O 2535 | 12 | 16.5 | 10.2 | 10.5 |
| N/O 3045 | 14 | 18.5 | 12.2 | 12.5 |
| N/O 3555 | 14 | 18.5 | 12.2 | 12.5 |

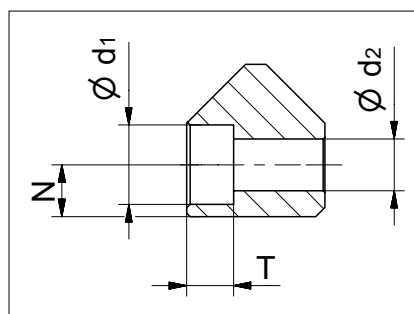
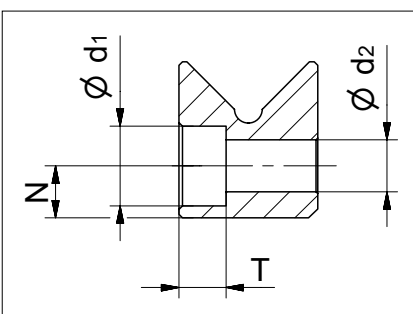

¹⁾ R 15, R 18, R 24, RN 18, RN 24, RNG 15, and RNG 20 are only available upon request

7 Options for linear guideways

Special versions type G

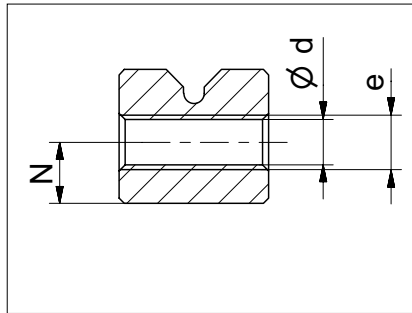
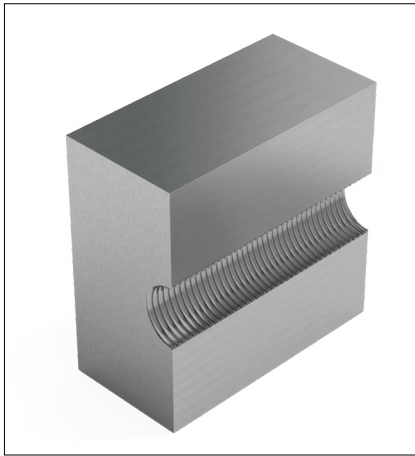

Dimensions for R-guideways

| Type | N | e | Ø d |
|--------------------|-----|-----|------|
| R 1 | 18 | M2 | 165 |
| R 2 | 25 | M3 | 255 |
| R 3 | 3.5 | M4 | 3.3 |
| R 6 | 6 | M6 | 5.2 |
| R 9 | 9 | M8 | 6.8 |
| R 12 | 12 | M10 | 8.5 |
| R 15 ¹⁾ | 14 | M12 | 10.5 |
| R 18 ¹⁾ | 18 | M14 | 12.5 |
| R 24 ¹⁾ | 24 | M16 | 14.5 |

Dimensions for RN-guideways

| Type | N | e | Ø d |
|---------------------|-----|-----|------|
| RN 3 | 3.5 | M4 | 3.3 |
| RN 4 | 4.5 | M5 | 4.3 |
| RN 6 | 6 | M6 | 5.2 |
| RN 9 | 9 | M8 | 6.8 |
| RN 12 | 12 | M10 | 8.5 |
| RN 15 ¹⁾ | 14 | M12 | 10.5 |
| RN 18 ¹⁾ | 18 | M14 | 12.5 |
| RN 24 ¹⁾ | 24 | M16 | 14.5 |

Dimensions for RNG-guideways

| Type | N | e | Ø d |
|----------------------|-----|-----|------|
| RNG 4 | 3.5 | M3 | 2.65 |
| RNG 6 | 5 | M4 | 3.3 |
| RNG 9 | 6 | M5 | 4.4 |
| RNG 12 | 8 | M8 | 6.8 |
| RNG 15 ¹⁾ | 10 | M10 | 8.5 |
| RNG 20 ¹⁾ | 12 | M12 | 10.5 |

Dimensions for N/O-guideways

| Type | N | e ₂ | Ø f ₃ |
|-----------|----|----------------|------------------|
| N/O 62015 | 6 | M6 | 5.2 |
| N/O 92025 | 9 | M8 | 6.8 |
| N/O 2025 | 10 | M10 | 8.5 |
| N/O 2535 | 12 | M12 | 10.5 |
| N/O 3045 | 14 | M14 | 12.5 |
| N/O 3555 | 14 | M14 | 12.5 |

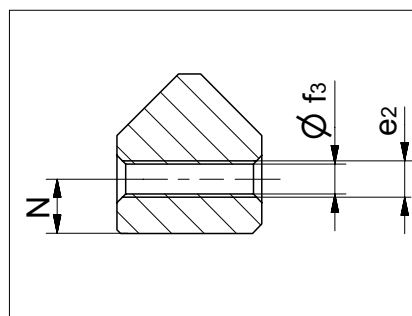
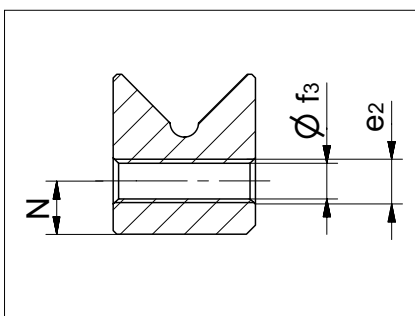

¹⁾ R 15, R 18, R 24, RN 18, RN 24, RNG 15, and RNG 20 are only available upon request

7 Options for linear guideways

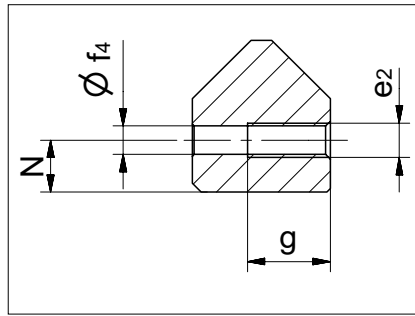
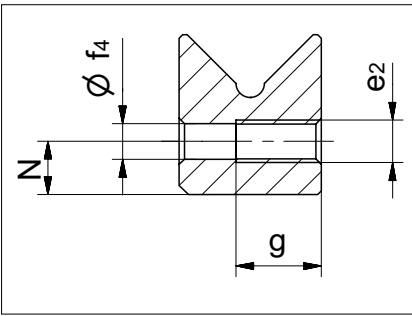
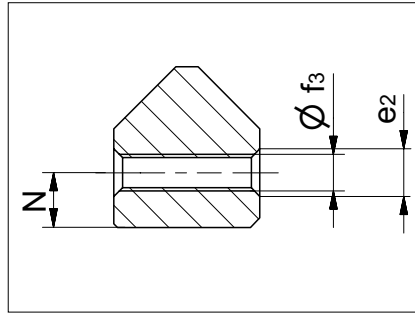
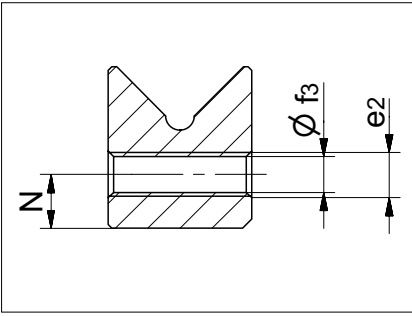

Dimensions for M/V-guideways

| Type | N | e ₂ | g | Ø f ₃ | Ø f ₄ |
|----------|----|----------------|----|------------------|------------------|
| M/V 3015 | 55 | M4 | - | 3.2 | - |
| M/V 4020 | 75 | M6 | - | 5.2 | - |
| M/V 5025 | 10 | M6 | 15 | 5.2 | 5 |
| M/V 6035 | 11 | M8 | 20 | 6.8 | 6.8 |
| M/V 7040 | 13 | M10 | 25 | 8.5 | 8.5 |
| M/V 8050 | 14 | M12 | 30 | 10.5 | 10.3 |

7 Options for linear guideways

Special versions type D

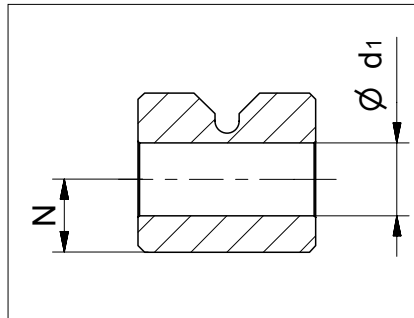
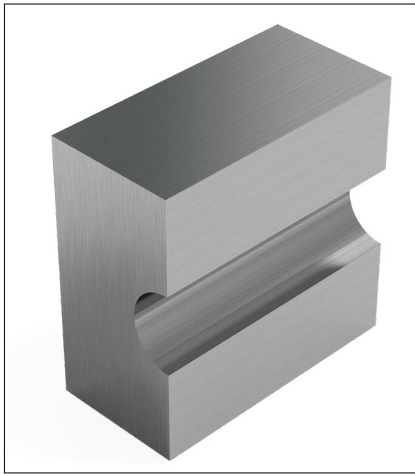

Dimensions for R-guideways

| Type | N | Ø d ₁ |
|--------------------|-----|------------------|
| R 1 | 18 | 165 |
| R 2 | 2.5 | 2.55 |
| R 3 | 3.5 | 3.5 |
| R 6 | 6 | 5.5 |
| R 9 | 9 | 6.5 |
| R 12 | 12 | 8.5 |
| R 15 ¹⁾ | 14 | 10.5 |
| R 18 ¹⁾ | 18 | 12.5 |
| R 24 ¹⁾ | 24 | 14.5 |

Dimensions for RN-guideways

| Type | N | Ø d ₁ |
|---------------------|-----|------------------|
| RN 3 | 3.5 | 3.5 |
| RN 4 | 4.5 | 4.5 |
| RN 6 | 6 | 5.5 |
| RN 9 | 9 | 6.5 |
| RN 12 | 12 | 8.5 |
| RN 15 ¹⁾ | 14 | 10.5 |
| RN 18 ¹⁾ | 18 | 12.5 |
| RN 24 ¹⁾ | 24 | 14.5 |

Dimensions for RNG-guideways

| Type | N | Ø d ₁ |
|----------------------|-----|------------------|
| RNG 4 | 3.5 | 3.5 |
| RNG 6 | 5 | 4 |
| RNG 9 | 6 | 4.8 |
| RNG 12 | 8 | 7 |
| RNG 15 ¹⁾ | 10 | 9 |
| RNG 20 ¹⁾ | 12 | 10.5 |

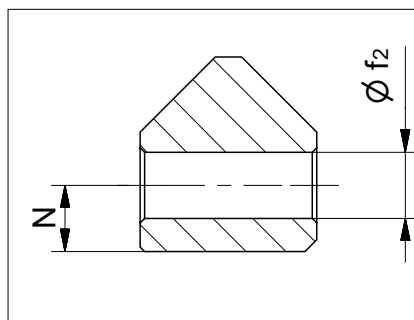
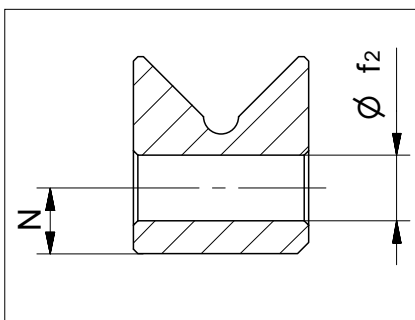

Dimensions for N/O-guideways

| Type | N | Ø f ₂ |
|-----------|----|------------------|
| N/O 62015 | 6 | 5.5 |
| N/O 92025 | 9 | 6.5 |
| N/O 2025 | 10 | 8.5 |
| N/O 2535 | 12 | 10.5 |
| N/O 3045 | 14 | 12.5 |
| N/O 3555 | 14 | 12.5 |

Dimensions for M/V-guideways

| Type | N | Ø f ₂ |
|----------|-----|------------------|
| M/V 3015 | 5.5 | 5.3 |
| M/V 4020 | 7.5 | 7.5 |
| M/V 5025 | 10 | 7.5 |
| M/V 6035 | 11 | 10 |
| M/V 7040 | 13 | 12.5 |
| M/V 8050 | 14 | 14 |

¹⁾ R 15, R 18, R 24, RN 18, RN 24, RNG 15 und RNG 20 sind nur auf Anfrage erhältlich

8 Recirculating unit options

8.1 Matched recirculating units (GP)

SK, SKD, SKC, SR

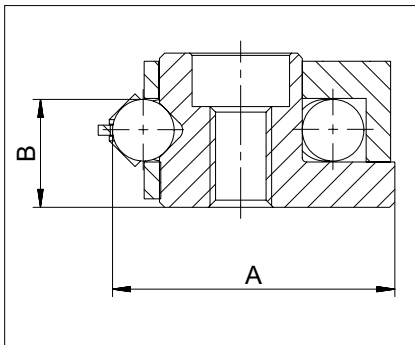

If two or more recirculating units are arranged next to or behind one another, they need to be ordered (matched in pairs) with the add-on designation GP.

| Type | Manufacturing tolerances in mm | | Group tolerances in μm within pairs | |
|-------------------------|--------------------------------|----------|--|---|
| | A | B | A | B |
| SK 1, 2 | 0/-0.1 | +/-0.005 | 2 | 2 |
| SK 3, 6, 9, 121) | 0/-0.1 | +/-0.005 | 3 | 3 |
| SKD 6, 9, 121) | 0/-0.1 | +/-0.005 | 3 | 3 |
| SKC 6, 9 | 0/-0.1 | +/-0.005 | 3 | 3 |
| SR 2 | 0/-0.1 | +/-0.005 | 2 | 2 |
| SR 3, 6, 9, 121) | 0/-0.1 | +/-0.005 | 3 | 3 |

The types in bold are standard. The types in size 12 are available on request

Markings:

The recirculating units in the same group are designated with a number, i.e. the same number corresponds to the exact same tolerance group.

NRT

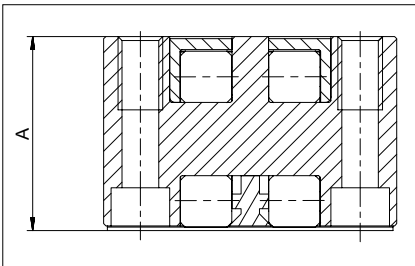

| Type | Manufacturing tolerance A | Sorts in μm | Markings |
|------|---------------------------|------------------------|----------|
| NRT | -0.025 | -20 to -25 | white |
| | | -15 to -20 | green |
| | | -10 to -15 | yellow |
| | | -5 to -10 | blue |
| | | 0 to -5 | red |

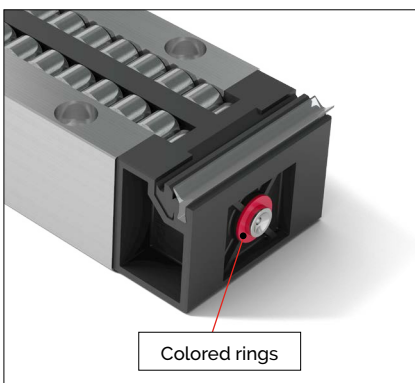

Markings:

Colored rings around the lube nipple mark the relevant tolerance group.

¹⁾ Types of size 12 are only available on request

8 Recirculating unit options

8.2 Centralised lubricating system (ZS) for recirculating units NRT

Connection variants

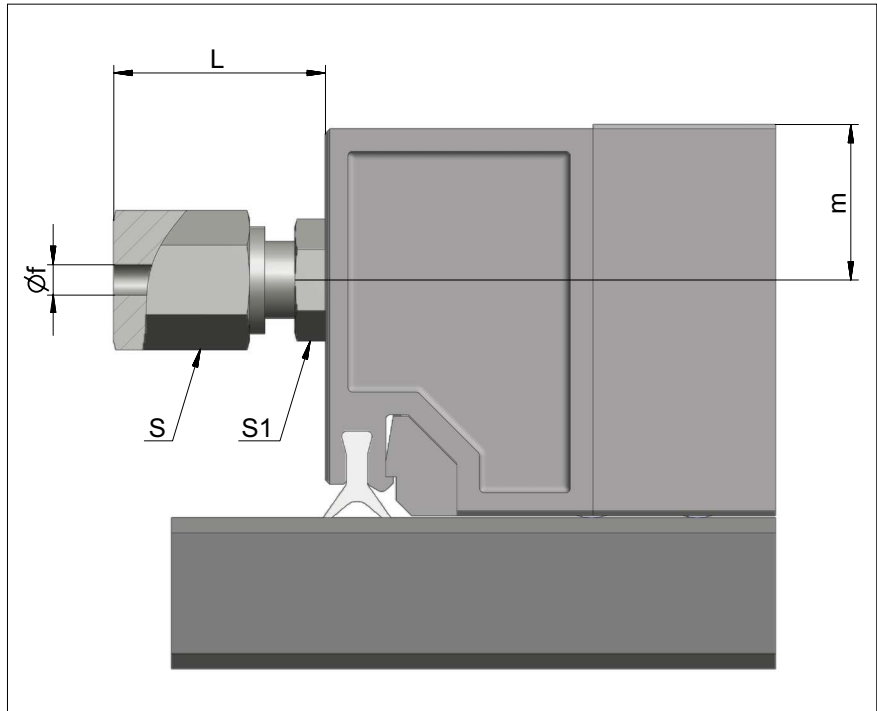

| Type | Size | L | f | m | Wrench size | |
|------------------------|------|----|---|------|-------------|----|
| | | | | | s | s1 |
| NRT 19077 | ZS-2 | 14 | 2 | 5.3 | 8 | 7 |
| | ZS-3 | 16 | 3 | | | |
| NRT 26111 NRT 26132 | ZS-2 | 14 | 2 | 10.3 | 8 | 7 |
| | ZS-3 | 16 | 3 | | | |
| | ZS-4 | 20 | 4 | | 10 | 8 |
| | ZS-5 | 20 | 5 | | | |
| | ZS-6 | 22 | 6 | | | |
| NRT 38144 | ZS-2 | 14 | 2 | 14.5 | 8 | 7 |
| | ZS-3 | 16 | 3 | | | |
| | ZS-4 | 20 | 4 | | 10 | 8 |
| | ZS-5 | 20 | 5 | | | |
| | ZS-6 | 22 | 6 | | | |

9 Linear guideways standard parameters

9.1 Tolerance of the supporting surface to the track

In addition to the previously mentioned geometric precision as set out in chapter 7.1, SCHNEEBERGER guideways are also manufactured to the dimensions of the supporting surface in relation to the track within a very tight tolerance ($\pm 0.005\text{mm}$).

Advantages:

- Interchangeability is guaranteed at all times
- In most cases additional matching of the guideways is surplus to requirement

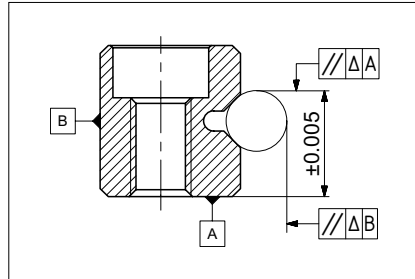

Type R, RN and RNG

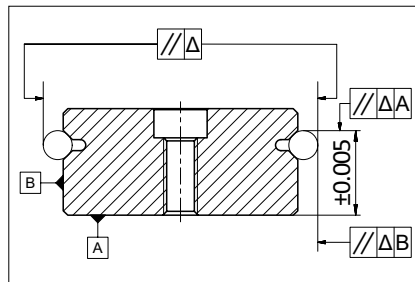

Type RD

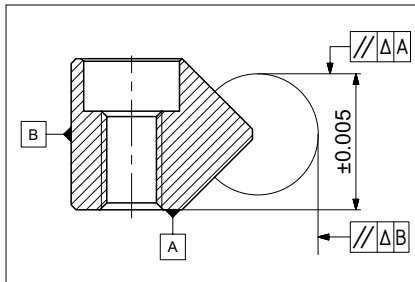

Type N/O and M/V

9 Linear guideways standard parameters

9.2 Length tolerances and distances between fixing holes

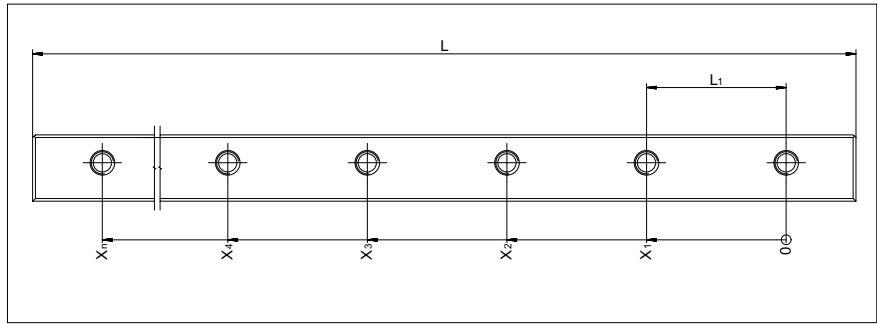

| | | |
|------------|--------------------------|---------------------------|
| Length | L ≤ 300 mm: | ±0.3 mm |
| Length | L > 300 mm: | ±0.1 % of L |
| Hole pitch | L _j : | ±0.3 mm |
| Mass | X _n ≤ 350 mm: | ±0.3 mm |
| Mass | X _n > 350 mm: | ±0.08 % of X _n |

The fixing holes are manufactured before the hardening process, which is why the length tolerances and spacings differ from the usual standards. The deviations can be offset using undercut fastening screws of type GD or GDN (see chapter 5) and/or by choosing a suitable hole (see chapter 7.10).

9.3 Operating temperatures

SCHNEEBERGER linear guideways can be used at operating temperatures from -40° C to +80° C. For brief periods temperatures up to +120° C are possible.

9.4 Speeds and accelerations

The following limit values apply for the standard designs:

| Product | Max. speed | Max. acceleration |
|---|------------|----------------------|
| Linear guideways R, RD, RN, RNG, N/O and M/V | 1 m/s | 50 m/s ² |
| Linear guideways RN and RNG with Cage control FORMULA-S | 1 m/s | 300 m/s ² |
| Linear guideways N/O and M/V with cage control | 1 m/s | 200 m/s ² |

9.5 Friction, running accuracy and smoothness

When manufacturing the linear guideways, SCHNEEBERGER places great value on a high level of smoothness. Transitions, run-ins and run-outs or the quality of the synthetic materials and synthetic composite cages are given top priority. This also applies in respect of the rolling elements used, which must satisfy the most stringent quality demands.

For guideways with cages under normal operating conditions a friction factor of 0.0005 to 0.0030 can be assumed.

10 Recirculating unit standard parameters

10.1 Operating temperatures

SCHNEEBERGER recirculating units can be used at operating temperatures from -40°C to $+80^{\circ}\text{C}$ (for brief periods temperatures up to $+120^{\circ}\text{C}$ are possible). For type SKC the temperature range is -150°C to $+200^{\circ}\text{C}$.

10.2 Speeds and accelerations

The following limit values apply for the standard designs:

| Product | max. speed | max. acceleration |
|---------------------|------------|---------------------|
| SK, SKD, SKC and SR | 2 m/s | 50 m/s ² |
| NRT | 1 m/s | 50 m/s ² |

10.3 Friction, running accuracy and smoothness

When manufacturing the recirculating units, SCHNEEBERGER places great value on a high level of smoothness. Transitions, run-ins and run-outs or the quality of the synthetic materials are given top priority. This also applies in respect of the rolling elements used, which must satisfy the most stringent quality demands.

For recirculating units under normal operating conditions a friction factor of 0.005 can be assumed.

The varied areas of application require different characteristics of linear guideways and recirculating units.

Various parameters and considerations are critical for product selection. These are described in detail below.

11.1 Linear guideways

Relationship between stroke H and length of the guideway L

If the stroke is below 400 mm, the following formula applies:

$$\frac{H}{L} \leq 0.7$$

If the stroke is above 400 mm, the following formula applies:

$$\frac{H}{L} \leq 1$$

L = Length of the linear guideway in mm
 H = Possible Stroke in mm

Calculating the cage length K

$$K \leq L - H_1$$

If the stroke is symmetrical, the following formula applies:

$$H = H_1 + H_2 = H_{12}$$

If the stroke is asymmetrical, the following formula applies:

$$H = H_1 + H_1 \quad H > H_1 + H_2 \quad H_{12} = H_1 + H_2$$

K = Cage length in mm
 L = Length of the linear guideway in mm
 H = Possible Stroke in mm
 H₁ = Large partial stroke in mm = H/2
 H₂ = Small partial stroke in mm = H/2
 H₁₂ = Effective partial stroke in mm

The stroke must be limited by means of stops on the table and not by the cages. The stops should preferably be fitted along the axis of symmetry of the guideways to avoid additional forces acting on the linear guideways.

Calculating the number of rolling elements (R_A) per cage

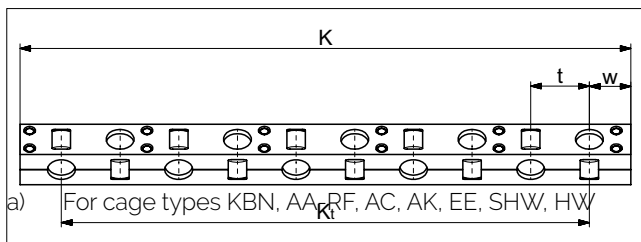

$$K = (R_A - 1) \cdot t + 2 \cdot w \Rightarrow R_A = \frac{K - 2 \cdot w}{t} + 1$$

or

$$R_A = \frac{K_t}{t} + 1$$

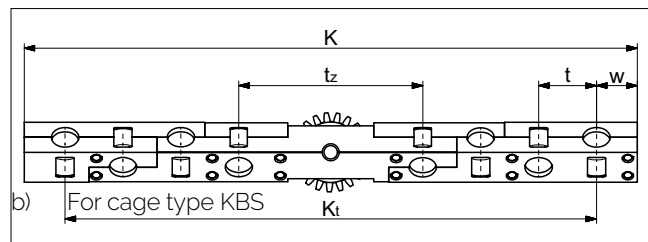

$$K = (R_A - 2) \cdot t + t_z + 2 \cdot w \Rightarrow R_A = \frac{K - (2 \cdot w + t_z)}{t} + 2$$

or

$$R_A = \frac{K_t - t_z}{t} + 2$$

K = Cage length in mm
 R_A = Total available rolling element per cage
 w = Distance from cage start to the middle of the first rolling element in mm
 t = cage division in mm
 K_t = Load-bearing length in mm
 t_z = Length of the middle section for the KBS cage

The relationship between the cage length K and the average guideway spacing Q

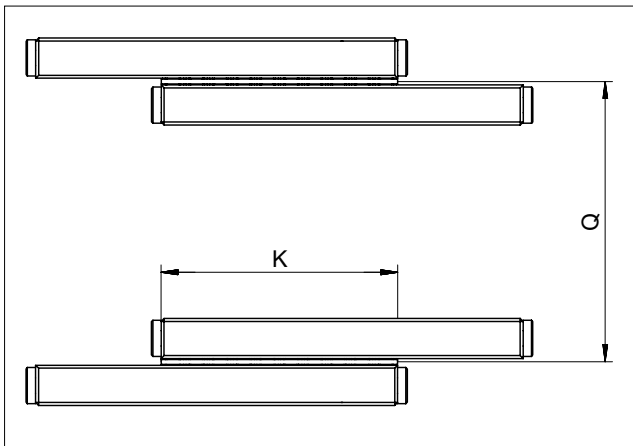

$$\frac{K}{Q} \geq 1$$

K = Cage length in mm
 Q = Average linear guideway spacing in mm

The maximum permissible installation ratio in the case of overrunning cages

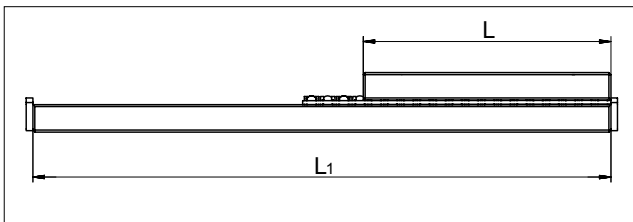

Overrunning cages are expedient if a short table is to be moved on a long guideway track. In each case the short rail for the guideway must have a rounded run-in (special version EG, see chapter 7.3) so that the overrunning cage causes as little pulsation as possible.

Not every cage is suitable for this application. The maximum cage overrun depends on the position of the rails and on the cage material.

Maximum permitted installation ratios L to L_1 :

- for fixed guideways 1 : 2
- for laid on guideways 1 : 4

Installation variants for linear guideways

There are four installation variants for linear guideways. The various linear guideways can be also used with wipers in the form of end pieces (a_1)*. In these four cases, the following length ratios result:

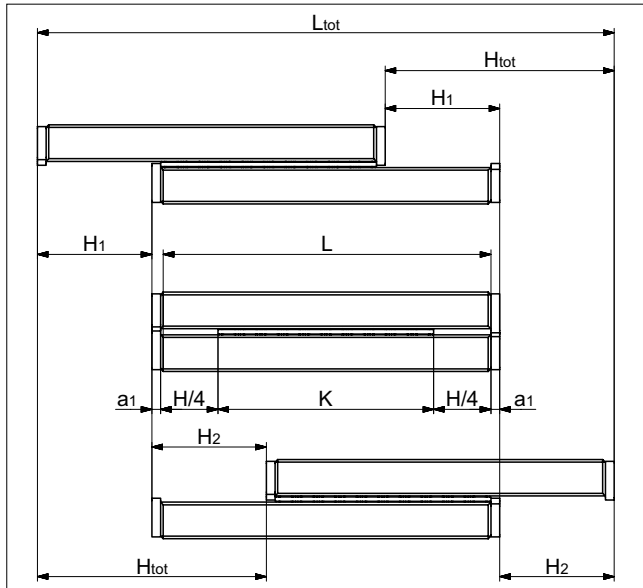

Variant 1

Linear guideway with:

- Equal length rails
- Symmetric / asymmetric stroke

a) Without end screws, end pieces, and end pieces with wipers

$$K \leq L - H_1$$

$$L_{tot} = L + H_1 + H_2$$

b) For end screws, end pieces, and end pieces with wipers**

$$K = L - H_1$$

$$L_{tot} = L + H_1 + H_2 + 2 \cdot a_1$$

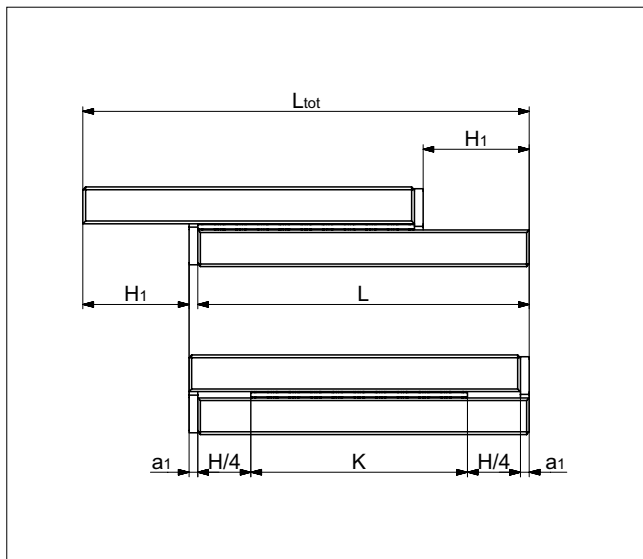

Variant 2

Linear guideway with:

- Equal length rails
- Unidirectional stroke

a) Without end screws, end pieces, and end pieces with wipers

$$K \leq L - H_1$$

$$L_{tot} = L + H_1$$

b) For end screws, end pieces, and end pieces with wipers**

$$K \leq L - H_1 - a_1$$

$$L_{tot} = L + H_1 + a_1$$

With this design, the linear guideways must be staggered to one another by the amount a_1 .

- K = Cage length in mm
- H = Possible Stroke in mm
- H₁ = Large partial stroke in mm = H/2
- H₂ = Small partial stroke in mm ≤ H/2
- L_{tot} = Effective partial stroke in mm
- L = Length in mm
- L₁ = Length in mm
- L_{tot} = Total length in mm
- a_n = Thickness of the end piece in mm

* a_1 end screws, end pieces, and end pieces with wipers, see chapter 5

** Wipers can influence the run characteristics of the linear guideways

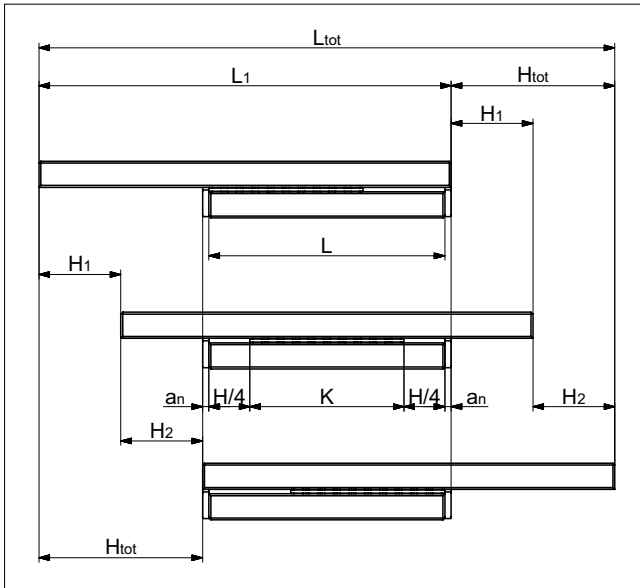

Variant 3

Linear guideway with:

- Unequal length rails
- Symmetric / asymmetric stroke
- Short rails attached

a) Without end screws, end pieces, and end pieces with wipers

$$K \leq L - H_1$$

$$L_{tot} = L + H_1 + H_2$$

b) For end screws, end pieces, and end pieces with wipers**

$$K \leq L - H_1 - 2 \cdot a_n$$

$$L_{tot} = L + H_1 + H_2$$

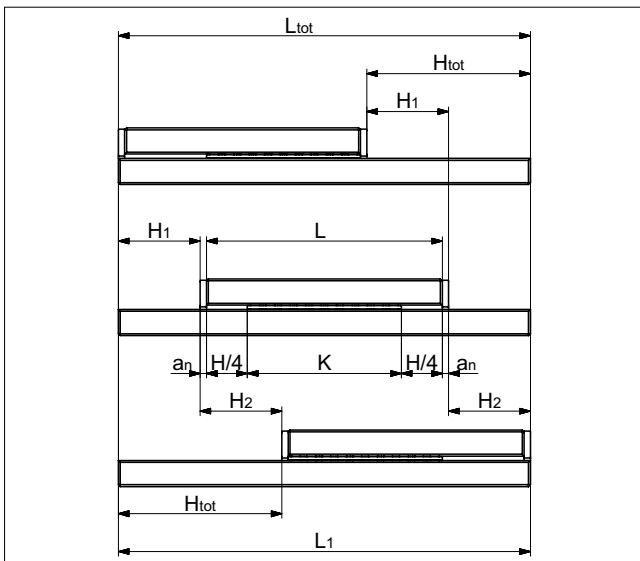

Variant 4

Linear guideway with:

- Unequal length rails
- Symmetric / asymmetric stroke
- Long rails attached

a) Without end screws, end pieces, and end pieces with wipers

$$K \leq L - H_1$$

$$L_{tot} = L + H_1 + H_2 \quad (\text{wenn } L \geq L_1 - H_{12})$$

$$L_{tot} = L_1 \quad (\text{wenn } L \geq L_1 - H_{12})$$

b) For end screws, end pieces, and end pieces with wipers**

$$K \leq L - H_1 - a_n$$

$$L_{tot} = L + H_1 + H_2 + 2 \cdot a_n \quad (\text{wenn } L \geq L_1 - H_{12})$$

$$L_{tot} = L_1 \quad (\text{wenn } L \geq L_1 - H_{12})$$

| | |
|------------------|------------------------------------|
| K | = Cage length in mm |
| H | = Possible stroke in mm |
| H ₁ | = Large partial stroke in mm = H/2 |
| H ₂ | = Small partial stroke in mm ≤ H/2 |
| H _{tot} | = Effective partial stroke in mm |
| L | = Length in mm |
| L ₁ | = Length in mm |
| L _{tot} | = Total length in mm |
| a _n | = Thickness of the end piece in mm |

* a_n end screws, end pieces, and end pieces with wipers, see chapter 5
 ** Wipers can influence the run characteristics of the linear guideways

11 Design

11.2 Recirculating units

When using recirculating units, theoretically there is not restriction in stroke. The stroke is only restricted by the length of the guide rails.

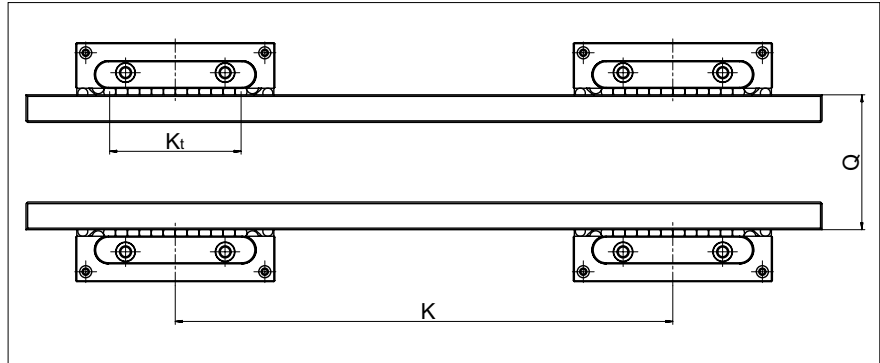

In terms of the spacing K between the recirculating units and the rail spacing Q , the following ratios are recommended as a guideline:

When using **one** recirculating unit per rail: $\frac{K_t}{Q} \geq 1$

When using **more than one** recirculating unit per rail: $\frac{K}{Q} \geq 1$

K = Spacing between the recirculating units in mm
 K_t = Load-bearing length in mm
 Q = Average rail spacing in mm

12 Load carrying capacity and service life

12.1 Basic principles

The load capacities are based on DIN ISO standard 14728 for roller-contact bearings.

In accordance with DIN, in most applications a permanent overall deformation of 0.0001 times the rolling element diameter can be permitted without adversely affecting the operating behavior of the bearing. This is referred to as the static capacity, C_0 . When designing a new application, we recommend the equivalent static load be in line with the dynamic load capacity (C) to avoid plastic deformation.

The dynamic loading capacity C is the load at which a nominal service life L of 100,000 meters of travel is achieved. It is important to note when calculating the service life that not only the load, which acts vertically on the guideway, should be taken into account but the load range of all acting forces and moments.

The service life corresponds to the travel distance in meters, which is travelled from a guideway. This is before the first sign of material fatigue occurs within the roller guideway elements. The nominal service life is achieved when 90 % of the guideways of identical construction reach or exceed the corresponding travel distances under normal operating conditions.

Critical for the dimensioning of the guideways are the loads occurring in the ratio with the dynamic loading capacity C .

Definition of service life

As previously mentioned, the dynamic loading capacity C_{100} is based on a service life of 100,000 meters. Other manufacturers frequently indicate the loading capacity C_{50} for a service life of 50,000 meters. The resulting load capacities from this are more than 20 % higher than specified in the DIN ISO standard.

Conversion examples

For balls

Convert load capacities in accordance with DIN ISO standard to C_{50} :

$$C_{50} = 1.26 \cdot C_{100}$$

Convert C_{50} load capacities in accordance with DIN ISO standard to:

$$C_{100} = 0.79 \cdot C_{50}$$

For rollers and needles

Convert load capacities in accordance with DIN ISO standard to C_{50} :

$$C_{50} = 1.23 \cdot C_{100}$$

Convert C_{50} load capacities in accordance with DIN ISO standard to:

$$C_{100} = 0.81 \cdot C_{50}$$

C_{50} = dynamic loading capacity C in N for 50,000 meters of travel distance
 C_{100} = dynamic loading capacity C in N for 100,000 meters of travel distance
 defined in accordance with DIN ISO standard

12 Load carrying capacity and service life

12.2 Short strokes

We talk about short stroke applications when a rolling element does not travel past the position of the next rolling element during a stroke.

A continuous lubricating film forms below the rolling element

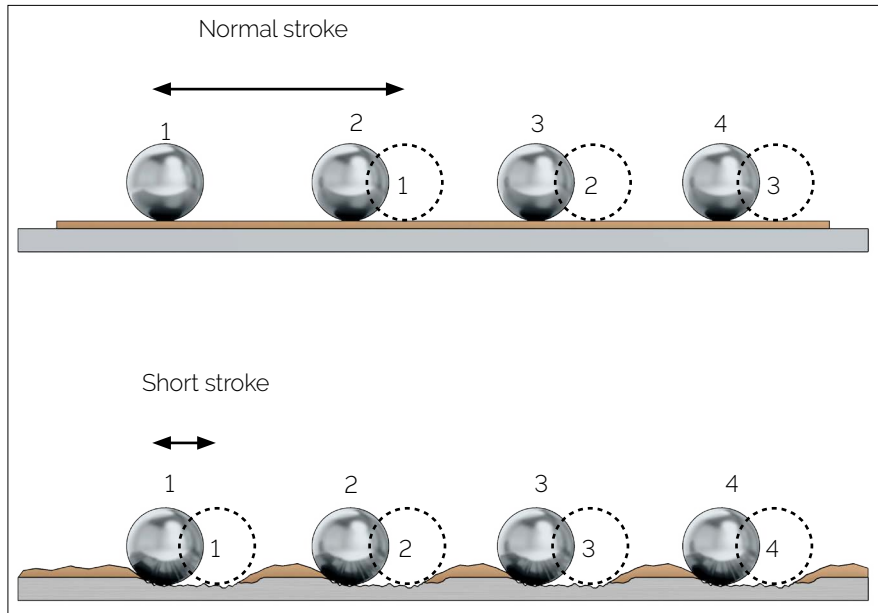

Local depressions from wear and tear form on the tracks. At highly frequent strokes the lubricating film is also interrupted

Because the tracks are concentrated at these points (depressions from wear and tear form), the precision and service life of the guideway is reduced. When the strokes are highly frequent, a standard lubricant is no longer able to reach the points of contact.

Wear and tear can be deferred with **suitable lubricants** and regular **lubrication strokes**.

Short strokes curtail the service life of the guideway considerably. The service life of the guideway(s) can only be determined by means of testing.

12 Load carrying capacity and service life

12.3 Calculating the service life L in accordance with the DIN ISO standard

The formulas for calculating service life are:

For rollers and needles:

$$L = a \cdot \left(\frac{C_{eff}}{P} \right)^{\frac{10}{3}} \cdot 10^5 \text{ m}$$

For balls:

$$L = a \cdot \left(\frac{C_{eff}}{P} \right)^3 \cdot 10^5 \text{ m}$$

a = Event probability factor
 C_{eff} = Effective load carrying capacity per rolling element in N
 P = Dynamic, equivalent load in N
 L = Nominal service life in m

Event probability factor a

The load carrying capacities for roller-contact bearings correspond to the DIN ISO standard. This represents a value from the service life calculation, which is exceeded with a probability of 90 % during operational use of the guideway.

If the previously mentioned theoretical service life probability factor of 90% is not adequate, the service life values will need to be adjusted by a factor a.

| Event probability in % | 90 | 95 | 96 | 97 | 98 | 99 |
|------------------------|----|------|------|------|------|------|
| Factor a | 1 | 0.62 | 0.53 | 0.44 | 0.33 | 0.21 |

Effective load carrying capacity C_{eff}

External influences such as track hardness and temperature can reduce the loading capacity C which means that C_{eff} needs to be calculated.

$$C_{eff} = f_H \cdot f_T \cdot C$$

C_{eff} = Effective load carrying capacity per rolling element in N
 f_H = Hardness factor
 f_T = Temperature factor
 C = Max. permissible load carrying capacity per rolling element in N

Hardness factor f_H

Materials in a frictionless guideway, which deviate from the standard conditions (HRC 58 - 62), can be recorded with the factor f_H :

| | | | | | | | | |
|---|-----|-----|-----|-----|-----|------|------|-------|
| Track hardness in HRC | 20 | 30 | 40 | 50 | 55 | 56 | 57 | 58-62 |
| Hardness factor f_H | 0.1 | 0.2 | 0.3 | 0.6 | 0.8 | 0.88 | 0.95 | 1 |

Temperature factor f_T

Increased temperatures influence the operating conditions (material properties) and must be taken into account using the factor f_T .

| | | | | |
|--|-----|-----|------|-----|
| Temperature of the guideway in °C | 150 | 200 | 250 | 300 |
| Temperature factor f_T | 1 | 0.9 | 0.75 | 0.6 |

Example calculation for C_{eff}

Guideway type R6 => Hardness 58 - 62 HRC => $f_H = 1$
 Temperature 200°C => $f_T = 0.9$
 Cage AA 6 => $C = 530$ N per roller

$$C_{eff} = f_H \cdot f_T \cdot C = 1 \cdot 0.9 \cdot 530 = \underline{477 \text{ N}}$$

12 Load carrying capacity and service life

Dynamically equivalent load P

The loads (F) acting on a linear guideway system are subject to frequent fluctuations during operation. This set of circumstances should be taken into account when calculating service life. The varying load absorption of the guideway at varying operating conditions during the travel distance is described as being the dynamic equivalent load P.

Stepped load

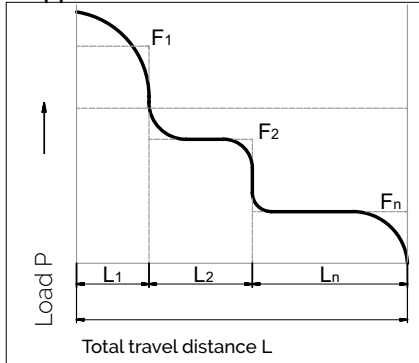

Formula for rollers and needles:

$$P = \sqrt[10]{\frac{1}{L} (F_1^{10} \cdot L_1 + F_2^{10} \cdot L_2 + \dots + F_n^{10} \cdot L_n)}$$

Formula for balls:

$$P = \sqrt[3]{\frac{1}{L} (F_1^3 \cdot L_1 + F_2^3 \cdot L_2 + \dots + F_n^3 \cdot L_n)}$$

Sinusoidal load

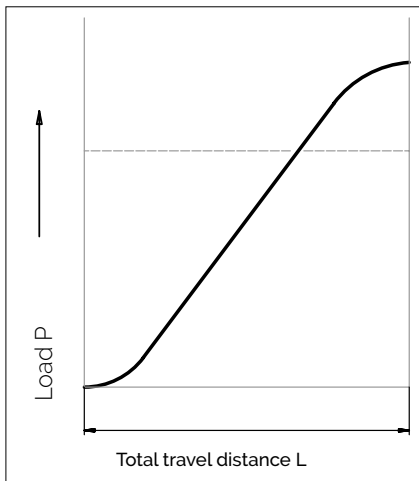

$$P = 0.7 F_{max}$$

| | |
|-----------------------------------|---|
| P | = Equivalent load in N |
| F ₁ , F _n | Individual load in N during the partial travel distance L ₁ ... L _n |
| F _{max} | Max. load in N |
| L | = L ₁ + ... + L _n = total travel during one load cycle in mm |
| L ₁ ... L _n | = partial travel distance in mm of one individual load during a load cycle |

Example calculation with a linear guideway of type RNG 6-300 with KBN 6 cage

- an event probability of 97% is selected; the corresponds to a factor a of 0.44
- the dynamic loading capacity of a roller (for KBN 6 cage) is 1'800 N. If 16 rollers are used, the loading capacity of the guideway is 16 · 1'800 N = (28'800 N)
- the application generates a total load on to the guideway of 10'000 N

With the previously mentioned values, the following calculation for service life L is:

$$L = a \cdot \left(\frac{C_{eff}}{P} \right)^{\frac{10}{3}} \cdot 10^5$$

$$L = 0.44 \cdot \left(\frac{28'800 \text{ N}}{10'000 \text{ N}} \right)^{\frac{10}{3}} \cdot 10^5 = 1'495'412 \text{ m}$$

If the service life is requested in hours, the travelled stroke H (in meters) and the time t (in seconds) required for the stroke movement must be known.

The service life L_h is calculated as follows:

$$L_h = \frac{L \cdot t}{H \cdot 3'600} = \text{Service life in hours}$$

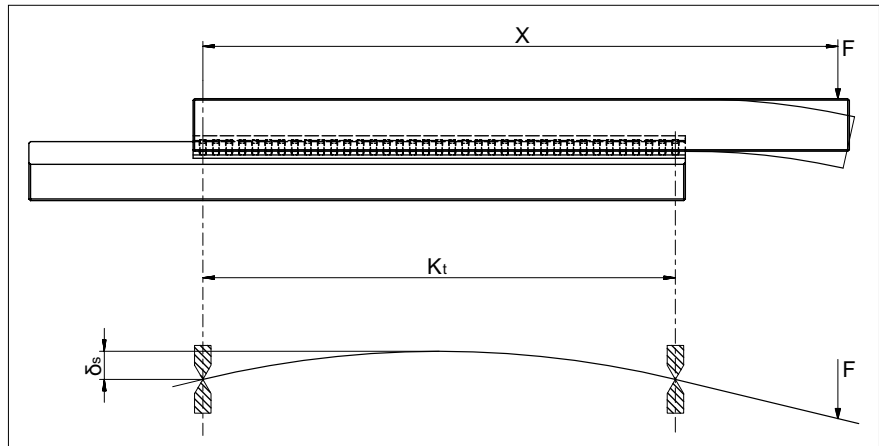
The correction factor R_{tmin} 

It was explained on the above pages how service life should be calculated from the given load carrying capacity and the occurring load. In doing so, the number of load bearing rolling elements per cage (R_t) should be taken into account.

Similarly important is estimating the behavior of the surrounding structure when transmitting forces to the frictionless guideway. Then an elastic deformation or a geometric error in a machine bed lead to the fact that only a part of the installed rolling element effectively absorbs load.

Reliable statements on this application-specific issue can usually only be made with a great deal of difficulty, for example by taking measurements on functioning models or using calculations based on the method of finite elements. The result of this is that normally dimensioning takes place by taking simplified measures, i.e. the external load is divided up on to few rolling elements using the correction factor R_{tmin} .

To determine R_{tmin} first of all the connecting structure must be assessed based on the following values from historical experience:

- A = Rigid structure
 $\delta_s \leq 0.1 \cdot \delta_A$
- B = Normal structure
 $\delta_s > \delta_A$

δ_s = deformation of the connecting structure in μm
 δ_A = deformation of the rolling element including the guide rail in μm
 (see chapter 12.5)
 F = load in N
 X = Lever arm distance on x-axis in mm
 K_t = load-bearing cage length in mm
 R_t = Number of load-bearing rollers
 R_{tmin} = Correction factor

12 Load carrying capacity and service life

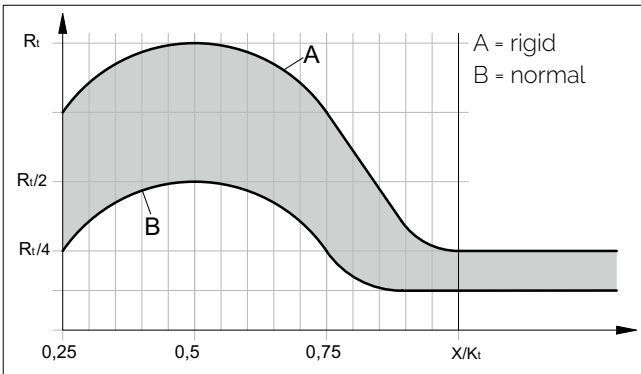

To calculate R_{tmin} according to the diagram applies

| structure | A (rigid) | B (normal) |
|-----------|-----------------------|----------------|
| $X > K_t$ | R_{tmin} to $R_t/4$ | R_{tmin} |
| $X < K_t$ | as per diagram | as per diagram |

| For R_{tmin} the following applies | Rolling element type | Cage types |
|--------------------------------------|---------------------------------|-------------------------|
| 2 | Balls | AK |
| 1 | Rollers | AA, AC, EE, KBN and KBS |
| 5 | Needles | SHW and HW |
| 0.5 | Recirculating unit with rollers | SR and NRT |
| 1 | Recirculating unit with balls | SK, SKD and SKC |

Example calculation no. 1

Linear guideway R6 with cage type AK 6/20

$X = 200$ mm

$K_t = 171$ mm

Consequently the calculation method in accordance with " $X > K_t$ " applies

The linear guideway is horizontally arranged
Thus, the following applies:

- $R_t = R_A/2 = 20/2 = 10$ rollers

Calculation for a rigid structure:

- In accordance with the table, a ball count R_{tmin} to $R_t/4$ applies
- R_{tmin} corresponds to 2 balls
- $R_t/4$ corresponds to 2.50 balls

Calculation for a normal structure:

- In accordance with the table, R_{tmin} applies
- R_{tmin} corresponds to 2 balls

Example calculation no. 2

Linear guideway R6 with cage type AK 6/11

$X = 75$ mm

$K_t = 90$ mm

Consequently the calculation method in accordance with " $X < K_t$ " applies

Calculation for a rigid structure:

According to the diagram, $X = 0.83$ of K_t (75 mm : 90 mm) and consequently $R_t/2$
With 11 load-bearing balls, this results in 5.5 balls (11 load-bearing balls : 2)

Calculation for a normal structure:

According to diagram $R_t/8$.
With 11 load-bearing balls, this results in 1.3 balls (11 : 8)

12 Load carrying capacity and service life

12.4 Example calculations

The following example calculations illustrate the procedure for some typical problems.

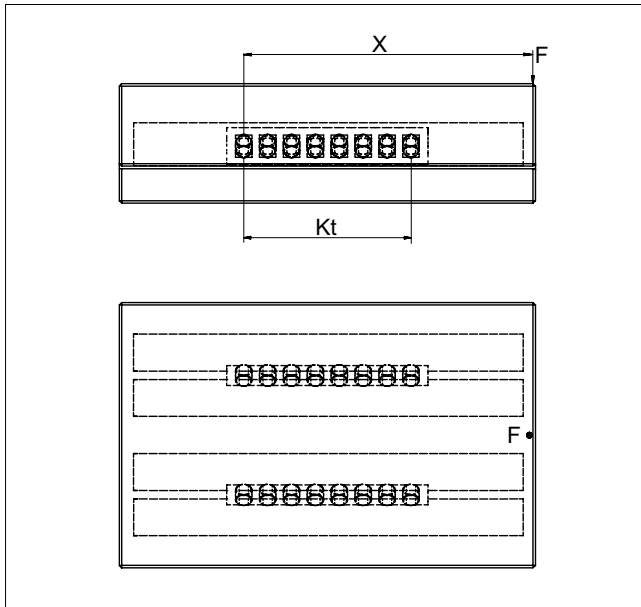

Example 1

Searched for:

Equivalent load P per roller

Assumption:

Linear guides type R 6

AC 6 cage with 8 rollers (= RA)

F = 350 N

X = 120 mm

For the roller cage type AC 6 the following applies:

$K_t = (R_A - 1) \cdot t = (8 - 1) \cdot 9 = 63$

$R_{tmin} = 1$ roller

C = 530 N

(per chapter 5.1 techn. specifications of AC 6 cage)

Note:

The asymmetric distribution of force is most safely taken into account when the load on the number of load bearing rolling elements (R_{tmin}) for the guideway is reduced.

Calculation for P per roller

$$P = \frac{F \cdot x}{K_t \cdot 2} \cdot \frac{1}{R_{tmin}}$$

$$= \frac{350 \cdot 120}{63 \cdot 2} \cdot \frac{1}{1} = 334 \text{ N}$$

P is smaller than C. The design is correct in this way.

| | |
|------------|--|
| P | = Equivalent load in N per roller |
| F | = load in N |
| C | = Max. permissible load carrying capacity per rolling element in N |
| X | = Lever arm distance on x-axis in mm |
| R_A | = Total available rolling element per cage |
| R_{tmin} | = Correction factor |
| t | = cage division in mm |
| K_t | = Load-bearing length in mm |

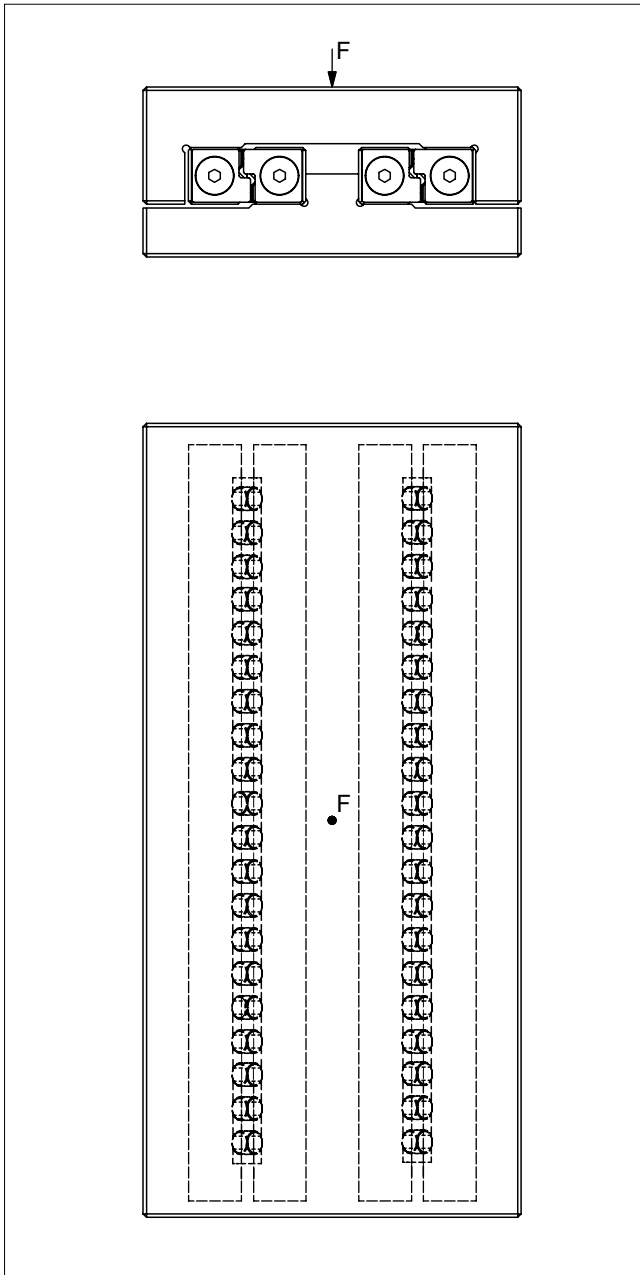

Example 2

Searched for:
Equivalent load P per roller

Assumption:
Linear guides type R 6
Roller cage type AC 6 cage with 20 rollers (= R_A)
 $F = 6500 \text{ N}$
 $C = 530 \text{ N}$ (per chapter 5.1 techn. specifications of AC 6 cage)

$$R_T = \frac{R_A}{2}$$

$$= \frac{20}{2} = 10 \text{ rollers}$$

Calculation for P per roller

$$P = \frac{F}{2} \cdot \frac{1}{R_T}$$

$$= \frac{6'500}{2} \cdot \frac{1}{10} = 325 \text{ N}$$

P is smaller than C. The design is correct in this way.

- w = Distance from cage start to the middle of the first rolling element in mm
- t = cage division in mm
- P = Equivalent load in N per roller
- F = load in N
- C = Max. permissible load carrying capacity per rolling element in N
- R_A = Total available rolling element per cage
- R_t = Number of load-bearing rolling elements per cage

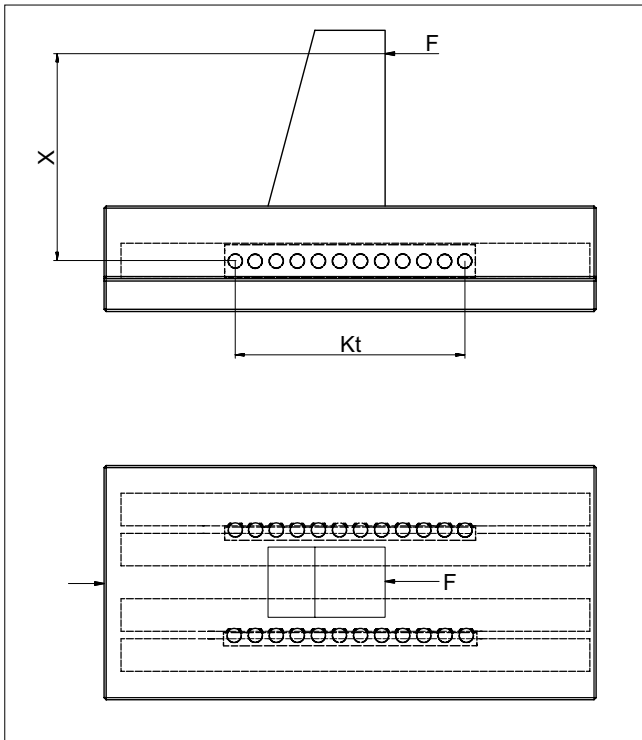

Example 3

Searched for:

Equivalent load P per ball

Assumption:

Rigid slide structure

Linear guides type R 6

Cage type AK 6 with 12 balls (= RA); t = 9 mm

(according to chapter 5.1, technical data for the AK 6 cage)

$$R_A = R_T = 12 \text{ balls}$$

$$R_{tmin} = 3 = R_t/4 \text{ according to diagram on page 101}$$

$$K_t = (R_A - 1) \cdot t$$

$$F = 240 \text{ N}$$

$$X = 75 \text{ mm (distance F to opposing force)}$$

$$C = 65 \text{ N (according to chapter 5.1, technical data for the AK 6 cage)}$$

Calculation for P per ball:

$$P = \frac{F}{K_t} \cdot \frac{X}{2} \cdot \frac{1}{R_{tmin}}$$

$$= \frac{240}{99} \cdot \frac{75}{2} \cdot \frac{1}{3} = 30 \text{ N}$$

P is smaller than C. The design is correct in this way.

| | |
|-------------------|--|
| t | = cage division in mm |
| P | = Equivalent load in N per ball |
| F | = load in N |
| C | = Max. permissible load-carrying capacity per rolling element in N |
| R _{tmin} | = Correction factor |
| R _A | = Total available rolling elements per cage |
| R _t | = Number of load-bearing rolling elements per cage |
| K _t | = Load-bearing length in mm |

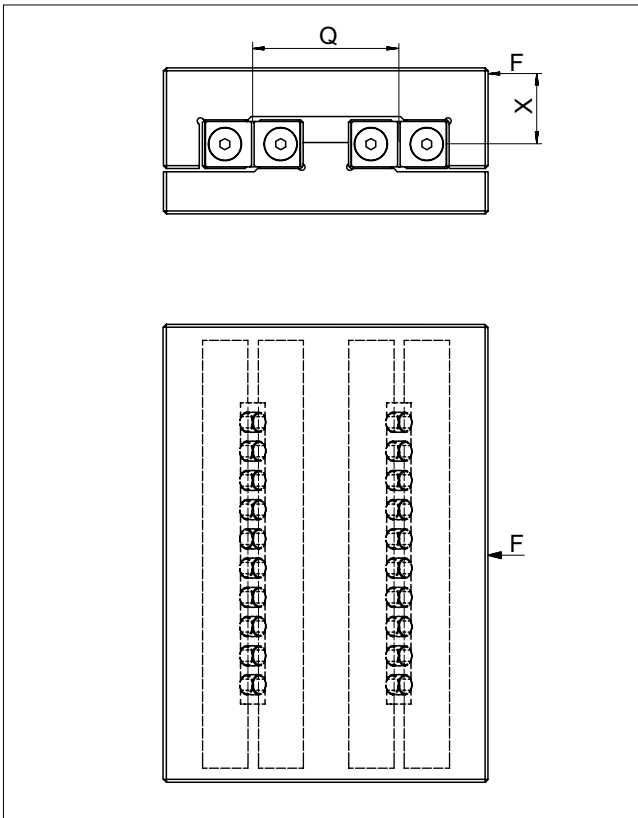

Example 4

Searched for:

Equivalent load P per roller and the suitable size RNG guideways

Assumption:

Type RNG linear guideways
Roller cage type KBN with 10 rollers (R_A)

$F = 15'000 \text{ N}$

$X = 50 \text{ mm}$

$Q = 100 \text{ mm}$

$$R_T = \frac{R_A}{2}$$

$$= \frac{10}{2} = 5 \text{ rollers}$$

Calculation for P per roller

$$P_1 = \frac{F \cdot X}{Q} \cdot \frac{1}{R_T}$$

$$= \frac{15'000 \cdot 50}{100} \cdot \frac{1}{5} = 1'500 \text{ N}$$

$$P_2 = \frac{F}{R_A}$$

$$= \frac{15'000}{10} = 1'500 \text{ N}$$

$$P = P_1 + P_2$$

$$= 1'500 + 1'500 = 3'000 \text{ N}$$

| | |
|------------|--|
| P (P1, P2) | = Equivalent loads in N per roller |
| F | = load in N |
| X | = Lever arm distance on x-axis in mm |
| Q | = Medium linear guideway distance in mm |
| C | = Max. permissible load carrying capacity per rolling element in N |
| R_A | = Total available rolling element per cage |
| R_t | = Number of load-bearing rolling elements per cage |

Definition of the suitable guideway size:

According to product specification for the KBN cage (chapter 5.2 or 5.3) if $C = 3'900 \text{ N}$ were to be selected

| Type | Size | Dw | t | w | C per roller in N |
|------|------|-----|-----|-------------|-------------------|
| KBN | 4 | 4.5 | 6.5 | approx. 4 | 850 |
| | 6 | 6.5 | 8.5 | approx. 5 | 1800 |
| | 9 | 9 | 12 | approx. 7.5 | 3900 |
| | 12 | 12 | 15 | approx. 9 | 6500 |

The roller size 9 is suitable. Thus select cage KBN 9 and the linear guideway RNG 9, provided the service life has been fulfilled.

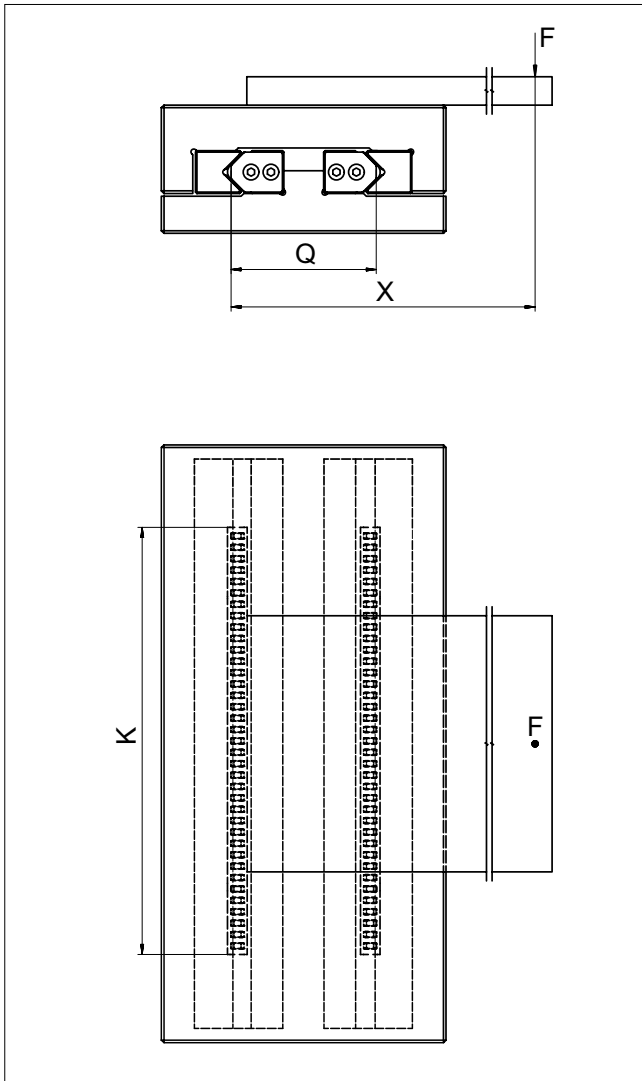
**Example 5**

Searched for:

Equivalent load P per needle

Assumption:

Linear guideways type N/O 2025

SHW 15 cage, cage length K = 194 mm

(w = 2.9 mm according to techn. specifications of the SHW 15 cage)

F = 5'000 N

X = 280 mm

Q = 75 mm

C = 750 N (according to techn. specifications for the AC 15 cage)

$$R_A = \left(\frac{K - 2w}{t} + 1 \right) \cdot 2$$

$$= \left(\frac{194 - 5.8}{4} + 1 \right) \cdot 2 = 96 \text{ needles}$$

$$R_t = \frac{R_A}{2} = 48 \text{ needles}$$

Calculation for P per needle:

$$P = \frac{F \cdot X}{Q} \cdot \frac{1}{R_t}$$

$$= \frac{5'000 \cdot 280}{75} \cdot \frac{1}{48} = 389 \text{ N}$$

P is smaller than C. The design is correct in this way.

w = Distance from cage start to the middle of the first rolling element in mm
t = element in mm
P = cage division in mm
F = Equivalent load in N per needle
X = load in N
Q = Lever arm distance on x-axis in mm
C = Medium linear guideway distance in mm
= Max. permissible load carrying capacity per rolling element in N
R_t = element in N
R_A = Number of load-bearing rolling elements per cage
K = Total available rolling element per cage
= Cage length in mm

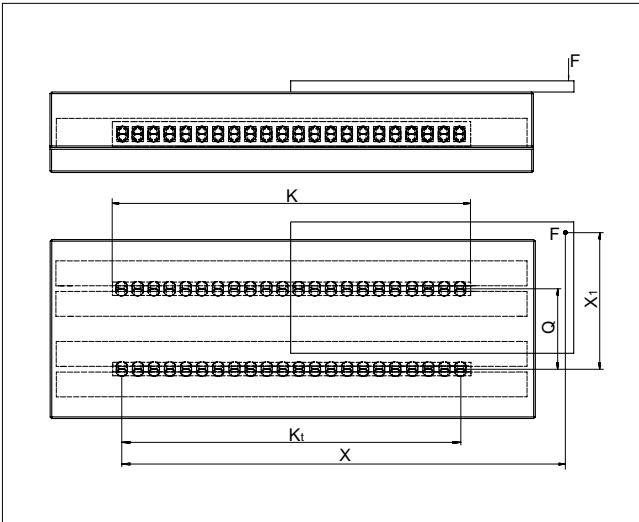

Example 6

Searched for:
Equivalent load P per roller

Assumption:

- Rigid structure
- Linear guides type R 12
- Cage type AC 12, length K = 400 mm
- F = 2'000 N
- X = 500 mm
- X₁ = 200 mm
- Q = 100 mm
- C = 2'500 N (see chapter 5.1, technical specifications for the AC 12 cage)

For the roller cage AC 12 the following applies:

$$K_t = K - 2w = 400 - 22 = 378 \text{ mm}$$

$$R_A = \frac{K_t}{t} + 1 = \frac{378}{18} + 1 = 22 \text{ rollers}$$

$$R_t = \frac{R_A}{2} = \frac{22}{2} = 11 \text{ rollers}$$

$X > K_t = R_t/4$ (according to the diagram on page 101)

$$R_{TQ} = R_t$$

$$R_{TL} = \frac{R_t}{4} = \frac{11}{4} = 2.75 \text{ rollers (rounded down to 2)}$$

| | |
|----------------|---|
| w | = Distance from cage start to the middle of the first rolling element in mm |
| t | = element in mm |
| P | = cage division in mm |
| F | = Equivalent load in N per roller |
| X | = load in N |
| X ₁ | = Lever arm distance on x-axis in mm |
| Q | = Lever arm distance 1 on x-axis in mm |
| C | = Medium linear guideway distance in mm |
| | = Max. permissible load carrying capacity per rolling element in N |
| R _t | = Number of load-bearing rolling elements per cage |
| R _A | = Total available rolling element per cage |
| K | = Cage length in mm |
| K _t | = Load-bearing length in mm |
| ...L | = Longitudinally |
| ...Q | = Laterally |

Calculation for P per roller

Load laterally

$$P_Q = \frac{F \cdot X_1}{Q} \cdot \frac{1}{R_{TQ}} = \frac{2'000 \cdot 200}{100} \cdot \frac{1}{11} = 364 \text{ N}$$

Load longitudinally

$$P_L = \frac{F \cdot X}{K_t \cdot 2} \cdot \frac{1}{R_{TL}} = \frac{2'000 \cdot 500}{378 \cdot 2} \cdot \frac{1}{2} = 662 \text{ N}$$

$$P = P_Q + P_L = 364 + 662 = 1'026 \text{ N}$$

P is smaller than C. The design is correct in this way.

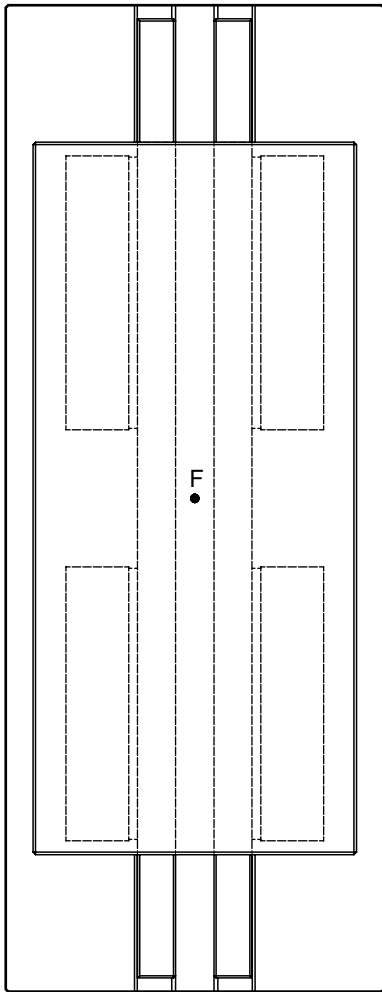
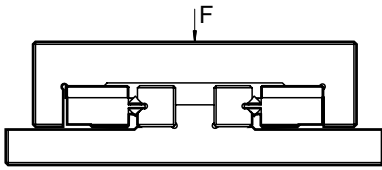
**Example 7**

Searched for:

Equivalent load P

Assumption:

Recirculating unit type SR 6-100

Linear guides type R 6

 $R_t = 2$ recirculating unit $F = 6'000$ N $C = 2'150$ N (see chapter 6.3. technical specifications for the recirculating unit)

Calculation for P:

$$P = \frac{F}{2} \cdot \frac{1}{R_t}$$

$$= \frac{6'000}{2} \cdot \frac{1}{2} = 1'500 \text{ N}$$

P is smaller than C. The design is correct in this way.

P = Equivalent loads in N

F = load in N

C = Max. permissible load carrying capacity in N

 R_t = Number of load-bearing recirculating units

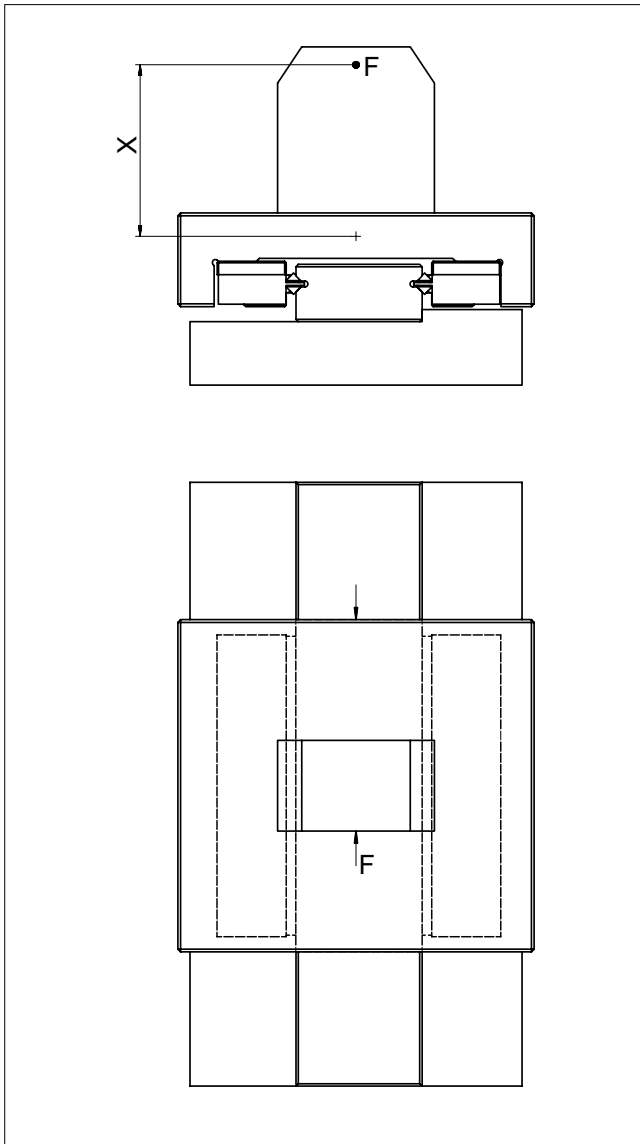

Example 8

Searched for:

Moment load M in Nm longitudinally and laterally

Assumption:

Recirculating unit type SR 6-150

Linear guideways type RD 6

$M_L = 112$ Nm (according to chapter 6.3, technical specifications

for the recirculating unit)

$X = 45$ mm (distance F to opposing force)

$F = 2'000$ N

Calculation for M:

$$M = F \cdot X = 2000 \cdot 0,045 = 90 \text{ Nm}$$

The moment load M is below the permissible load M_L . Thus the design is correct.

M = Moment load in Nm longitudinally and laterally

M_L = Permitted moment load in Nm longitudinally and laterally

X = distance in mm

F = load in N

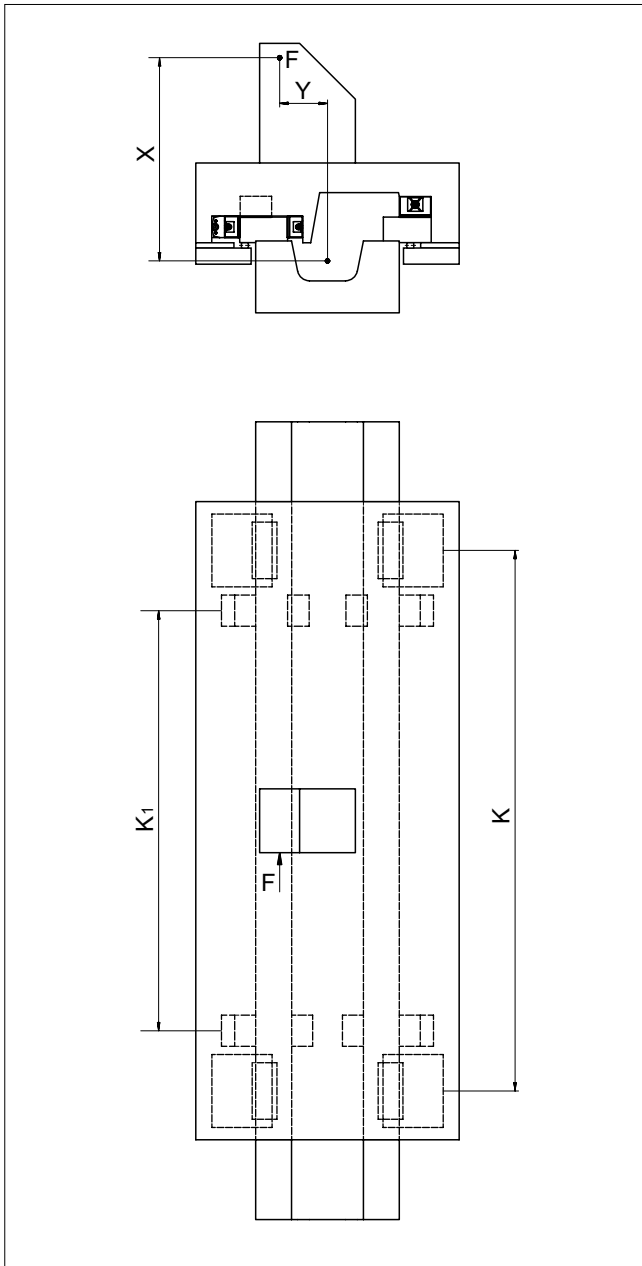

Example 9

Searched for:

Equivalent loads P_L and P_Q

Assumption:

Recirculating unit top type NRT 26 111 (C = 98'000 N)

Recirculating unit bottom type NRT 19 077 (C = 43'000 N)

Recirculating unit side type NRT 19 077 (C = 43'000 N)

K = 700 mm

K_1 = 450 mm

R_{tmin} = 0.5 (according to table on page 101)

F = 83'000 N

X = 500 mm

Y = 100 mm

Calculation for P_L and P_Q :

Load longitudinally

$$P_L = \frac{F \cdot X}{K \cdot 2} \cdot \frac{1}{R_{tmin}}$$

$$= \frac{83'000 \cdot 500}{700 \cdot 2} \cdot \frac{1}{0.5} = 59'286 \text{ N}$$

Load laterally

$$P_Q = \frac{F \cdot Y}{K_1 \cdot 2} \cdot \frac{1}{R_{tmin}}$$

$$= \frac{83'000 \cdot 100}{450} \cdot \frac{1}{0.5} = 36'889 \text{ N}$$

- P = Equivalent load in N
- P_L = Equivalent load longitudinally in N
- P_Q = Equivalent load laterally in N
- F = load in N
- X = distance in mm
- Y = distance in mm
- C = Max. permissible load carrying capacity per recirculating unit in N
- R_{tmin} = Correction factor
- K = Spacing between the recirculating units in mm
- K_1 = Spacing between the recirculating units in mm

12 Load carrying capacity and service life

12.5 Elastic deformation and rigidity of linear bearings

Linear guideways

The total deformation δ_A (that is the deformation of the rolling element in connection with hardened tracks (min. 58 HRC)) can be deduced from the following diagrams.

The elastic deformation of the linear guideways of type R with rollers

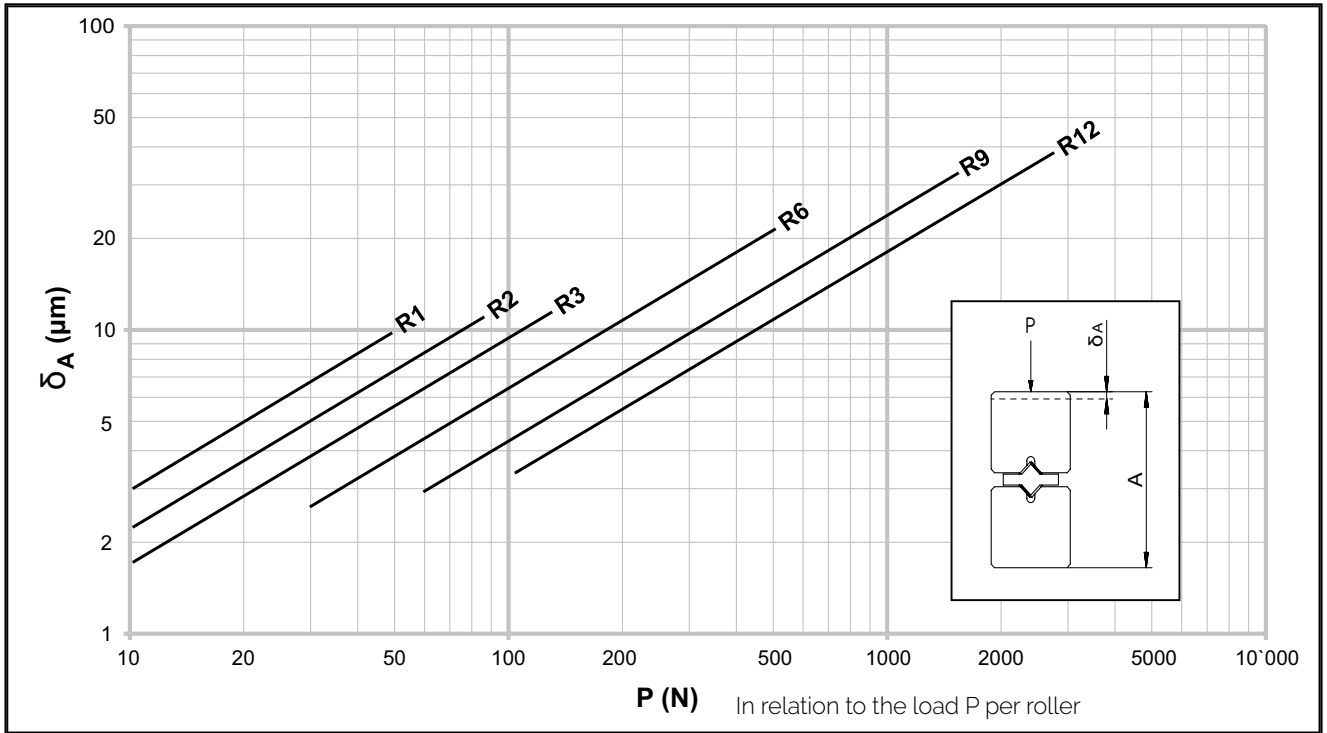

The elastic deformation of the linear guideways of type R with balls

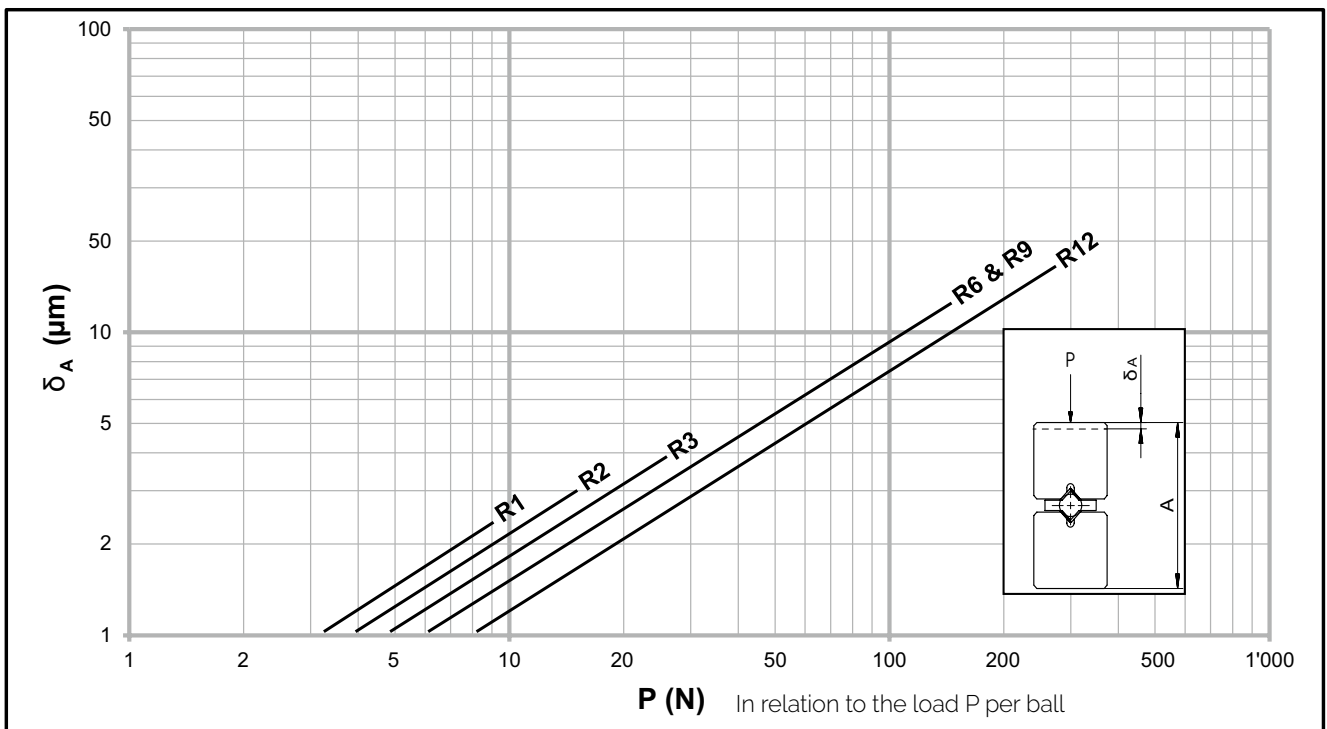

12 Load carrying capacity and service life

The elastic deformation of the linear guideways for type RN and RNG.

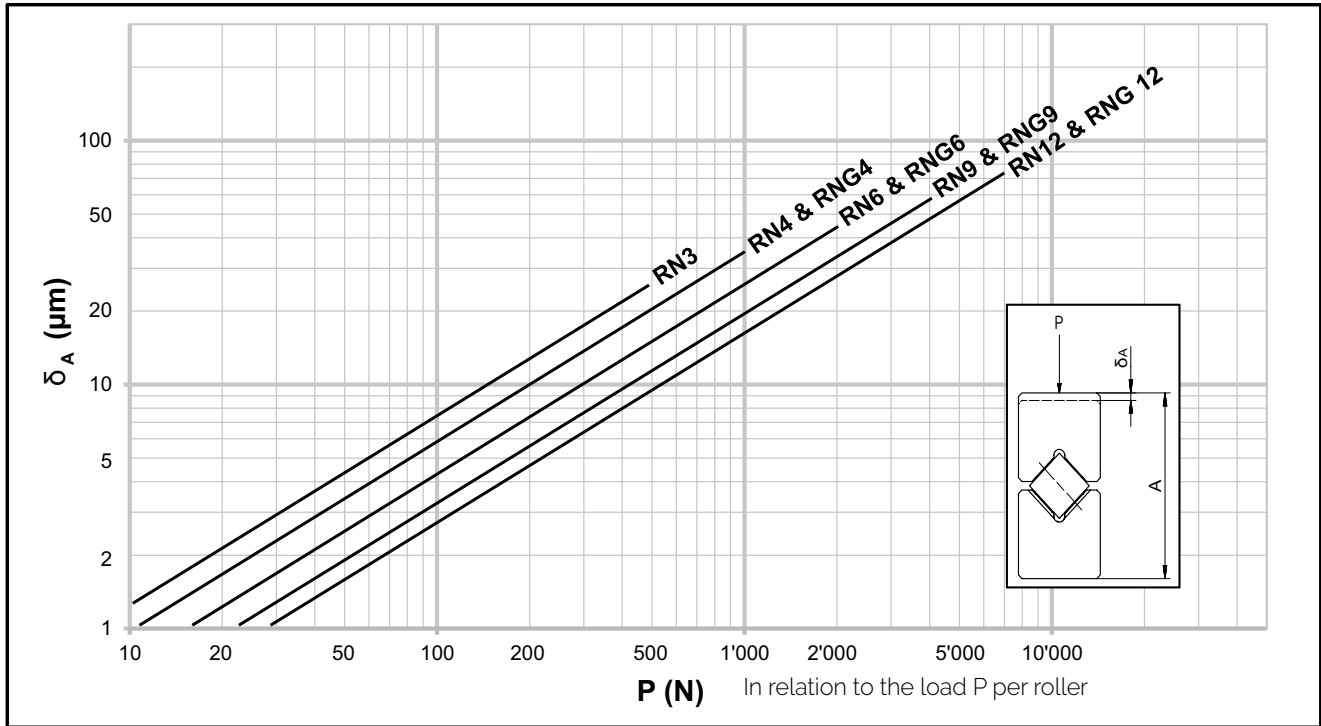

The elastic deformation of the linear guideways of types N/O and M/V upon use with the following types of cages

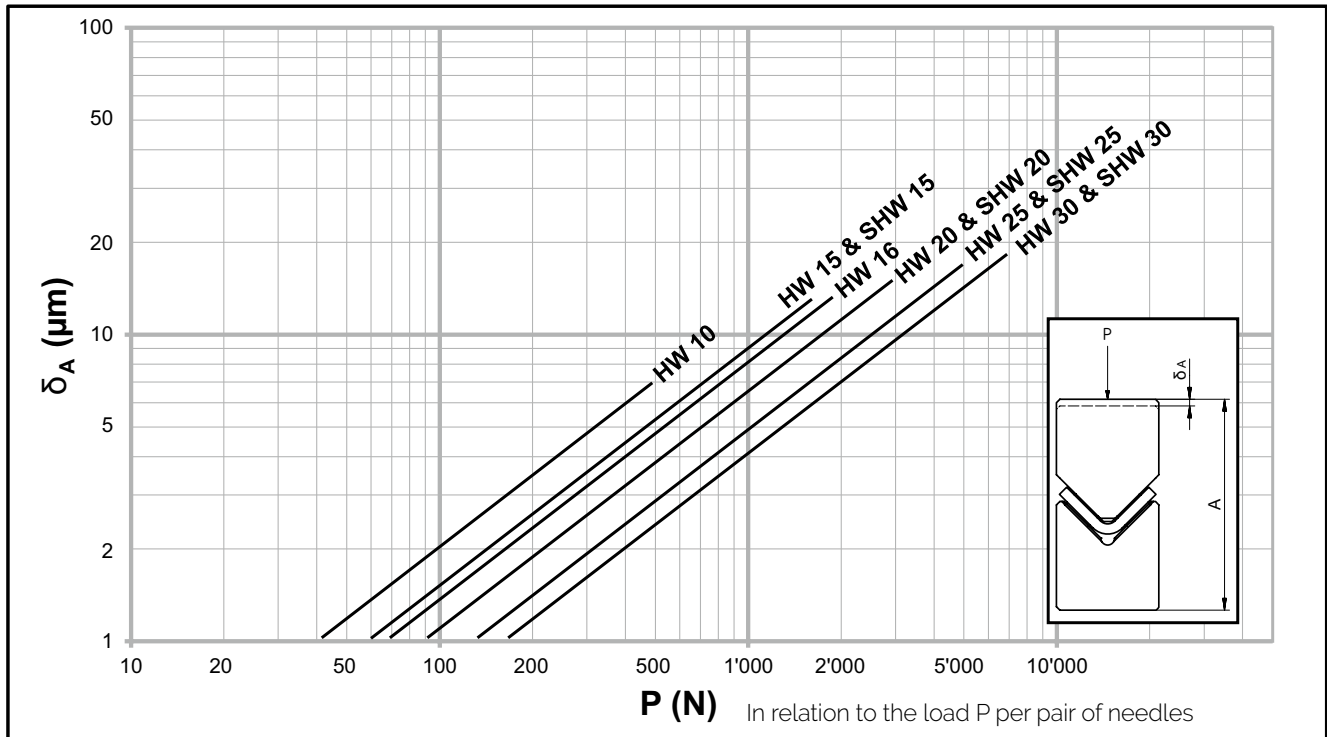

12 Load carrying capacity and service life

12.6 Elastic deformation and rigidity of recirculating units

The elastic deformation of the recirculating unit of type SK in connection with linear guideways type R or RD.

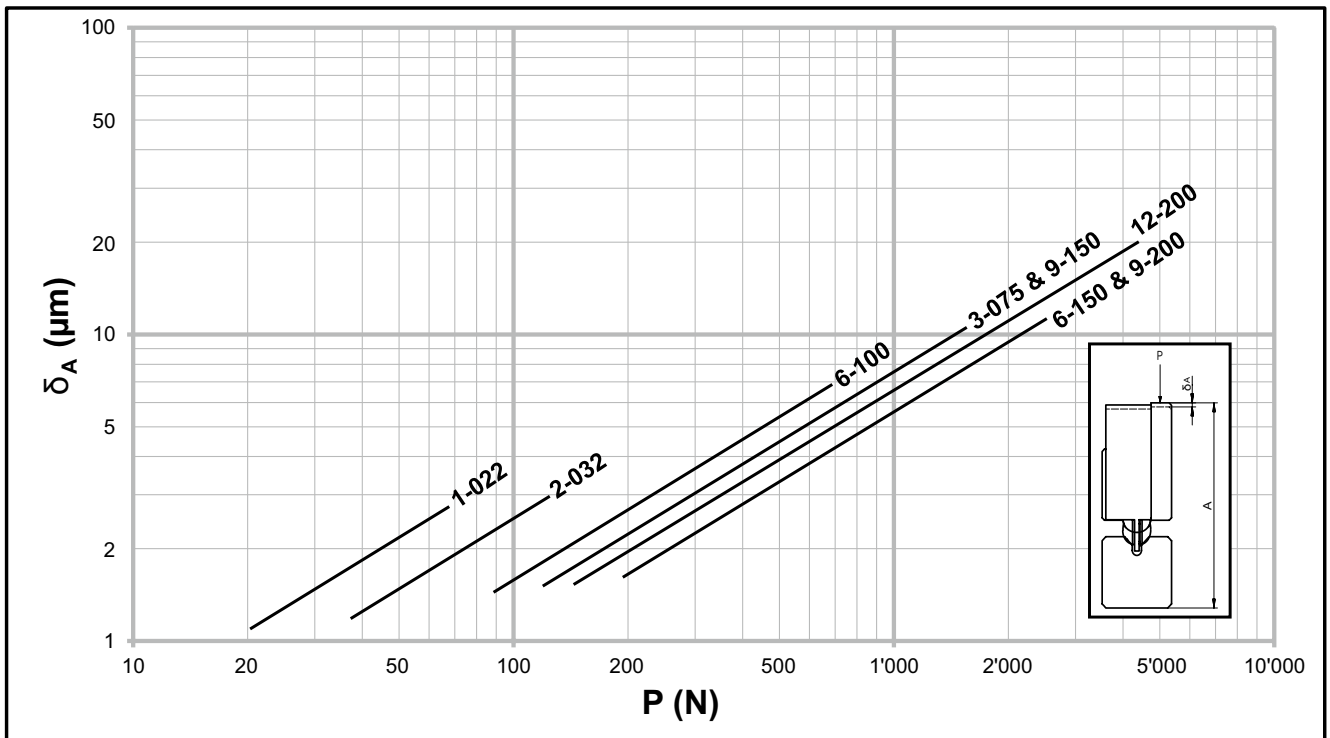

The elastic deformation of the recirculating unit of type SKD in connection with linear guideways type R or RD.

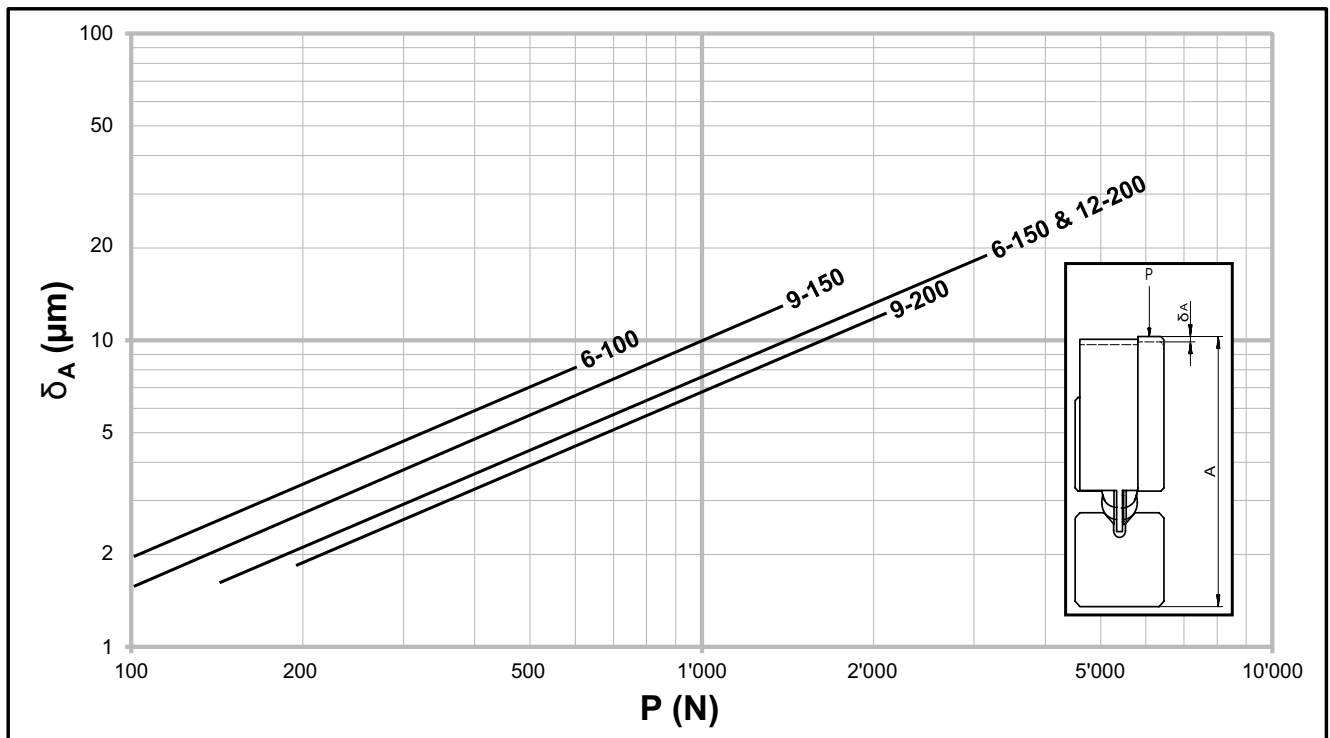

12 Load carrying capacity and service life

The elastic deformation of the recirculating unit of type SKC in connection with linear guideways type R or RD. The total length of the straight lines applies for lubricated recirculating units, the dotted straight line for unlubricated ones.

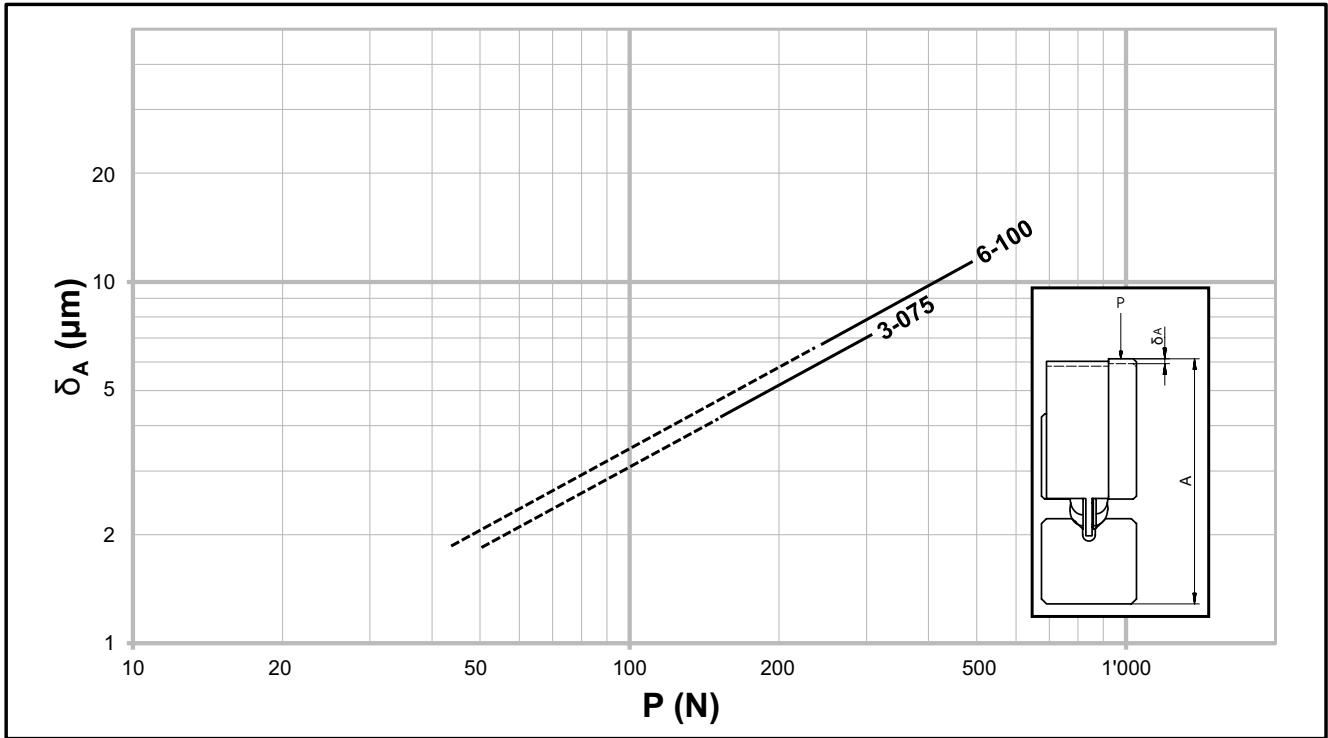

The elastic deformation of the recirculating unit of type SR in connection with linear guideways type R or RD.

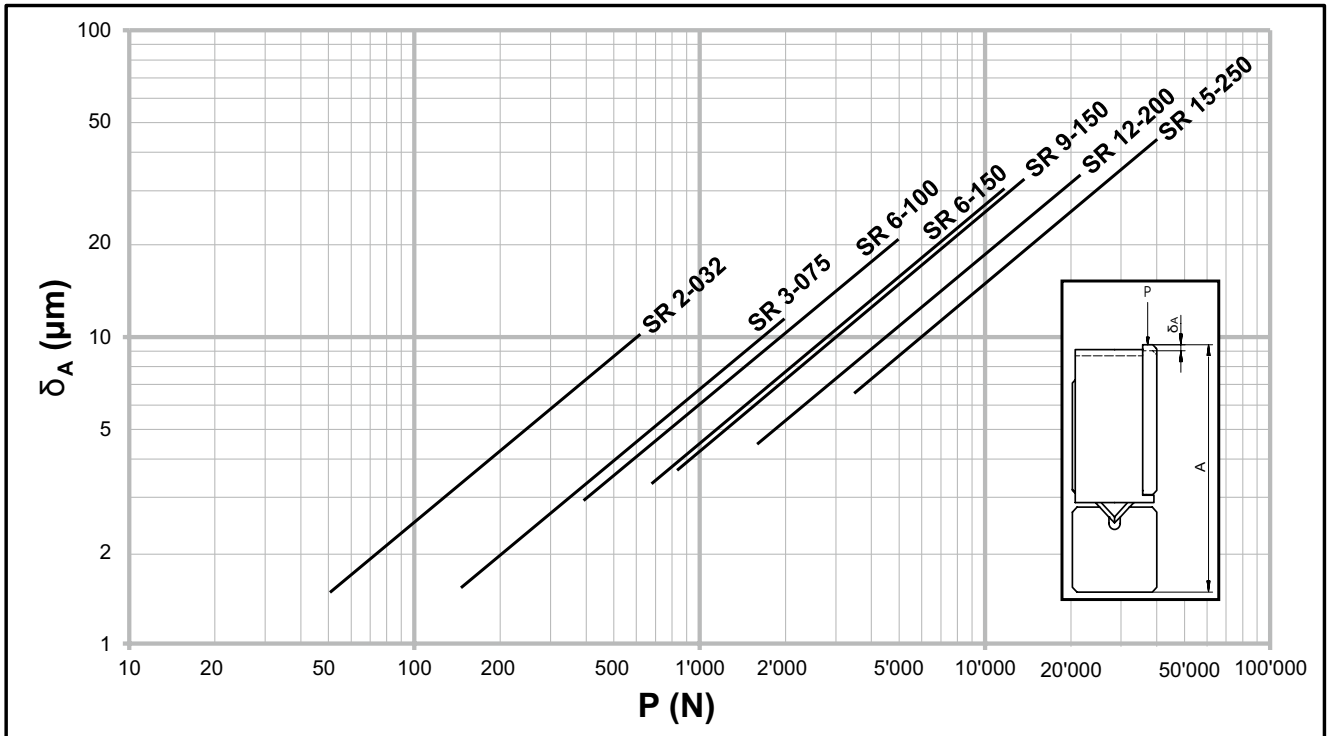

The elastic deformation of the recirculating unit type NRT.

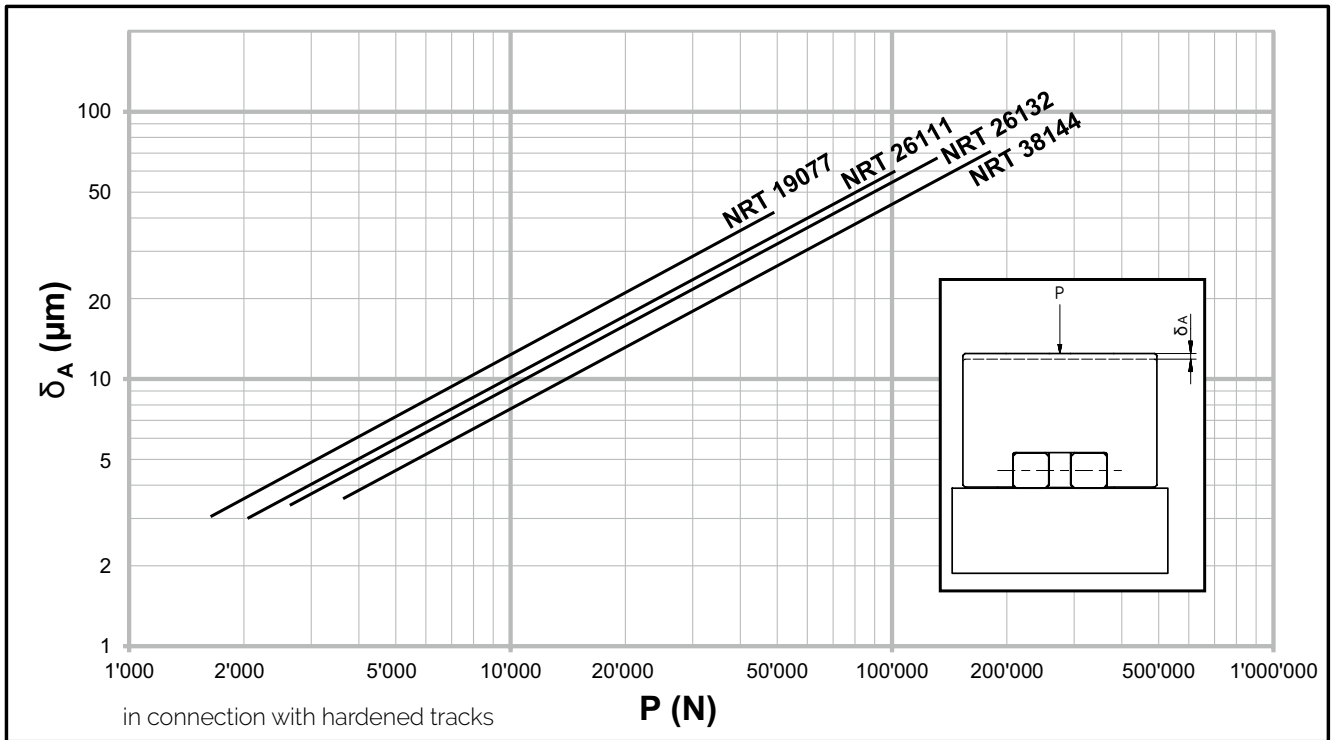

13 Construction and installation guidelines

13.1 The connecting structure and its influence on service life

Linear guideways are high-precision components. The requirements for the connecting structure are also high to ensure the accuracy of the guideways are maximized.

The quality of the reference and supporting surfaces as well as the rigidity of the connecting structure must meet the most stringent requirements. If this is not the case, smoothness, precision and service life of the guideway will be significantly affected.

To exploit the full potential of the linear guideways, assembly on a rigid and ground substrate is recommended. Connecting structures made of light metal are only suitable in certain instances - due to their lower rigidity and limited machining accuracy.

13.2 Configuration of the connecting structure

Parallelism of the reference and locating surfaces

They must be compatible with those of the linear guideway (also applies when using linear guideways with recirculating units):

| | |
|-----|-----------------------|
| NQ | Normal quality |
| SQ | Special quality |
| SSQ | Super special quality |

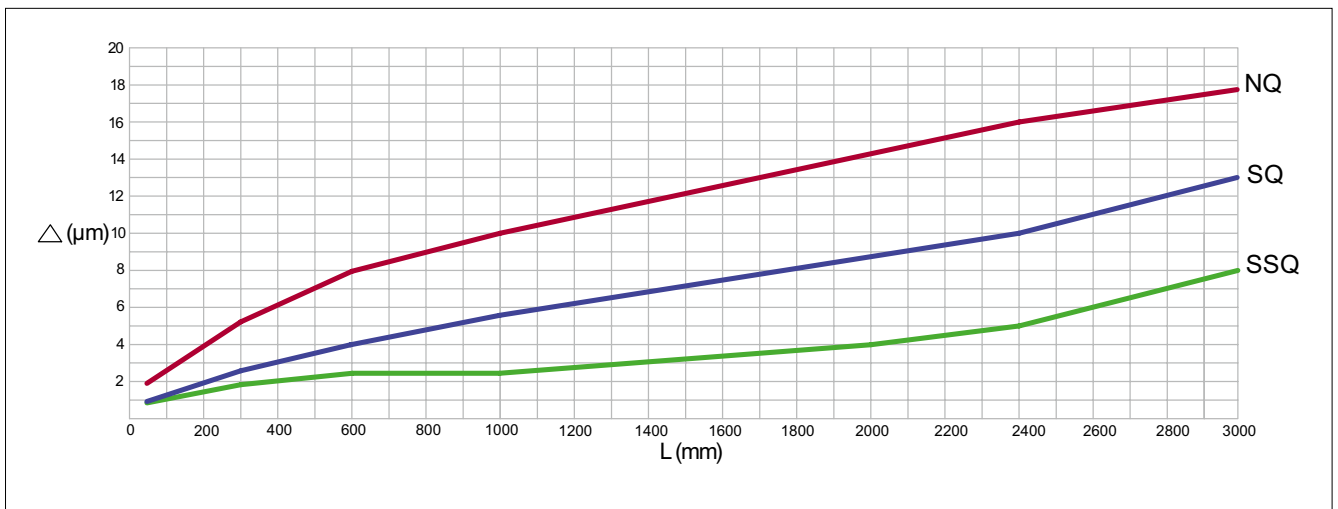

Surface quality

The accuracy of the application critically determines the required surface quality of the reference and locating surfaces. For high-precision applications they must demonstrate a maximum Ra value of 0.4. An Ra value of 1.6 may not be exceeded for standard applications.

Angular error

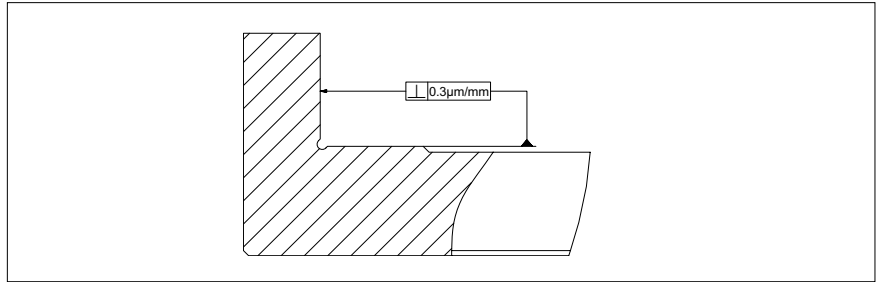

The angular errors for the supporting and locating surface should not exceed 0.3 $\mu\text{m}/\text{mm}$.

Height offset for linear guideways

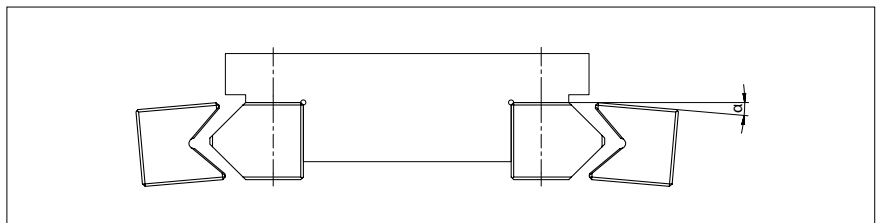

The angular errors resulting from height offset and/or elastic deformations may not exceed the following values:

- Balls or rollers: 0.3 $\mu\text{m}/\text{mm}$
- Needles 0.1 $\mu\text{m}/\text{mm}$

Parallelism of the supporting and locating surfaces in the case of the recirculating unit

The parallelism of the supporting and locating surfaces in relation to the mating track can be derived from the diagram below:

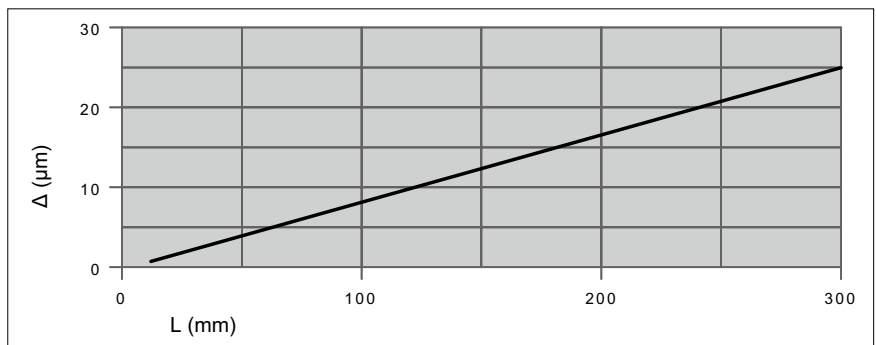

Height offset for recirculating units

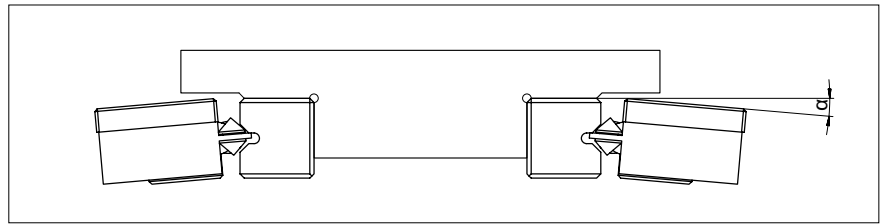

The angular errors results from height offset and/or elastic deformations may not exceed the following values:

| | |
|---------------------------|-----------------------------|
| For types SK, SKD and SKC | 3.0 $\mu\text{m}/\text{mm}$ |
| For types SR | 0.3 $\mu\text{m}/\text{mm}$ |

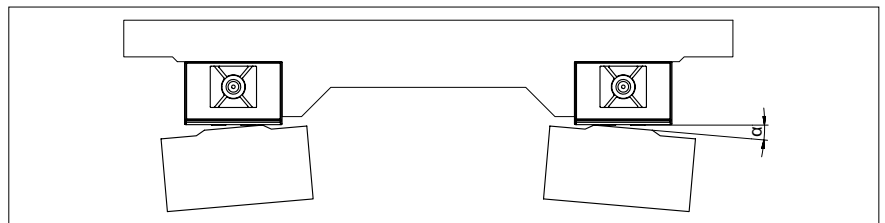

For types NRT 0.3 $\mu\text{m}/\text{mm}$

Combination of recirculating unit NRT with preload wedge NRV

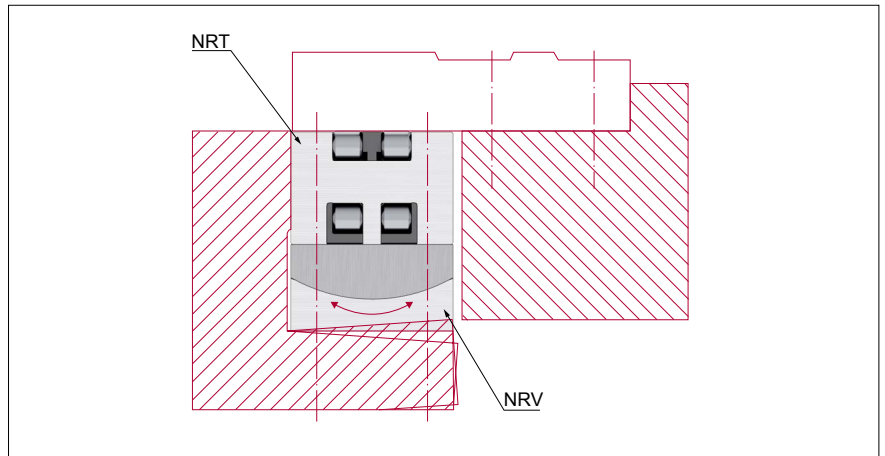

So that straight run-off is guaranteed, the recirculating unit NRT must always be oriented against the locating surface. The preload wedge NRV should be aligned opposite the recirculating unit and compensates for angular errors.

13 Construction and installation guidelines

13.3 Installation methods

SCHNEEBERGER linear guideways are not designed to be load-bearing structural components, but as guideway components.

Horizontal installation indicates direction of movement runs horizontally. Likewise, vertical installation indicates direction of movement deviates from the horizontal plane.

Enclosed configuration

The enclosed configuration is a fixed/fixed bearing. It can be loaded by moments and forces in any direction. Rigidity and running accuracy can be influenced by a change in the preload.

The advantages and characteristics of an enclosed configuration:

- Supports any operation position, load direction and moment load
- Supports a small guideway base
- Must be preloaded. Consequently, rigidity and accuracy are increased.

An example involving linear guideways of type R, RN or RNG

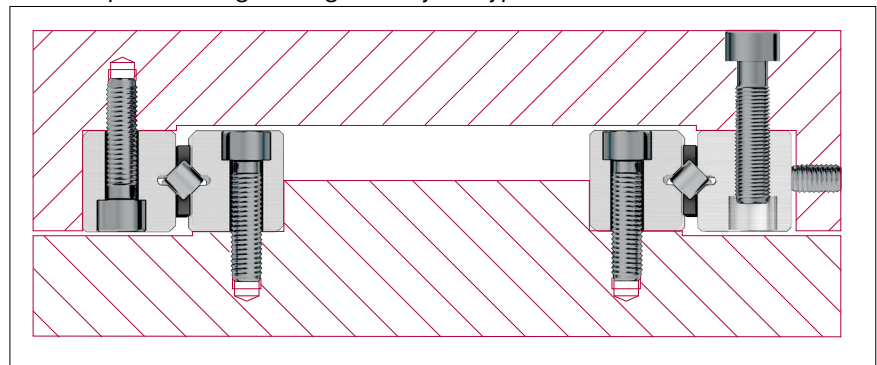

An example involving linear guideways of type N/O or M/V

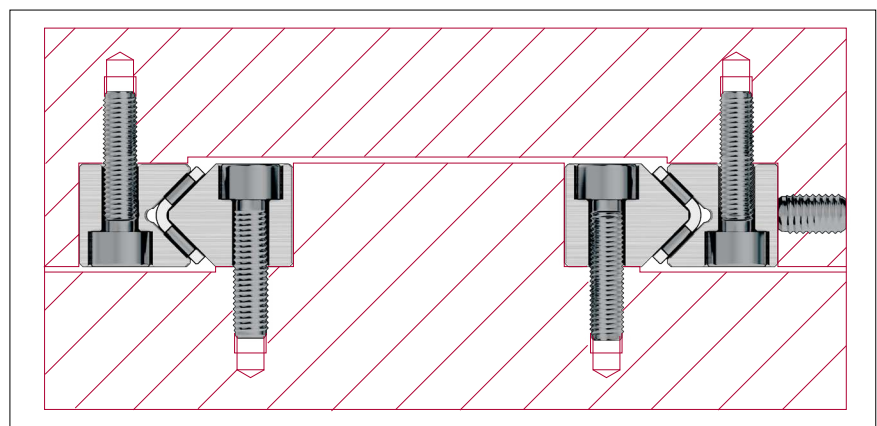

Example with recirculating units of type SK, SKD, SKC or SR combined with the double V-shaped guide RD

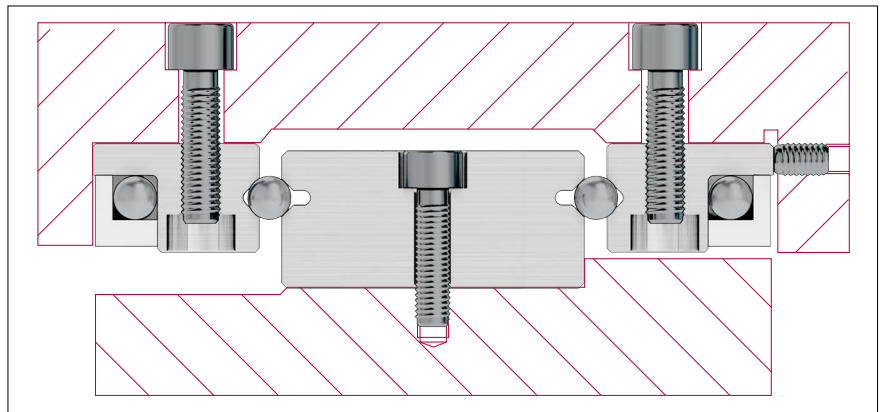

Example involving recirculating unit of type SK and linear guideways of type R

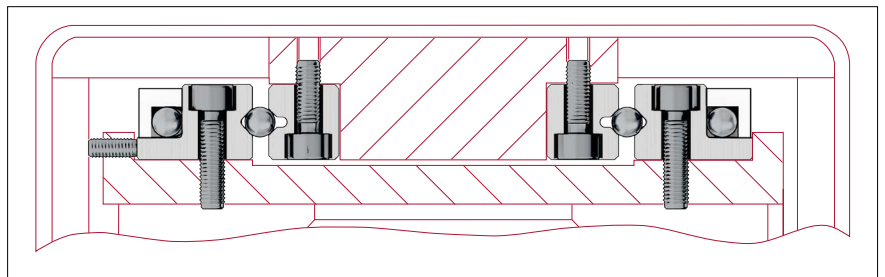

Example involving recirculating unit of type NRT and surface guideways of type E

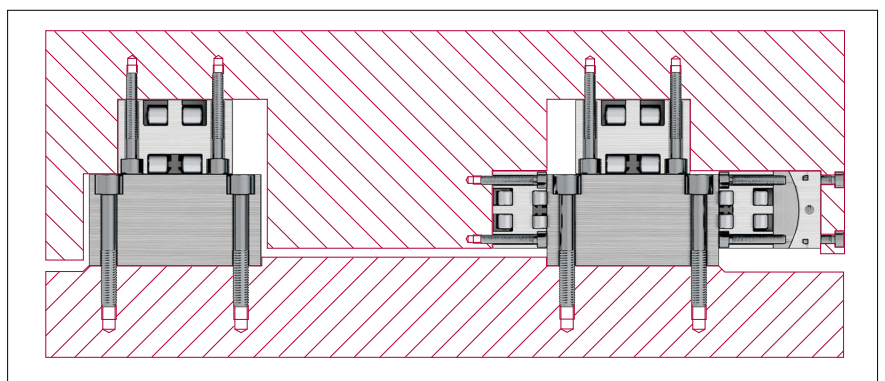

Open configuration

The open configuration is a fixed/loose bearing offering the following advantages and characteristics:

- Is mainly used when the load acts centrally and vertically on to the guideway plane and no deformations may occur by tensioning the surrounding structure.
- Thermal lateral variations are evened out
- Large bearing spans can easily be bridged
- Requires a large guideway base
- Very installation-friendly as the machine component can easily be seated and/or lifted off

Example involving linear guideways of type R, RN or RNG combined with a surface guideway of type W/Z. In the case of open configurations, the height A for both pairs of guideways must be height-matched (see chapter 7.5).

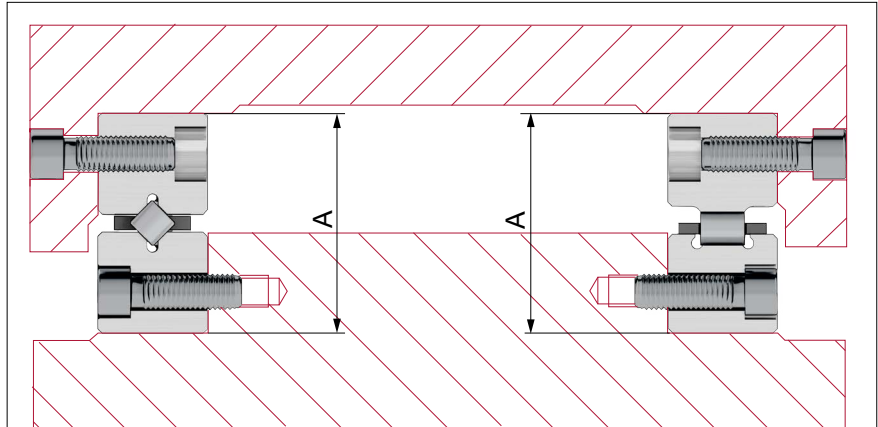

Example of a suspended linear guideway of type N/O or M/V combined with a surface guideway of type L/M. The dimensions A and B must be height-matched.

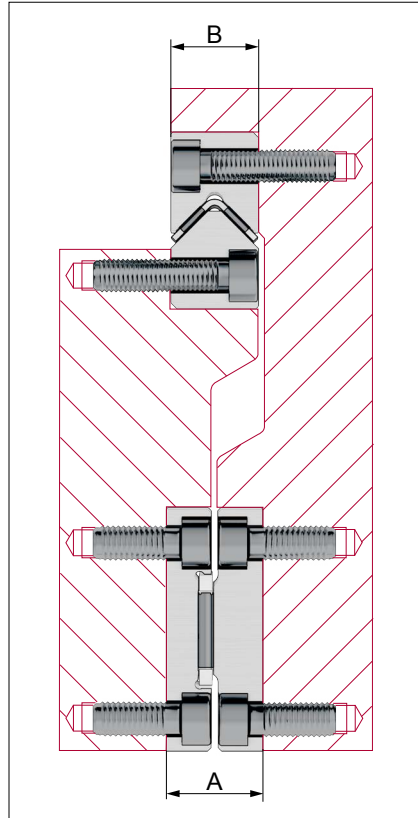

Example involving recirculating unit of type NRT and surface guideways of type E. The vertical load is born by height-matched NRT

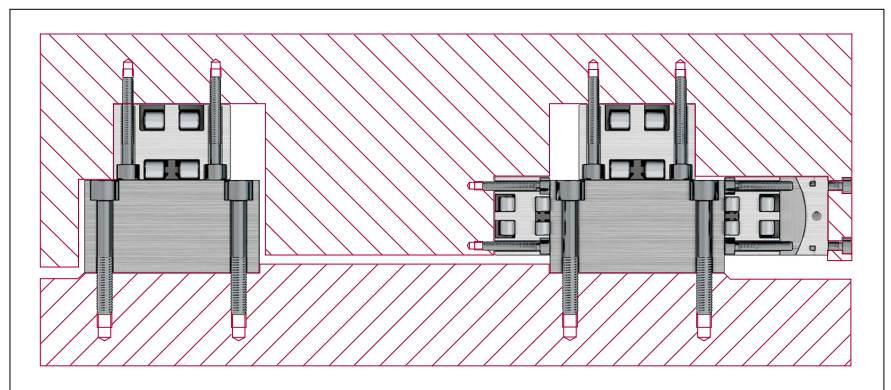

13 Construction and installation guidelines

13.4 Fastening

Linear guideways

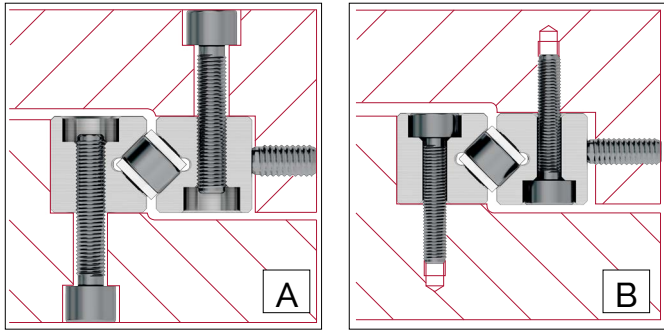

Fastening variants

The SCHNEEBERGER linear guideways and recirculating units can be fastened to the connecting structure in two different ways:

- A The use of the tapped boreholes
- B The use of through holes

Method A is preferred because a powerful fastening is possible based on the screw size

Method B provides added flexibility combined with the fastening screws with a thin shaft (see chapter 5).

Recirculating units

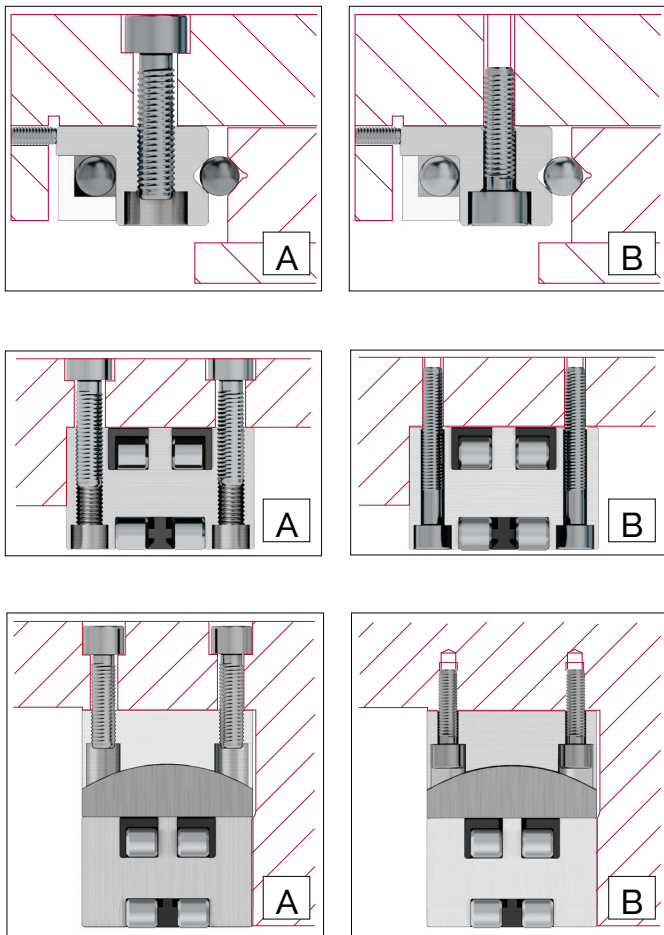

13 Construction and installation guidelines

13.5 Torque settings for fastening screws

The recommended torque settings can be found in the table. These values apply in respect of oiled screws.

By using greases containing MoS², the required torque can drop to half of the values set out below.

Strength grade 8.8

| Sizes | Max. tightening torque in Ncm* | |
|-------|--------------------------------|--|
| | Fastening screws DIN 912 | Fastening screws with thin shaft, type GD or GDN |
| M 2 | 35 | - |
| M 2.5 | 73 | 54 |
| M 3 | 128 | 94 |
| M 4 | 290 | 221 |
| M 5 | 575 | 463 |
| M 6 | 990 | 762 |
| M 8 | 2400 | 1838 |
| M 10 | 4800 | 3840 |
| M 12 | 8300 | 6579 |
| M 14 | 13200 | 10631 |
| M 16 | 20000 | - |

* Tightening torques apply for materials with a tensile strength of > 360N/mm²

13 Construction and installation guidelines

13.6 Preload

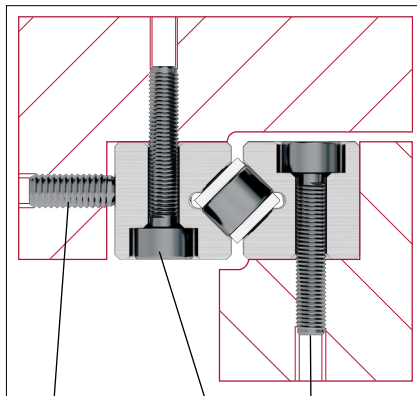

Adjusting screws

Fastening screws

The size of the preload is guided by the intended use of the guideways. A high preload ...

- ... increases rigidity of the guideway and guarantees zero-backlash
- ... reduces moment loads, maximum loads on the rolling element
- ... increases displacement resistance
- ... reduces the service life

A positive effect of preload is achieved with 5 % - 20 % of the permissible load C.

General approach

The preload can be consistently set using a torque wrench. In so doing the friction between screw and tapped fixing hole must be taken into account (to be determined by means of tests).

When using **wedge adjusters** or **adjusting plates**, the ideal preload must be determined based on the elastic total deformation δ_A (see chapter 12.5) and the deformation of the connecting structure.

When setting an R-guideway with **cage type EE**, the cage must first be slightly compressed before the rollers are applied.

As mentioned above, the preload increases the rigidity of the guideway. A high preload, however, requires a stable connecting structure. Otherwise unwanted edge loads occur to rollers and needles as a result of angular errors, which in turn has a negative impact on load carrying capacity.

Procedure for linear guideways

A guideway is normally set with zero-backlash using **adjusting screws**. A zero-backlash, uniform sequence is only achieved when advancing exclusively takes place where the cage with the rolling elements is located (see also chapter 13.9).

At least one **adjusting screw** must be provided per **fastening screw**, the thread size of which should match the **fastening screw**. In the case of **overrunning cages**, the shorter rail should preferably be advanced.

Example calculation for the infeed force per adjusting screw (Pvs) of their tightening torque (Mds)

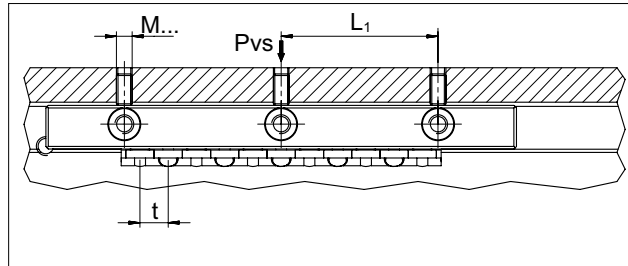

Required information per calculation:

- Linear guide type R 3 L₁ = 25 mm
- Roller cage type AC 3 t = 5 mm
- Diameter of the adjusting screw C = 130 N
- Factor f (for rollers = 1; for balls / needles = 2) = M4
- Preload p (2 % to 20 % of C) f = 1
- Factor a in cm (as per the following table) p = 10 %

| Thread | Factor a |
|--------|----------|
| M2 | 0.0238 |
| M2.5 | 0.0294 |
| M3 | 0.035 |
| M4 | 0.0469 |
| M5 | 0.058 |
| M6 | 0.0699 |
| M8 | 0.0926 |
| M10 | 0.1152 |
| M12 | 0.1378 |
| M14 | 0.1591 |
| M16 | 0.1811 |

Calculation of the infeed force per adjusting screw Pvs

$$P_{vs} = L_1 / t \cdot C \cdot p / 100 \cdot f$$

$$= 25 / 5 \cdot 130 \cdot 10 / 100 \cdot 1 = 65 \text{ N}$$

Calculation of tightening torque Mds

$$M_{ds} = P_{vs} \cdot a$$

$$= 65 \cdot 0.0469 = 3.05 \text{ Ncm}$$

Other technical possibilities for preloading linear guideways include:

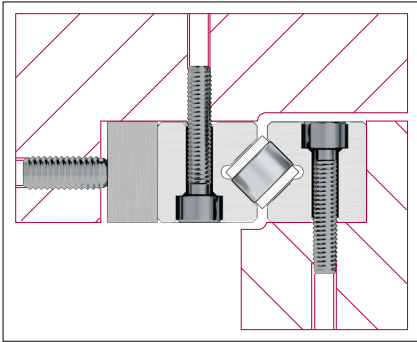

Setting using an **adjusting strip**

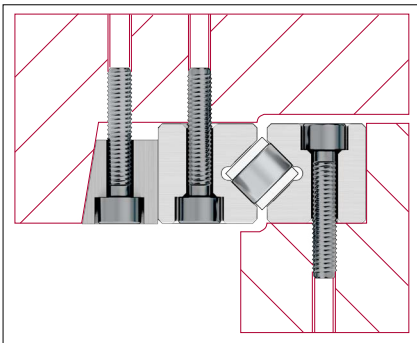

Setting using a **wedge adjuster**

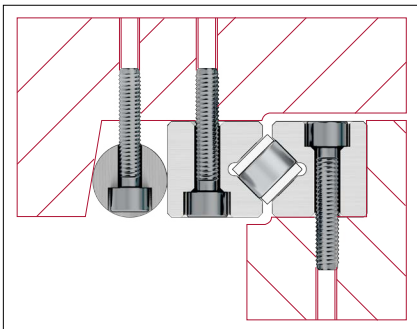

Setting using a **cylinder adjuster**

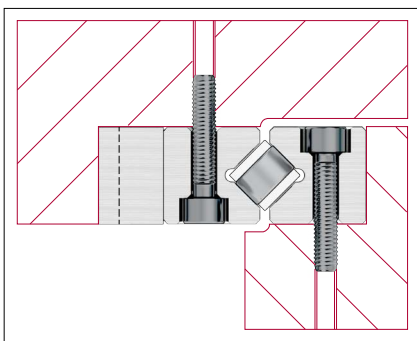

Setting using a **longitudinal wedge**

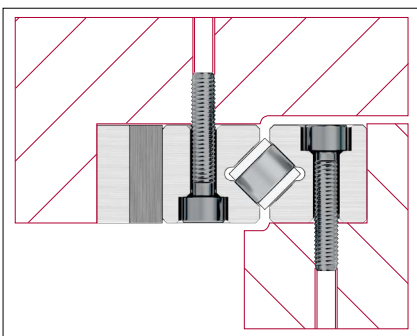

Setting using a **double longitudinal wedge**

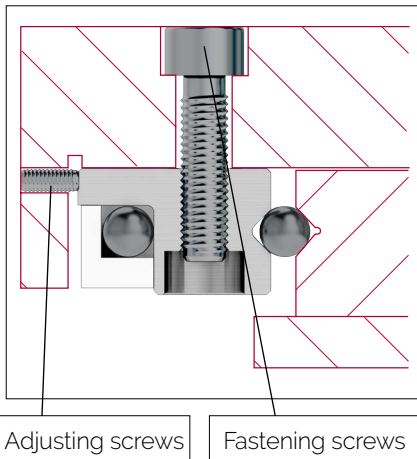

Procedure when preloading recirculating units (SK, SKD, SKC and SR)

A recirculating unit is normally set with zero-backlash using **adjusting screws**. At least one adjusting screw must be provided per **fastening screw**, the thread size of which should match the fastening screw.

Example calculation for the infeed force per adjusting screw (Pvs) of their tightening torque (Mds)

Required information per calculation:

- Recirculating unit SK 6-100 C = 715 N
- Diameter of the adjusting screw = M4
- Number of adjusting screws N = 2
- Factor f ("1" for roller, "2" for balls) = 2
- Preload p (5 % to 20 % of C) = 10%
- Factor a in cm as per the following table

| Thread | Factor a |
|--------|----------|
| M2 | 0.0238 |
| M2.5 | 0.0294 |
| M3 | 0.035 |
| M4 | 0.0469 |
| M5 | 0.058 |
| M6 | 0.0699 |
| M8 | 0.0926 |
| M10 | 0.1152 |
| M12 | 0.1378 |
| M14 | 0.1591 |
| M16 | 0.1811 |

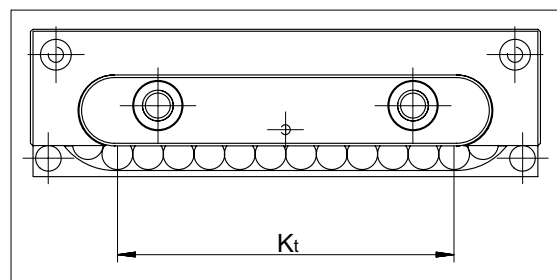

Calculation of the infeed force per adjusting screw Pvs

$$P_{vs} = C / N \cdot p / 100 \cdot f$$

$$= 715 / 2 \cdot 10 / 100 \cdot 2 = 71.5 \text{ N}$$

Calculation of tightening torque Mds

$$M_{ds} = P_{vs} \cdot a$$

$$= 71.5 \cdot 0.0469 = 3.35 \text{ Ncm}$$

Its advance must always remain within the load-bearing length K_t !

13 Construction and installation guidelines

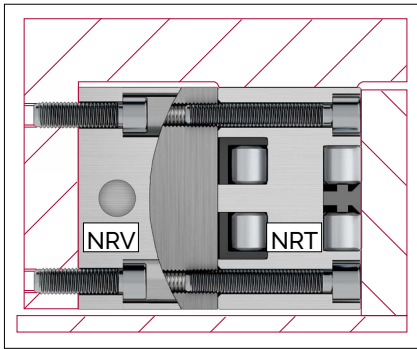

Procedure for recirculating unit NRT with preload wedge type NRV

For preload using preload wedge NRV the following infeed values apply:

| Type | Size | Max adjustment range in terms of height (mm) | Height difference per revolution of the preload screw A |
|------|-------|--|---|
| NRV | 19077 | 0.35 | 0.0350 |
| | 26111 | 0.40 | 0.0625 |
| | 26132 | 0.40 | 0.0625 |
| | 38144 | 0.40 | 0.0750 |

After successfully setting the preload, always tighten the two lock nuts alternately and use the wrench applying the same amount of torque!

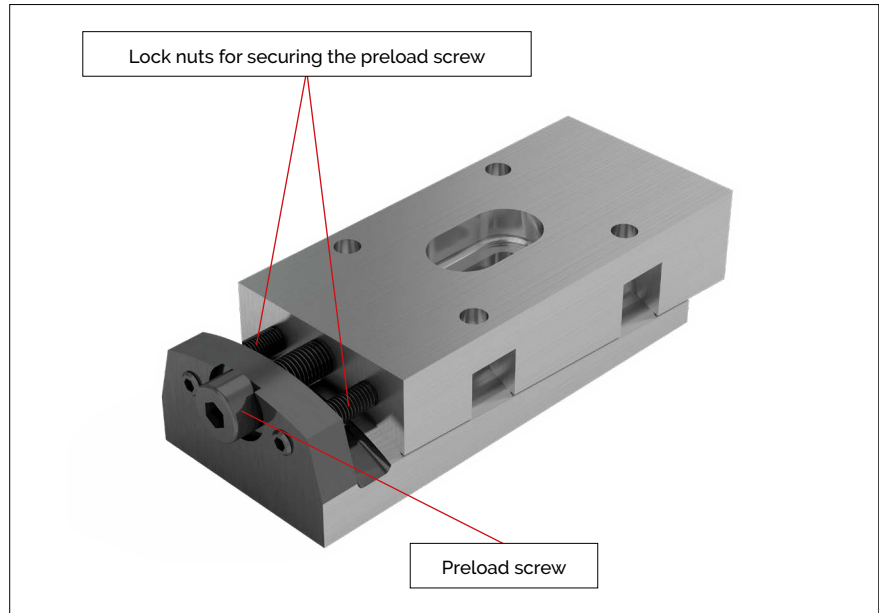

If preloading takes place without preload wedge NRV it is important to ensure that the advance must always remain within the load-bearing length K_t .

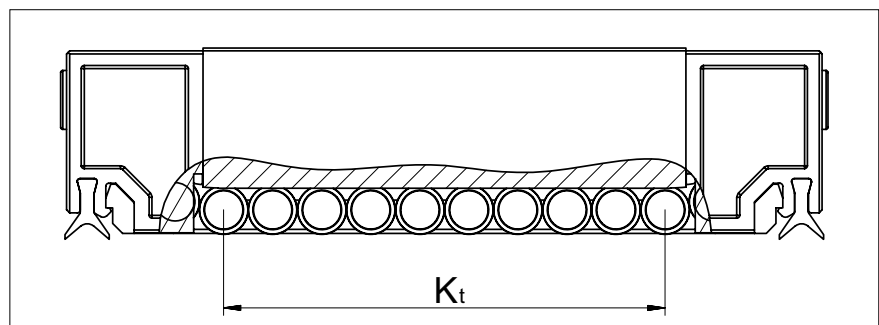

Other technical possibilities for preloading the NRT include:

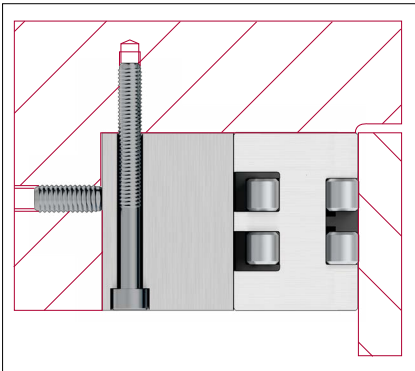

Setting using an intermediate plate

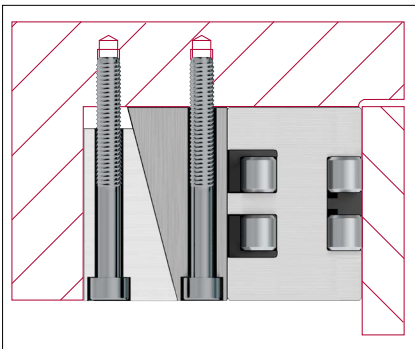

Setting using a wedge adjuster

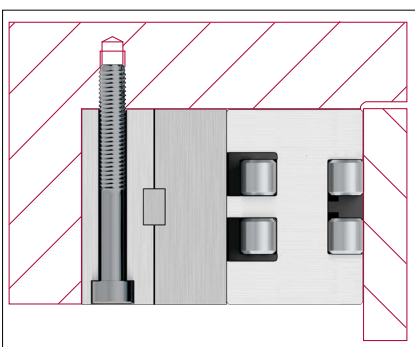

Setting using a double longitudinal wedge

13 Construction and installation guidelines

13.7 Sealing and covers

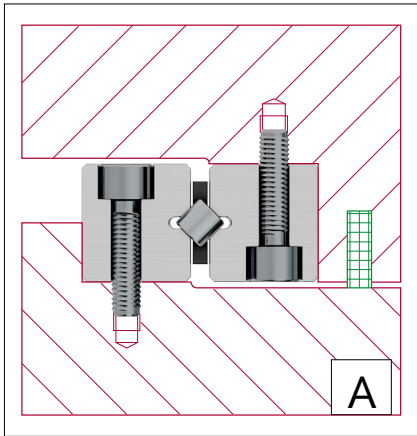

The method of sealing or covering is significant for the smooth operation and service life of the guideways.

Where there is only a small amount of dirt, wipers are sufficient to keep the tracks clean. Their braking effect can generally remain unattended. We offer a variety of standard wipers, which are described in detail in the respective product specifications.

Covers are used when there is some danger of harmful contamination of the guideway. While wipers only push the dirt off the running surfaces in the area of their movement, covers provide the opportunity of also keeping penetrating dirt away at the sides.

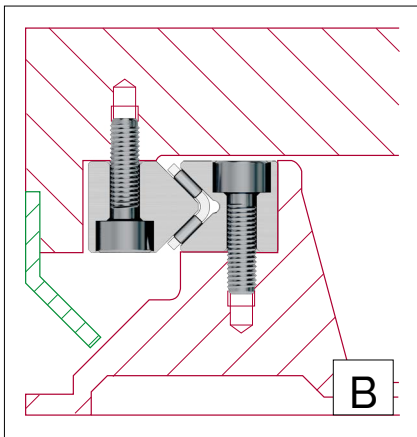

Some design options are listed below:

- A = Wiper sideways
- B = Diverting swarf and coolant away using a cover
- C = Labyrinth seals offer an effective and economically viable protection
- D = Simple metal cover
- E = Roll-up cover
- F = Bellows above or below
- G = Telescopic cover

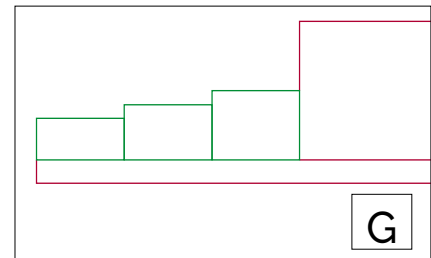
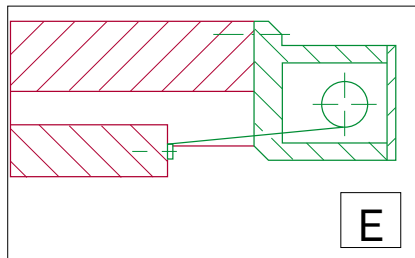
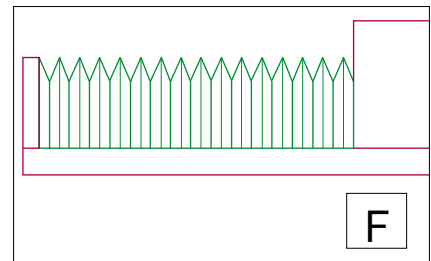
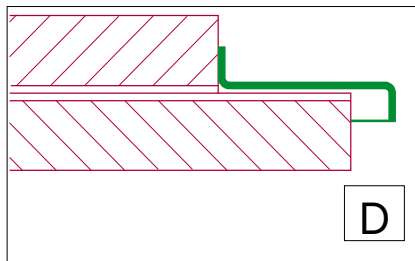
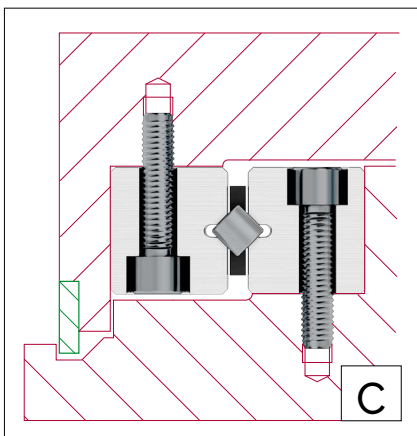

13.8 Lubrication

Lubrication is a design element and must therefore be defined during the development phase of a machine or application. If the lubrication is only selected after design and construction is complete, based on experience this is likely to lead to considerable difficulties. A carefully thought out lubrication concept is therefore a sign of a state-of-the-art and well devised design.

Parameters to be taken into account in selecting the lubricant, amongst others, include:

- Operating conditions (speed, accelerations, stroke, load, installation orientation)
- External influences (temperature, aggressive media or radiation, dirt accumulating, moisture)
- Subsequent lubrication (period of time, quantity, compatibility with other lubricants)
- Compatibility (with corrosion protection, with integrated materials such as plastic cages)
- Tracks (geometry, surface roughness, hardness, material, coating, wettability)

Technical and economic considerations determine the lubricant and process to be used. Generally lithium-soap-based roller bearing grease are used to lubricate (alloyed greases KP2K in accordance with DIN 51502 or DIN 51825). Oil dispensers or occasional oiling via oil nipples fully meet the demands of the guideways. For minimal roller frictional resistance lubrication with mineral-oil-based oils is recommended (CLP or HLP in viscosities of ISO VG 15 to 100 in accordance with DIN 51519).

The lubricants are normally applied through the spacing between the linear guideways and the recirculating units or through the lubrication holes in some instances available as standard or lube nipples in the recirculating units. If this is not supported by the design (e.g. in the case of vertical installation), on request linear guideways with lube holes can also be supplied. Particularly advantageous are oil mist lubrication methods, which help to prevent dirt accumulating on the guideways with their slight excess pressure. Their acceptability is greatly limited, however, due to their environmental impact. Cutting-oils or water soluble coolants are to be kept away from the guideways, however, because they dilute or wash away the available lubricant. In addition, coolants tend to stick when drying out. Lubricants with solid additives are inappropriate.

Subsequent lubrication intervals depend on the aforementioned operating conditions and external influences and cannot be therefore be calculated. That is why the lubrication point must be observed over a lengthy period of time.

Values based on historical experience show that with normal use subsequent lubrication of up to 2 to 5 times is sufficient, spread over the calculated service life.

Lubrication of the recirculating unit NRT

There are three ways of lubricating the NRT

Variant A: Lube nipple on each end face

Variant B: Lube opening on the top

Variant C: Optional connection for a centralised lubricating system

Variant A: Lubrication by means of the lube nipple

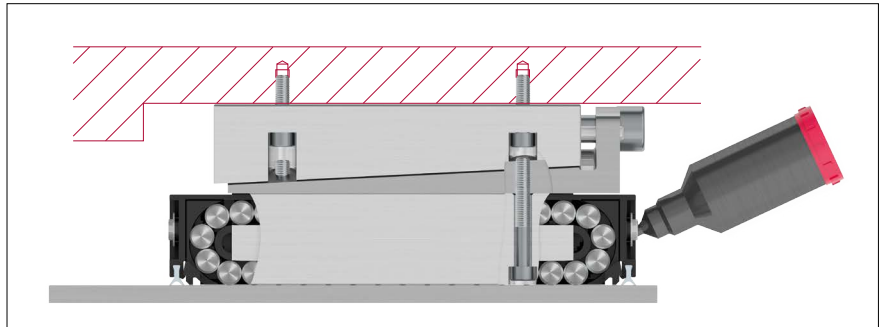

Variants B:

Oil delivery through the lube opening on the top

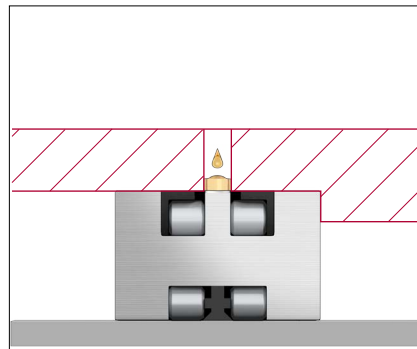

Oil delivery through the lube opening on the top through the preload wedge NRV

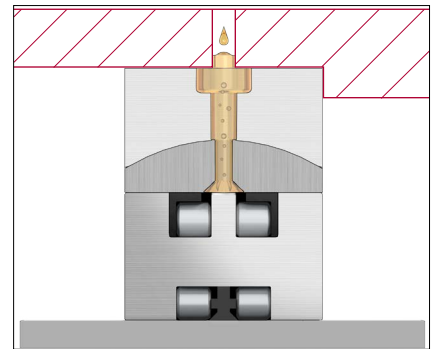

Variant C: Centralized lubricating system (option ZS)

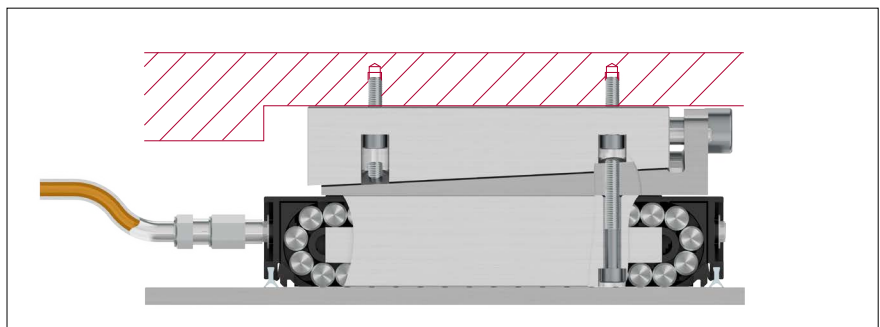

13 Construction and installation guidelines

13.9 Transport, handling and storage

Linear guideways and recirculating units are high-precision components and should therefore be handled with care. They should always be transported in their original packaging to protect them from damage and be stored at room temperature and in a dry environment.

Improper handling of the guideways can lead to preliminary damage and thus to premature failure. That is why their assembly may only be undertaken by expert professional staff.

13.10 Installation guidelines

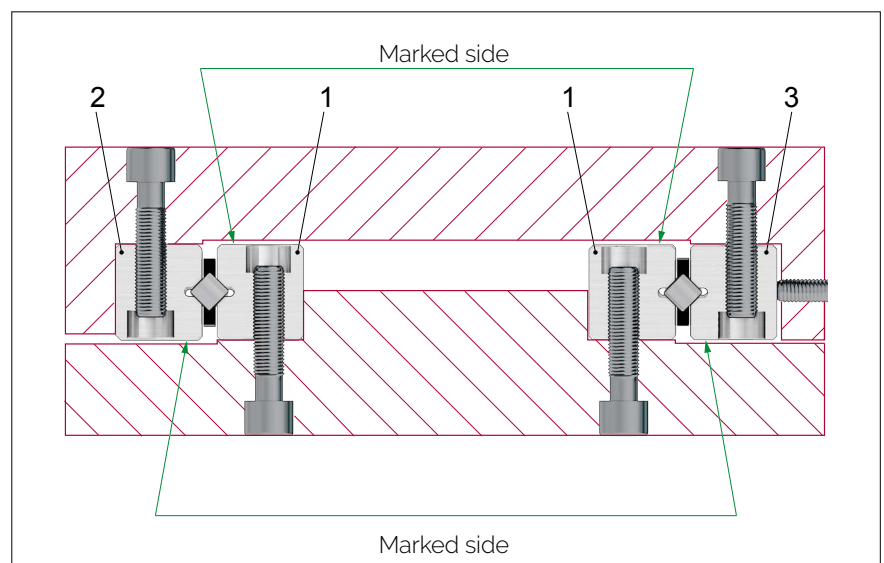

Linear guideways

With careful, clean preparation and a step by step approach, by adopting a rational procedure you will achieve a perfect guide system.

The following installation instructions applies by analogy for all types of SCHNEEBERGER linear guideways.

- To guarantee a perfect support for the guide rails, any remaining burrs or ridges are to be removed with a fine whetstone
- Before installation, the linear guideways and supporting surfaced should be cleaned. By means of a subsequent light lubrication they will be protected from any consequential damage

Tip for long or multi-part guide rails:

Due to the bore hole tolerances of the rails, the fastening holes in the supporting surfaces should be drilled according to the holes in the linear guideways. By using fastening screws with a thin shaft differences in hole spacings can also be evened out (see chapter 5).

- The marked side of the guide rail may not be used as a supporting surface!

- The fixed pair of linear guideways (1) is pressed against the supports using an appropriate clamping element and the fastening screws are tightened (use a torque wrench! For tightening torque see chapter 13.5.)

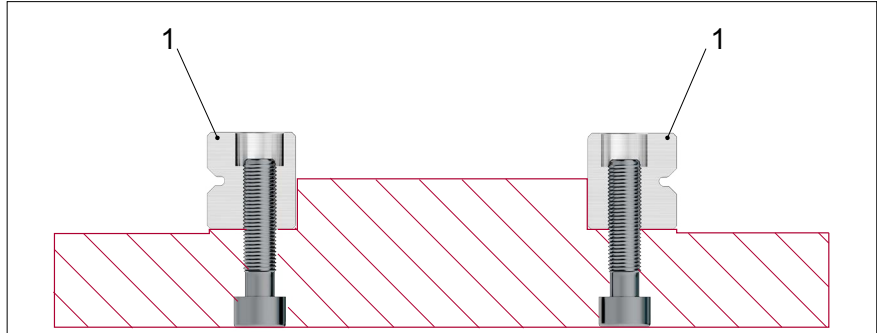

- Check parallelism ΔA and ΔP . The parallelisms measured must fall within the

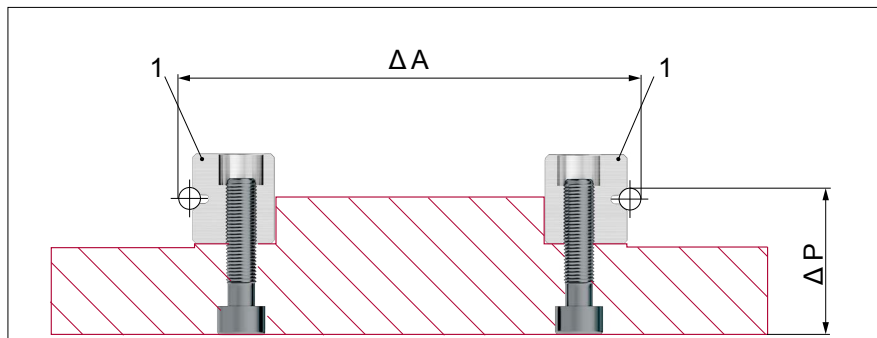

tolerances of the linear guideway (see chapter 7.1)

- Install the fixed rail (2) of the opposing pair

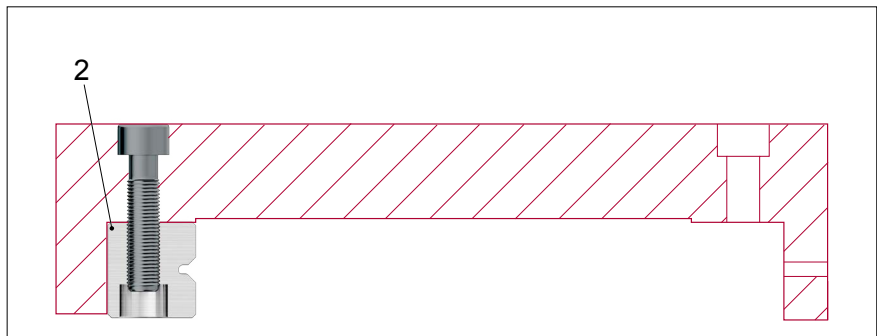

- Install the rail (3) and in so doing only lightly tighten the fastening screws
- Lubricating (see chapter 13.8)

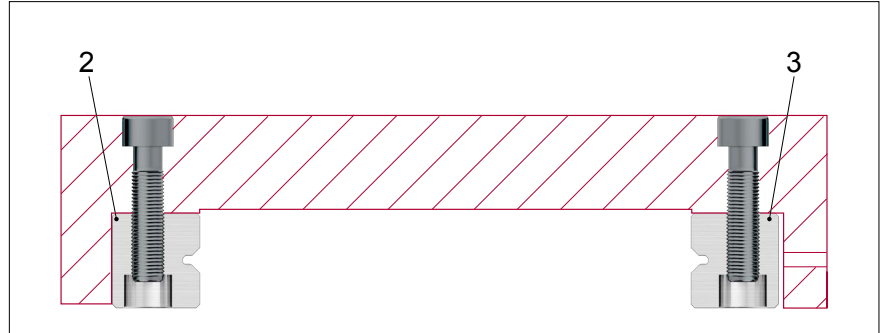

- Insert and center the cages (4). After that the linear bearings must be preloaded (please refer to the following page)

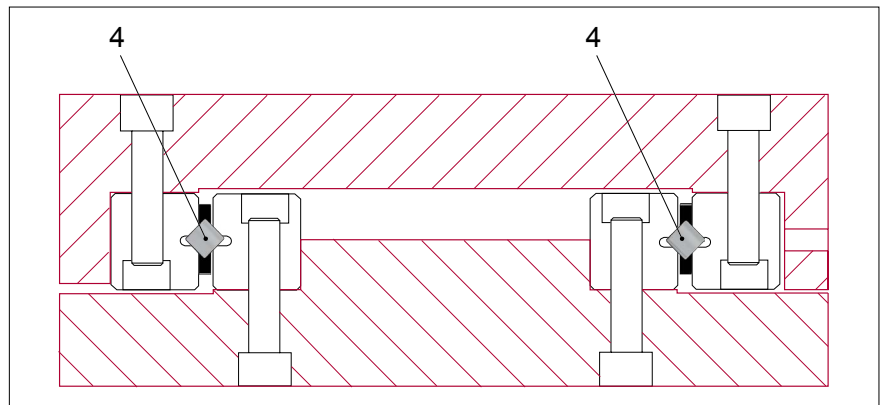

13 Construction and installation guidelines

- Set and/or preload the linear guideway with zero-backlash (see chapter 13.5)

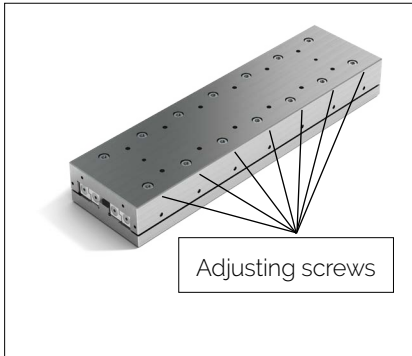

Application of the preload using the adjusting screws should be carried out from the centre of the rail outwards using the following steps (the sequence can be worked out from the figures):

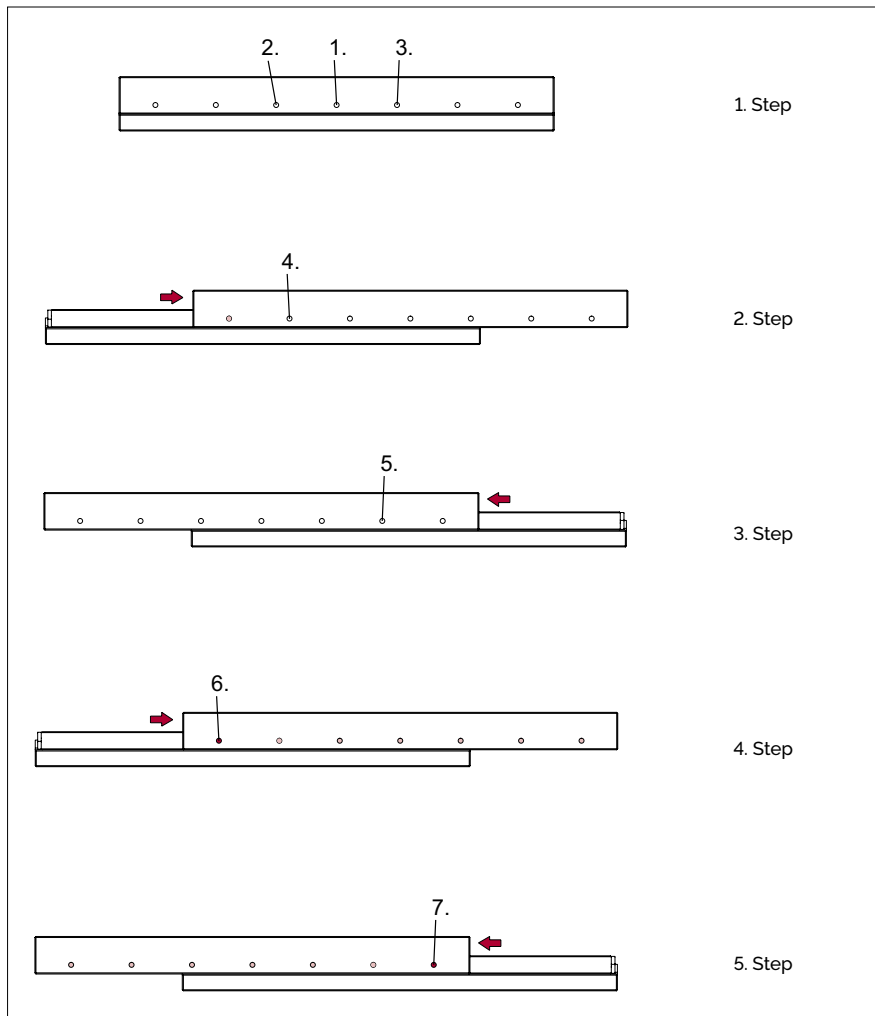

- Tighten the fastening screws for the rail (3)
- Install the end pieces

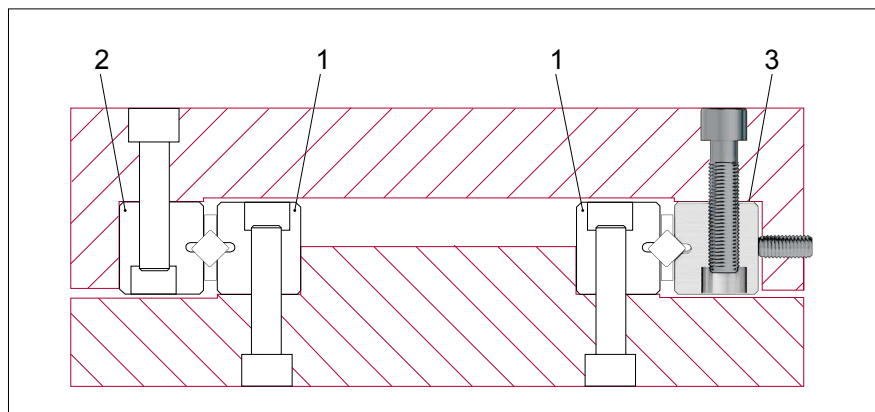

14 Order descriptions

Examples for linear guideways



| Example 1 - set consists of | Quantity | Type and size | Length in mm | Options |
|-----------------------------|----------|---------------|--------------|------------|
| Guide rails | 4 | RNG 6 | - 300 | -RF-SSQ-KS |
| Cage | 2 | KBS 6 x 20* | | -RF |

| Example 2 - set consists of | Quantity | Type and size | Length in mm | Options |
|-----------------------------|----------|---------------|--------------|---------|
| Guide rails | 2 | R 9 | - 800 | |
| Guide rails | 2 | R 9 | - 600 | -EG |
| Cage | 2 | AC 9 x 22* | | |
| End pieces | 8 | GC 9 | | |

* corresponds to the number of rolling elements
 Note: In the case of cage types HW and SHW the cage length must be indicated in mm!
 (e.g. SHW 20 x 155 mm)

Order example 1

Set RNG 6-300-RF-SSQ-KS; KBS 6x20-RF consisting of:
 - 4 pcs. Linear guide RNG 6-300-RF-SSQ-KS
 - Two pcs. Cage KBS 6x20-RF

Order example 2

Set R 9-800/600-EG; AC 9x22; GC 9 consisting of:
 - 2 pcs. Linear guides R 9-800
 - Two pcs. Linear Guide R 9-600-EG
 - Two pcs. Cage AC 9x22
 - 8 pcs. End piece GC 9

Example recirculating unit

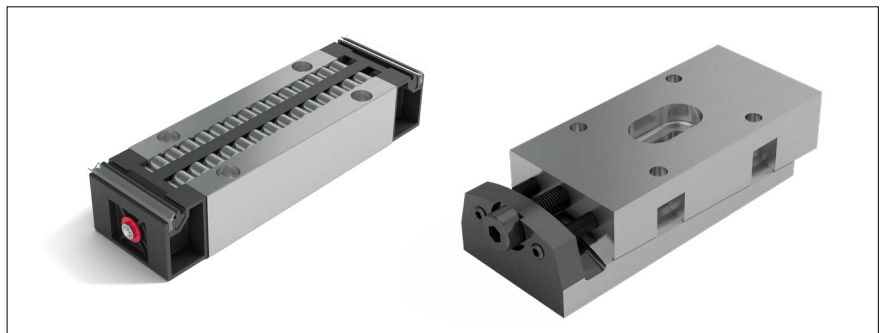

| | Quantity | Type and size | Options |
|---------------------|----------|---------------|---------|
| Recirculating units | 150 | NRT 26111 | -GP |
| Preload wedge | 150 | NRV 26111 | |

